

HCD-F3MD

SERVICE MANUAL

E Model

Self Diagnosis
Supported model



HCD-F3MD is the Amplifier, CD player, MD Deck and Tuner section in CMT-F3MD.

US and foreign patents licensed from Dolby Laboratories.

CD Section	Model Name Using Similar Mechanism	HCD-MD373
	CD Mechanism Type	CDM55A-5SBD32
	Base Unit Name	BU-5SBD32
MD Section	Optical Pick-up Name	KSS-213BH/Z-NP
	Model Name Using Similar Mechanism	HCD-MD373
	MD Mechanism Type	MDM-5GA
	Base Unit Name	MBU-5A
	Optical Pick-up Name	KMS-260B/S1NP

SPECIFICATIONS

Amplifier section

DIN power output (Rated): 20 + 20 watts (6 ohms at 1 kHz, DIN, 240 V)
18 + 18 watts (6 ohms at 1 kHz, DIN, 220 V)

Continuous RMS power output (Reference):
25 + 25 watts (6 ohms at 1 kHz, 10% THD, 240 V)
23 + 23 watts (6 ohms at 1 kHz, 10% THD, 220 V)

Peak Music Power Output: 400 watts

Inputs

TAPE IN (phono jacks): voltage 250 mV, impedance 47 kilohms

Outputs

TAPE OUT (phono jacks): voltage 250 mV, impedance 1 kilohm

PHONES (stereo minijack):

accepts headphones of 8 ohms or more.

SPEAKER:

accepts impedance of 6 to 16 ohms.

CD player section

System Compact disc and digital audio system

Laser Semiconductor laser ($\lambda=780$ nm)
Emission duration: continuous

Laser output

Max. 44.6 μ W*

*This output is the value measured at a distance of 200 mm from the objective lens surface on the Optical Pick-up Block with a 7 mm aperture.

Frequency response

2 Hz – 20 kHz

MD deck section

System MiniDisc digital audio system
Laser Semiconductor laser ($\lambda=780$ nm)
Emission duration: continuous

Laser output

Max. 44.6 μ W*

*This output is the value measured at a distance of 200 mm from the objective lens surface on the Optical Pick-up Block with a 7 mm aperture.

Sampling frequency

44.1 kHz

Frequency response

5 Hz – 20 kHz

Tuner section

FM stereo, FM/AM superheterodyne tuner

FM tuner section

Tuning range 87.5 – 108.0 MHz
(50 kHz step)

Aerial

FM lead aerial

Aerial terminals

75 ohms unbalanced

Intermediate frequency

10.7 MHz

AM tuner section

Tuning range 531 – 1,602 kHz
(with the interval set at 9 kHz)
530 – 1,710 kHz
(with the interval set at 10 kHz)

Aerial

AM loop aerial
External aerial terminals

Intermediate frequency

450 kHz

General

Power requirements 110 – 120 V or 220 – 240 V
AC, 50/60 Hz

Power consumption 70 watts during normal operation
Approx. 3 watts in standby mode (clock displayed)
Approx. 1 watt in standby mode (clock not displayed)

Dimensions (w/h/d) incl. projecting parts and controls
Approx. 215 × 150 × 335 mm

Mass

Approx. 4.9 kg

Design and specifications are subject to change without notice.

COMPACT DISC DECK RECEIVER

SONY®

SELF-DIAGNOSIS FUNCTION

The self-diagnosis function consists of error codes for customers, which are displayed automatically when errors occur, and error codes, which show the error history in the test mode during servicing. For details on how to view error codes for the customer, refer to the following box in the instruction manual. For details on how to check error codes during servicing, refer to the following “Procedure for using the Self-Diagnosis Function (Error History Display Mode)”.

Self-diagnosis Display

This system has a Self-diagnosis display function to let you know if there is a system malfunction. The display shows a code made up of three letters and a message alternately to show you the problem. To solve the problem refer to the following list. If any problem persists, consult your nearest Sony dealer.

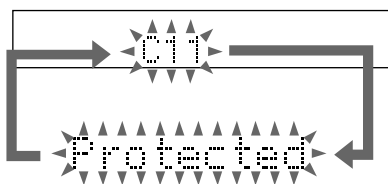

C11/Protected

The MD is protected against erasure.

→Remove the MD and slide the tab to close the slot (see page 24).

C12/Cannot Copy

You tried to record a CD or MD with a format that the system does not support, such as a CD-ROM.

→Remove the disc and turn off the system once, then turn it on again.

C13/REC Error

Recording could not be performed properly.

→Move the system to a stable place, and start recording over from the beginning.

The MD is dirty or scratched, or the MD does not meet the standards.

→Replace the MD and start recording over from the beginning.

C13/Read Error

The MD deck cannot read the disc information properly.

→Remove the MD once, then insert it again.

C14/Toc Error

The MD deck cannot read the disc information properly.

→Replace the MD.

→Erase all the recorded contents of the MD using the All Erase function on page 38.

C41/Cannot Copy

The sound source is a copy of a commercially available music software, or you tried to record a CD-R (Recordable CD).

→The Serial Copy Management System prevents making a digital copy (see page 53). You cannot record a CD-R.

PROCEDURE FOR USING THE SELF-DIAGNOSIS FUNCTION (ERROR HISTORY DISPLAY MODE)

Note 1: About “R”

As this unit has only a few buttons, some operations require the use of remote commander (RM-SF3MD/provided with unit: 1-476-068-11) buttons. These operations are indicated as “R” in this manual.

Example: **MENU/NO “R”** ...Press the **MENU/NO** button of the remote commander.

Note 2: Incorrect operations may be performed if the MD test mode is not entered properly.

In this case, press the **I/O** button to turn the power off, and retry to enter the MD test mode.

Note 3: Perform the self-diagnosis function in the “error history display mode” in the MD test mode. The following describes the least required procedure. Be careful not to enter other modes by mistake. If you set other modes accidentally, press the **MENU/NO “R”** button to exit the mode.

Procedure:

1. Press the **I/O** button to turn the power on.
2. Press the **FUNCTION** button to set the MD function.
3. Press three buttons of **MD**, **REC** and **I/O** simultaneously to enter the MD test mode and display “[Check]”.
4. Press the **LEFT** or **RIGHT** button to display “[Service]”, and press the **ENTER/YES “R”** button.
5. Press the **LEFT** or **RIGHT** button to display “ERR DP MODE”.
6. Press the **ENTER/YES “R”** button to enter the error history mode and display “total rec”.
7. Select the contents to be displayed or executed using the **LEFT** or **RIGHT** button.
8. Press the **CD-MD SYNC** button will display or execute the contents selected.
9. Press the **CD-MD SYNC** button another time returns to step 7.
10. Press the **MENU/NO “R”** button displays “ERR DP MODE” and release the error history mode.
11. To release the MD test mode, press the **REPEAT** button to display “Initialize” and release the MD test mode.

ITEMS OF ERROR HISTORY MODE ITEMS AND CONTENTS

Selecting the Test Mode



Display	Details of History
total rec	Displays the recording time. Displayed as "r□□□□□h". The displayed time is the total time the laser is set to the high power state. This is about 1/4 of the actual recording time. The time is displayed in decimal digits from 0h to 65535h.
total play	Displays the play time. Displayed as "p□□□□□h". The time displayed is the total actual play time. Pauses are not counted. The time is displayed in decimal digits from 0h to 65535h.
retry err	Displays the total number of retries during recording and number of retry errors during play. Displayed as "r□□ p□□". "r" indicates the retries during recording while "p" indicates the retry errors during play. The number of retries and retry errors are displayed in hexadecimal digits from 00 to FF.
total err	Displays the total number of errors. Displayed as "total □□". The number of errors is displayed in hexadecimal digits from 00 to FF.
err history	Displays the 10 latest errors. Displayed as "0□ E@@". □ indicates the history number. The smaller the number, the more recent is the error. (00 is the latest). @@ indicates the error code. Refer to the following table for the details. The error history can be switched by pressing the  or  button.
er refresh	Mode which erases the "retry err", "total err", and "err history" histories. When returning the unit to the customer after completing repairs, perform this to erase the past error history. After pressing the [CD-MD SYNC] button and "er refresh?" is displayed, press the [ENTER/YES "R"] button to erase the history. "Complete!" will be displayed momentarily. Be sure to check the following when this mode has been executed. <ul style="list-style-type: none"> • The data has been erased. • The mechanism operates normally when recording and play are performed.
tm refresh	Mode which erases the "total rec" and "total play" histories. These histories serve as approximate indications of when to replace the optical pick-up. If the optical pickup has been replaced, perform this operation and erase the history. After pressing the [CD-MD SYNC] button and "tm refresh?" is displayed, press the [ENTER/YES "R"] button to erase the history. "Complete!" will be displayed momentarily. Be sure to check the following when this mode has been executed. <ul style="list-style-type: none"> • The data has been erased. • The mechanism operates normally when recording and play are performed.

Table of Error Codes

Error Code	Details of Error	Error Code	Details of Error
E00	No error	E05	FOK has deviated
E01	Disc error. PTOC cannot be read (DISC ejected)	E06	Cannot focus (Servo has deviated)
		E07	Recording retry
E02	Disc error. UTOC error (DISC not ejected)	E08	Recording retry error
		E09	Playback retry error (Access error)
E03	Loading error		
E04	Address cannot be read (Servo has deviated)	E0A	Playback retry error (C2 error)

TABLE OF CONTENTS

SELF-DIAGNOSIS FUNCTION	2
1. SERVICING NOTES	5
2. GENERAL	16
3. DISASSEMBLY	18
4. TEST MODE	26
5. ELECTRICAL ADJUSTMENTS	
MD Section	30
CD Section	38
6. DIAGRAMS	
6-1. Block Diagram – CD SERVO Section –	39
6-2. Block Diagram – MD SERVO Section (1/2) –	40
6-3. Block Diagram – MD SERVO Section (2/2) –	41
6-4. Block Diagram – MAIN Section –	42
6-5. Note for Printed Wiring Boards and Schematic Diagrams	43
6-6. Printed Wiring Board – BD (CD) Board –	44
6-7. Schematic Diagram – BD (CD) Board –	45
6-8. Schematic Diagram – BD (MD) Board (1/2) –	46
6-9. Schematic Diagram – BD (MD) Board (2/2) –	47
6-10. Printed Wiring Board – BD (MD) Board –	48
6-11. Schematic Diagram – BD SW (MD) Board –	49
6-12. Printed Wiring Board – BD SW (MD) Board –	49
6-13. Schematic Diagram – LOADING (CD) Board –	49
6-14. Printed Wiring Board – LOADING (CD) Board –	49
6-15. Printed Wiring Board – MD DIGITAL Board –	50
6-16. Schematic Diagram – MD DIGITAL Board –	51
6-17. Printed Wiring Board – MAIN Board –	52
6-18. Schematic Diagram – MAIN Board (1/3) –	53
6-19. Schematic Diagram – MAIN Board (2/3) –	54
6-20. Schematic Diagram – MAIN Board (3/3) –	55
6-21. Printed Wiring Boards – AMP/SP Boards –	56
6-22. Schematic Diagram – AMP/SP Boards –	57
6-23. Printed Wiring Board – PANEL Board –	58
6-24. Schematic Diagram – PANEL Board –	59
6-25. Printed Wiring Board – POWER Board –	60
6-26. Schematic Diagram – POWER Board –	61
6-27. IC Pin Function Description	70
7. EXPLODED VIEWS	80
8. ELECTRICAL PARTS LIST	86

Notes on chip component replacement

- Never reuse a disconnected chip component.
- Notice that the minus side of a tantalum capacitor may be damaged by heat.

Flexible Circuit Board Repairing

- Keep the temperature of the soldering iron around 270 °C during repairing.
- Do not touch the soldering iron on the same conductor of the circuit board (within 3 times).
- Be careful not to apply force on the conductor when soldering or unsoldering.

CAUTION

Use of controls or adjustments or performance of procedures other than those specified herein may result in hazardous radiation exposure.

This appliance is classified as a CLASS 1 LASER product. The CLASS 1 LASER PRODUCT MARKING is located on the rear exterior.

CLASS 1 LASER PRODUCT
LUOKAN 1 LASERLAITE
KLASS 1 LASERAPPARAT

Laser component in this product is capable of emitting radiation exceeding the limit for Class 1.

The following caution label is located inside the unit.

CAUTION : INVISIBLE LASER RADIATION WHEN OPEN AND INTERLOCKS DEFEATED. AVOID EXPOSURE TO BEAM.
ADVARSEL : USYNLIG LASERSTRÅLING VED ÅBNING NÅR SIKKERHEDSAFBRYDERE ER UDE AF FUNKTION. UNDGÅ UDSÆTTELSE FOR STRÅLING.
VORSICHT : UNSICHTBARE LASERSTRAHLUNG, WENN ABDECKUNG GEÖFFNET UND SICHERHEITSVERRIEGELUNG ÜBERBRÜCKT. NICHT DEM STRAHL AUSSETZEN.
VARO! : AVATTAESSA JA SUJALUKITUS OHITETTAESSA OLET ALTIINIINÄ NÄKYMÄTTÖMÄLLE LASERSÄTEILYLLE. ÄLÄ KATSO SÄTEESEEN.
WARNING : OSYNLIG LASERSTRÅLING NÅR DENNA DEL ÅR ÖPPNAD OCH SPÅRREN ÅR URKOPPLAD, BETRAKTA EJ STRÅLEN.
ADVERSEL : USYNLIG LASERSTRÅLING NÅR DEKSEL ÅPNES OG SIKKERHEDSLÅS BRYTES. UNNGÅ EKSPONERING FOR STRÅLEN.
VIGYAZAT! : A BURKOLAT NYITÁSAKOR LÁTHATATLAN LÉZERSUGÁRVESZÉLY! KERÜLJE A BESUGÁRZÁST!

SAFETY-RELATED COMPONENT WARNING!!

COMPONENTS IDENTIFIED BY MARK \triangle OR DOTTED LINE WITH MARK \triangle ON THE SCHEMATIC DIAGRAMS AND IN THE PARTS LIST ARE CRITICAL TO SAFE OPERATION. REPLACE THESE COMPONENTS WITH SONY PARTS WHOSE PART NUMBERS APPEAR AS SHOWN IN THIS MANUAL OR IN SUPPLEMENTS PUBLISHED BY SONY.

SECTION 1 SERVICING NOTES

NOTES ON HANDLING THE OPTICAL PICK-UP BLOCK OR BASE UNIT

The laser diode in the optical pick-up block may suffer electrostatic break-down because of the potential difference generated by the charged electrostatic load, etc. on clothing and the human body.

During repair, pay attention to electrostatic break-down and also use the procedure in the printed matter which is included in the repair parts.

The flexible board is easily damaged and should be handled with care.

For CD

NOTES ON LASER DIODE EMISSION CHECK

The laser beam on this model is concentrated so as to be focused on the disc reflective surface by the objective lens in the optical pick-up block. Therefore, when checking the laser diode emission, observe from more than 30 cm away from the objective lens.

LASER DIODE AND FOCUS SEARCH OPERATION CHECK

Carry out the "S curve check" in "CD section adjustment" and check that the S curve waveforms is output three times.

For MD

NOTES ON LASER DIODE EMISSION CHECK

Never look into the laser diode emission from right above when checking it for adjustment. It is feared that you will lose your sight.

CLEANING OBJECTIVE LENS OF OPTICAL PICK-UP

- In cleaning the objective lens of optical pick-up, be sure the following below.
1. In cleaning the lens, do not apply an excessive force.
As the optical pick-up is vulnerable, application of excessive force could damage the lens holder.
 2. In cleaning, do not use a cleaner other than exclusive cleaning liquid (KK-91 or isopropyl alcohol).
 3. Wipe the objective lens spirally from center toward outside.
(See Figure A)

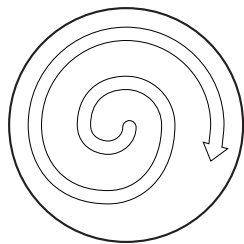

(Figure A)

4. Eject the disk, if loaded.
5. Disconnect the power cord from the socket to shut off the power supply.
6. When cleaning the objective lens of optical pick-up in CD, refer to "HOLDER (BU) ASS'Y" on page 24 for removing HOLDER (BU) ASS'Y.

MODEL IDENTIFICATION

— Back panel —

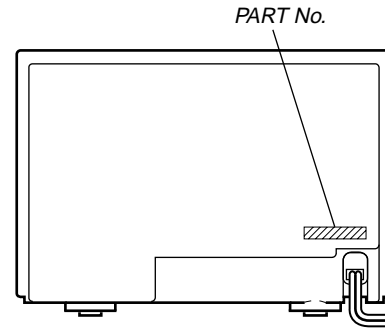

Model	Part No.
Hong Kong model	4-229-548-1□
Korean model	4-232-128-0□
Taiwan model	4-232-129-0□

DRAWING OUT THE TRAY WHEN THE POWER IS OFF

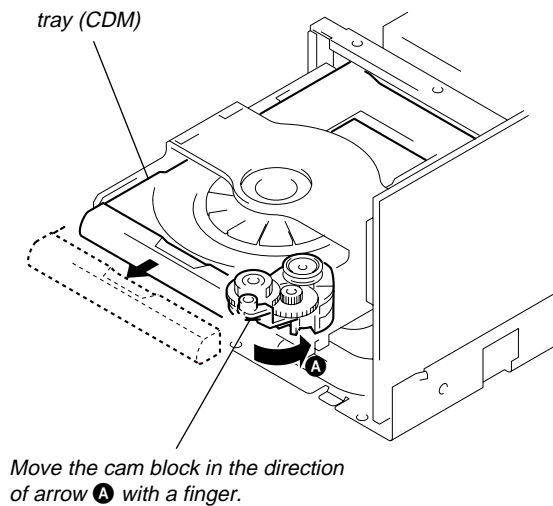

CLEANING THE OPTICAL PICK-UP (CD PLAYER)

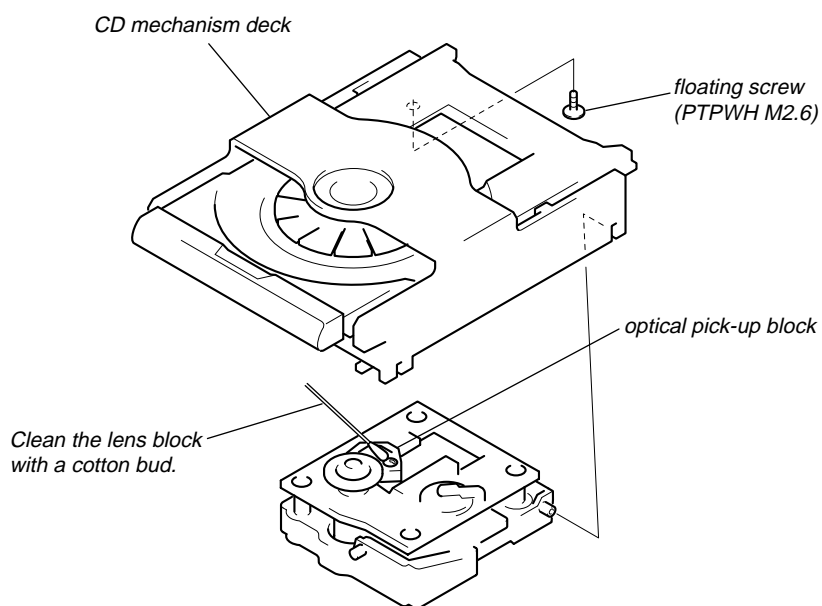

SERVICE POSITION OF THE MD MECHANISM DECK

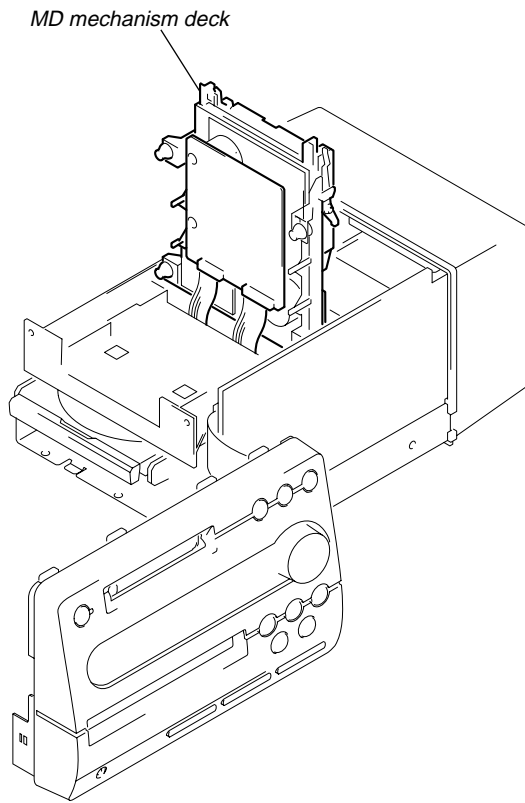

SERVICE POSITION OF THE CD MECHANISM DECK

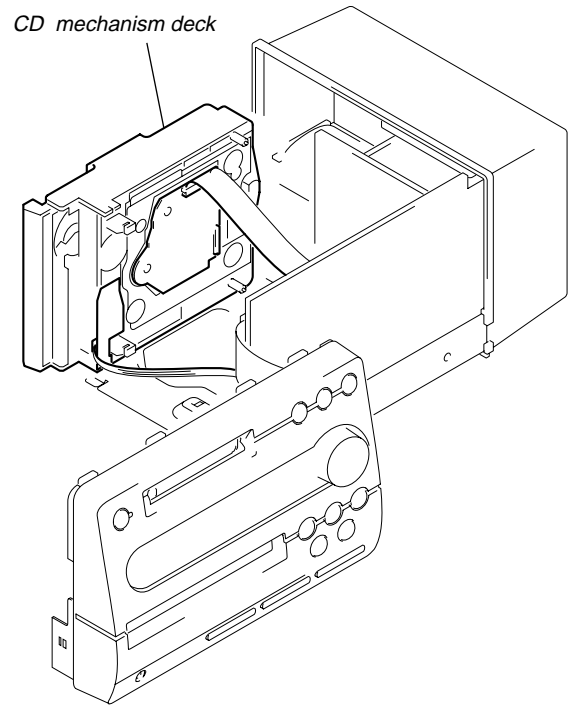



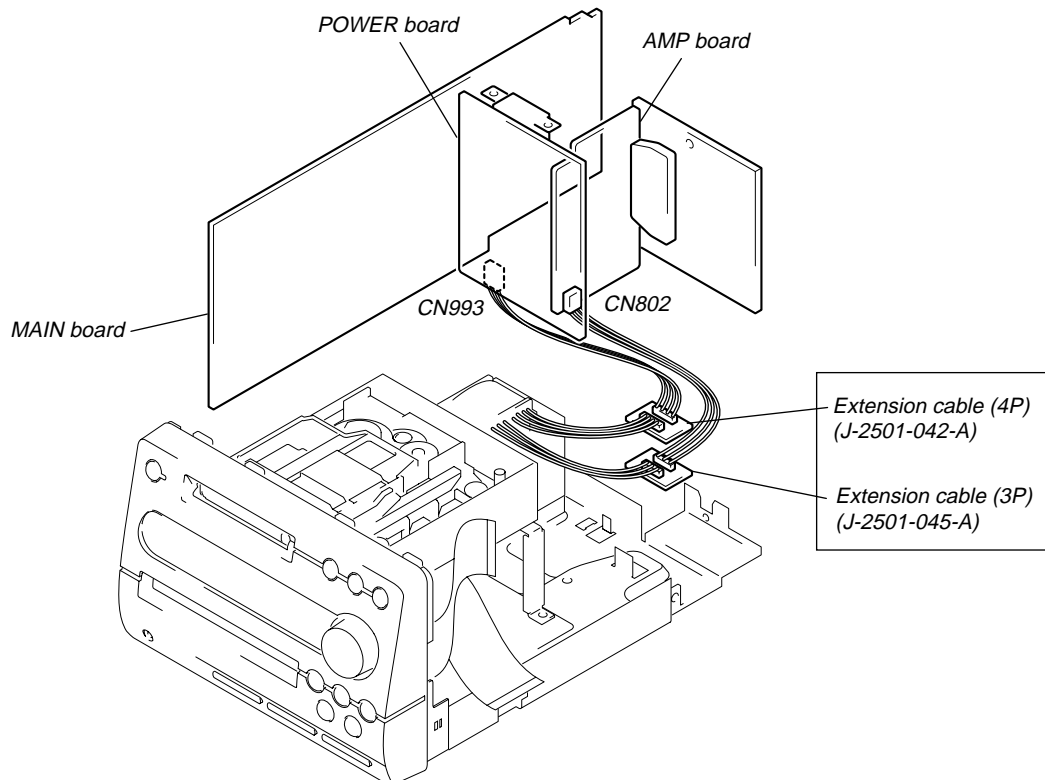

SERVICE POSITION OF THE POWER BOARD



MC COLD RESET

- The cold reset clears all data including preset data stored in the RAM to initial conditions. Execute this mode when returning the set to the customer.





Procedure:

1. Press the  button to turn the power on.
2. While pressing the  and  (CD) buttons, press the  button.
3. The set is reset, and displays “COLD RESET”, then becomes standby status.

MC HOT RESET





- This mode resets the set with the preset data kept stored in the memory. The hot reset mode function is same as if the power cord is plugged in and out.



Procedure:

1. Press the  button to turn the power on.
2. While pressing the  and  (CD) buttons, press the  button.
3. The set is reset, and becomes standby state.

LED/FLUORESCENT INDICATOR TUBE AND KEY TEST

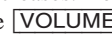
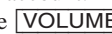
Procedure:







1. Press the  button to turn the power on.
2. While pressing the  and  (CD) buttons, press the  button.
3. LEDs and fluorescent indicator tube are all turned on.
4. Press the  (MD) button to enter the key test mode, and display “Key0 Vol0”.
5. Each time a button is pressed, “Key” value increases. However, once a button is pressed, it is no longer taken into account. “Vol” value increases like 0, 1, 2 ... if turn the  knob clockwise, or it decreases like 9, 8, 7 ... if turn the  knob counterclockwise.
6. To release from this mode, press three buttons in the same manner as step 2, or disconnect the power cord.

Note:  and  buttons are no longer taken into account, if it pressed within for a second.

CHANGE-OVER THE AM TUNING INTERVAL

- The AM tuning interval can be changed over 9 kHz or 10 kHz.

Procedure:

1. Press the  button to turn the power on.
2. Press the  button to set the TUNER function, and press the  button to select the band “AM”.
3. Press the  button to turn the power off.
4. When the power off, press the  button while pressing the  button, and the display of fluorescent indicator tube changes to “AM 9k STEP” or “AM 10k STEP”, and thus the tuning interval is changed over.

MD SECTION

JIG FOR CHECKING BD (MD) BOARD WAVEFORM

The special jig (J-2501-149-A) is useful for checking the waveform of the BD (MD) board. The names of terminals and the checking items to be performed are shown as follows.

GND : Ground

I+3V : For measuring IOP (Check the deterioration of the optical pick-up laser)

IOP : For measuring IOP (Check the deterioration of the optical pick-up laser)

TEO : Tracking error signal (Traverse adjustment)

VC : Reference level for checking the signal

RF : RF signal (Check jitter)

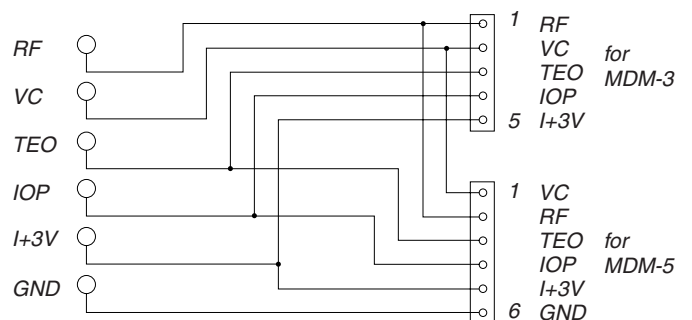
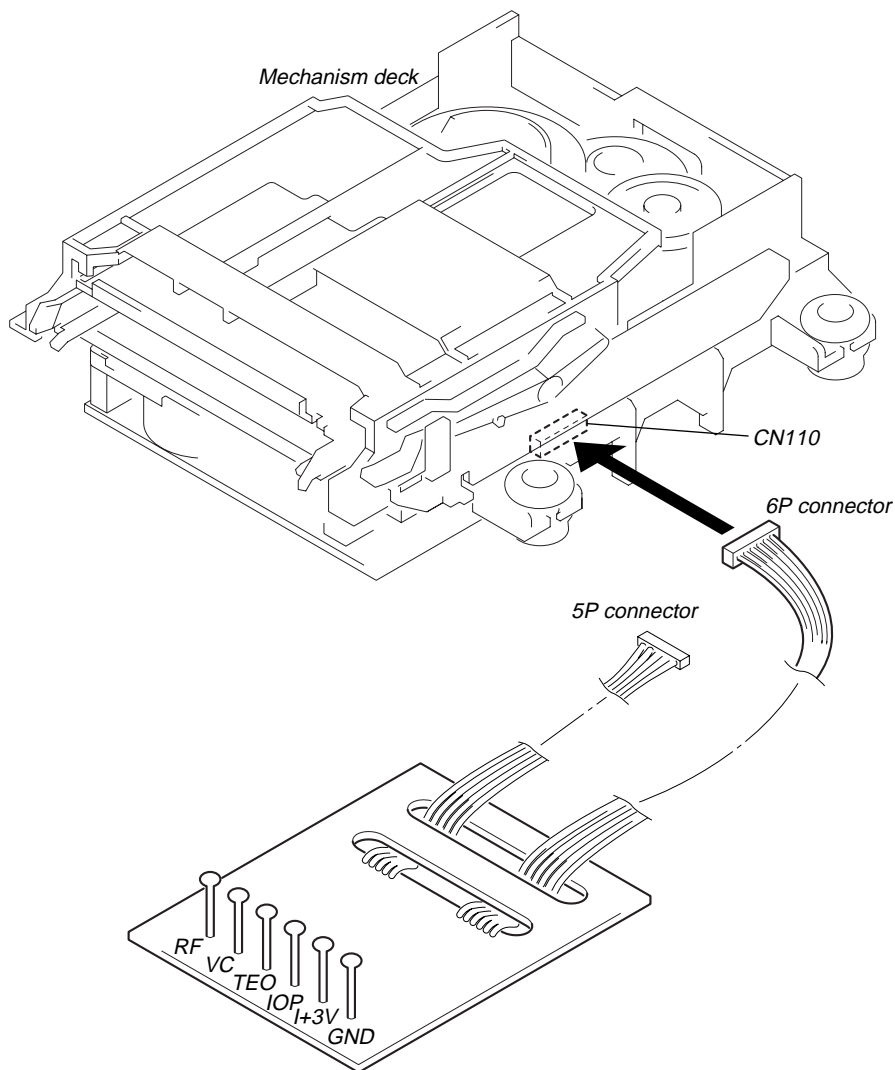

Note : About “R”

As this unit has only a few buttons, some operations require the use of remote commander (RM-SF3MD/provided with unit: 1-476-068-11) buttons. These operations are indicated as “R” in this manual.

Example: **MENU/NO “R”** ...Press the **MENU/NO** button of the remote commander.

IOP DATA RECORDING AND DISPLAY WHEN OPTICAL PICK-UP AND NON-VOLATILE MEMORY (IC171 ON THE BD (MD) BOARD) ARE REPLACED

The IOP value labeled on the optical pick-up can be recorded in the non-volatile memory. By recording the value, it will eliminate the need to look at the value on the label of the optical pick-up. When replacing the optical pick-up or non-volatile memory (IC171 on the BD (MD) board), record the IOP value on the optical pick-up according to the following procedure.

Record Procedure:

1. Press the **I/O** button to turn the power on.
2. Press the **FUNCTION** button to set the MD function.
3. While pressing the **MD** and **●REC** buttons, press the **I/O** button to enter the MD test mode and display “[Check]”.
4. Press the **◀◀** or **▶▶** button to display “[Service]”, and press the **ENTER/YES “R”** button.
5. Press the **◀◀** or **▶▶** button to display “Iop Write”, and press the **ENTER/YES “R”** button.
6. The display becomes “Ref=@@.@” (@ is an arbitrary number) and the numbers which can be changed will blink.
To select the number : Press the **◀◀** or **▶▶** button.
To select the digit : Press the **SYNC REC** button.
8. When the **ENTER/YES “R”** button is pressed, the display becomes “Measu=@@.@” (@ is an arbitrary number).
9. As the adjustment results are recorded for the step7 value. Leave it as it is and press the **ENTER/YES “R”** button.
10. “Complete!” will be displayed momentarily. The value will be recorded in the non-volatile memory and the display will become “Iop Write”.
11. Press the **REPEAT** button to complete. “Standby” will be displayed.

Display Procedure:

1. Press the **I/O** button to turn the power on.
2. Press the **FUNCTION** button to set the MD function.
3. While pressing the **MD** and **●REC** buttons, press the **I/O** button to enter the MD test mode and display “[Check]”.
4. Press the **◀◀** or **▶▶** button to display “[Service]”, and press the **ENTER/YES “R”** button.
5. Press the **◀◀** or **▶▶** button to display “Iop Read”, and press the **ENTER/YES “R”** button.
6. “@@.@/##.#” is displayed and the recorded contents are displayed.
@@.@ : indicates the Iop value labeled on the pick-up.
##.# : indicates the Iop value after adjustment
7. To release, press the **CD-MD SYNC** button or **MENU/NO “R”** button to display “Iop Read”. Then press the **REPEAT** button to display “Standby”.

CHECKS PRIOR TO PARTS REPLACEMENT AND ADJUSTMENTS

Before performing repairs, perform the following checks to determine the faulty locations up to a certain extent. Details of the procedures are described in “5 Electrical Adjustments”.

	Criteria for Determination (Unsatisfactory if specified value is not satisfied)	Measure if unsatisfactory:
Laser power check (5-6-2 : See page 32)	<ul style="list-style-type: none"> 0.9 mW power Specified value : 0.84 to 0.92 mW 7.0 mW power Specified value : 6.8 to 7.2 mW 	<ul style="list-style-type: none"> Clean the optical pick-up Adjust again Replace the optical pick-up
	<ul style="list-style-type: none"> Iop (at 7mW) Labeled on the optical pickup Iop value \pm 10mA 	<ul style="list-style-type: none"> Replace the optical pick-up
Traverse check (5-6-3 : See page 32)	<ul style="list-style-type: none"> Traverse waveform Specified value : Below 10% offset 	<ul style="list-style-type: none"> Replace the optical pick-up
Focus bias check (5-6-4 : See page 33)	<ul style="list-style-type: none"> Error rate check Specified value : For points A, B C1 error : About 200 AD error : Below 2 For point C C1 error : Below 50 AD error : Below 2 	<ul style="list-style-type: none"> Replace the optical pick-up
C PLAY check (5-6-5 : See page 33)	<ul style="list-style-type: none"> Error rate check Specified value: <ol style="list-style-type: none"> When using test disc (MDW-74/AU-1) C1 error : Below 80 AD error : Below 2 When using check disc (TDYS-1) C1 error : Below 50 	<ul style="list-style-type: none"> Replace the optical pick-up
Self-recording/playback check (5-6-6 : See page 33)	<ul style="list-style-type: none"> CPLAY error rate check Specified value: C1 error : Below 80 AD error : Below 2 	If always unsatisfactory: <ul style="list-style-type: none"> Replace the overwrite head Check for disconnection of the circuits around the overwrite head
		If occasionally unsatisfactory: <ul style="list-style-type: none"> Check if the overwrite head is distorted Check the mechanism around the sled
Temperature compensation offset check (5-6-1 : See page 32)	<ul style="list-style-type: none"> Unsatisfactory if displayed as T=@@ (##) [NG” NG (@@, ## are both arbitrary numbers) 	<ul style="list-style-type: none"> Check for disconnection of the circuits around D101 (BD (MD) board) Check the signals around IC101, IC121, CN102, CN103 (BD (MD) board)

Note:

The criteria for determination above is intended merely to determine if satisfactory or not, and does not serve as the specified value for adjustments. When performing adjustments, use the specified values for adjustments.

RETRY CAUSE DISPLAY MODE

- In this test mode, the causes for retry of the unit during recording can be displayed on the fluorescent indicator tube. During playback, the “track mode” for obtaining track information will be set. This is useful for locating the faulty part of the unit.
- The following will be displayed :
 - During recording and stop : Retry cause, number of retries, and number of retry errors.
 - During playback : Information such as type of disc played, part played, copyright.
 These are displayed in hexadecimal.

Procedure:

- Load a recordable disc whose contents can be erased into the unit.
- Press the **MENU/NO “R”** button. When “Edit Menu” is displayed on the fluorescent indicator tube, press the **◀◀** or **▶▶** button to display “All Erase?”.
- Press the **ENTER/YES “R”** button.
- When “All Erase??” is displayed on the fluorescent indicator tube, the music calendar number blinks.
- Press the **ENTER/YES “R”** button to display “Complete!!”, and press the **□ (MD)** button immediately. Wait for about 10 seconds while pressing the button.
- When the “TOC” displayed on the fluorescent display tube goes off, release the **□ (MD)** button.
- Press the **●REC** button to start recording. Then press the **▶▶ (MD)** button and start recording. If recording cannot be performed, press the **FUNCTION** button and set a different function.
- To check the “track mode”, press the **▶▶ (MD)** button to start play.
- To release the test mode, press the **I/O** button, and turn the power off. When “TOC” disappears, disconnect the power plug from the outlet. If the test mode cannot be released, refer to “MC COLD RESET” on page 8).

Fig. 1 Reading the Test Mode Display (During recording and stop)

RTs@@c##e**

Fluorescent indicator tube display

@@ : Cause of retry
 ## : Number of retries
 ** : Number of retry errors

Fig. 2 Reading the Test Mode Display (During playback)

@@ ####** \$\$

Fluorescent indicator tube display

@@ : Parts No. (name of area named on TOC)
 ## : Cluster } Address
 ** : Sector }
 \$\$: Track mode (Track information such as copyright information of each part)

Reading the Retry Cause Display

Hexadecimal	Higher Bits				Lower Bits				Hexadecimal	Cause of Retry	Occurring conditions
	8	4	2	1	8	4	2	1			
Bit	b7	b6	b5	b4	b3	b2	b1	b0			
Binary	0	0	0	0	0	0	0	1	01	shock	When track jump (shock) is detected
	0	0	0	0	0	0	1	0	02	ader5	When ADER was counted more than five times continuously
	0	0	0	0	0	1	0	0	04	Discontinuous address	When ADIP address is not continuous
	0	0	0	0	1	0	0	0	08	DIN unlock	When DIN unlock is detected
	0	0	0	1	0	0	0	0	10	FCS incorrect	When not in focus
	0	0	1	0	0	0	0	0	20	IVR rec error	When ABCD signal level exceeds the specified range
	0	1	0	0	0	0	0	0	40	CLV unlock	When CLV is unlocked
	1	0	0	0	0	0	0	0	80	Access fault	When access operation is not performed normally

Reading the Display:

Convert the hexadecimal display into binary display. If more than two causes, they will be added.

Example

When 42 is displayed:

Higher bit: 4 = 0100 → b6

Lower bit : 2 = 0010 → b1

In this case, the retry cause is combined of “CLV unlock” and “ader5”.

When A2 is displayed:

Higher bit: A = 1010 → b7+b5

Lower bit : 2 = 0010 → b1

The retry cause in this case is combined of “access fault”, “IVR rec error”, and “ader5”.

Reading the Retry Cause Display

Hexadecimal	Higher Bits				Lower Bits				Hexa- decimal	Details	
	8	4	2	1	8	4	2	1		When 0	When 1
Bit	b7	b6	b5	b4	b3	b2	b1	b0			
Binary	0	0	0	0	0	0	0	1	01	Emphasis OFF	Emphasis ON
	0	0	0	0	0	0	1	0	02	Monaural	Stereo
	0	0	0	0	0	1	0	0	04	This is 2-bit display. Normally 01. 01:Normal audio. Others:Invalid	
	0	0	0	0	1	0	0	0	08		
	0	0	0	1	0	0	0	0	10	Audio (Normal)	Invalid
	0	0	1	0	0	0	0	0	20	Original	Digital copy
	0	1	0	0	0	0	0	0	40	Copyright	No copyright
	1	0	0	0	0	0	0	0	80	Write prohibited	Write allowed

Reading the Display:

Convert the hexadecimal display into binary display. If more than two causes, they will be added.

Example When 84 is displayed:

Higher bit: 8 = 1000 → b7

Lower bit : 4 = 0100 → b2

In this case, as b2 and b7 are 1 and others are 0, it can be determined that the retry cause is combined of “emphasis OFF”, “monaural”, “original”, “copyright exists”, and “write allowed”.

Example When 07 is displayed:

Higher bit: 0 = 0000 → All 0

Lower bit : 7 = 0111 → b0+b1+b2

In this case, as b0, b1, and b2 are 1 and others are 0, it can be determined that the retry cause is combined of “emphasis ON”, “stereo”, “original”, “copyright exists”, and “write prohibited”.

Hexadecimal → Binary Conversion Table

Hexadecimal	Binary	Hexadecimal	Binary
0	0000	8	1000
1	0001	9	1001
2	0010	A	1010
3	0011	B	1011
4	0100	C	1100
5	0101	D	1101
6	0110	E	1110
7	0111	F	1111

CD SECTION

CD TEXT DISPLAY

- This unit displays CD text.

Text is displayed for the first 50 tracks only and will not be displayed from the 51st track onwards. Do not suspect a fault in this case.

In some cases, some special characters will not be displayed and may be replaced by other characters. Do not suspect a fault in this case.

AGING MODE

- Mode for repeating operations of the CD player automatically.

When errors occur:

Aging stops and a message indicating that an error has occurred such as “CD MEC ERR” is displayed.

(For details of errors, refer to “Error History Display Mode”)

When no errors occur:

Aging is repeatedly performed.

Procedure:

1. Load any CD disc.
2. Press the **[FUNCTION]** button to set the CD function.
3. While pressing the **[PLAY MODE/TUNING MODE]** and **[▶▶] (MD)** buttons, press the **[I/⏻]** button.
4. “AGING” is displayed on the fluorescent display tube briefly.
5. When the aging mode is set, it starts aging automatically.
6. Operations are performed in the following sequence during aging.

Aging mode sequence:

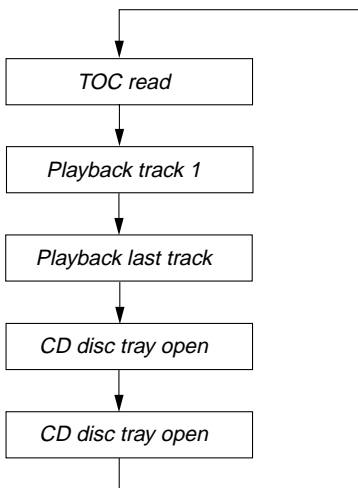

7. To release from this mode, while pressing the **[PLAY MODE/TUNING MODE]** and **[▶▶] (CD)** buttons, press the **[I/⏻]** button. (Hot reset is executed)

Error History Display Mode

Mode for checking the history of errors which have occurred in the CD player.

Execute this mode after ending the aging mode.

Procedure:

1. Press the **[FUNCTION]** button to set the CD function.
2. While pressing the **[▶▶] [▶▶▶]** and **[□] (MD)** buttons, press the **[I/⏻]** button.
3. “EMC@@EDC**” is displayed.
@@ : Number of mechanism errors (Past 3 errors)
** : Number of errors (NO DISC ERROR) which occurred after chucking (Past 3 errors)
4. To check the history of mechanism errors, press the **[PLAY MODE/TUNING MODE]** button, and to check BD errors, press the **[REPEAT]** button, and switch the display.
5. To release, press the **[I/⏻]** button and turn the power off.
6. To erase the error history, perform COLD reset.
(While pressing the **[PLAY MODE/TUNING MODE]** and **[□] (CD)** buttons, press the **[I/⏻]** button)

• **Reading the Mechanism Error History Display**

(To switch the history, press the **PLAY MODE/TUNING MODE** button)

Display

E@@M*\$***

- @@ : Error number. 00 is the latest
- * : Invalid
- # : Load in operations related
 - D : Operations stopped due to problems other than mechanism related during CLOSE
 - E : Operations stopped due to problems other than mechanism related during OPEN
 - C : Operations stopped due to problems other than mechanism related during chucking up
- \$: Load out operations related
 - 1 : Operations stopped during chucking up
 - 2 : Operations stopped during chucking down

• **Reading the BD Error History Display**

(To switch the history, press the **REPEAT** button)

Display

E@@D##\$\$%*

- @@ : Error number. 00 is the latest
- ## : Error details
 - 01 : Focus error
 - 02 : GFS error
 - 03 : Setup error
- \$\$: Retry performed/not performed
 - 00 : Determined as NO DISC without chucking retry
 - 02 : Determined as NO DISC after chucking retry
- % : State when determined as NO DISC
 - 1 : When stopped
 - 2 : During setup
 - 3 : During TOC READ
 - 4 : During access
 - 5 : During playback
 - 6 : During PAUSE
 - 7 : During manual search (during playback)
 - 8 : During manual search (during pause)
- * : Invalid

SECTION 2 GENERAL

This section is extracted from instruction manual.

LOCATION OF CONTROLS

• Front View

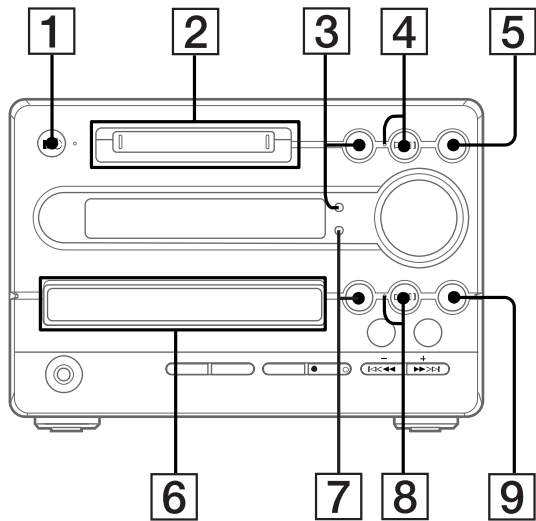

- 1 I/⏻ button and indicator
- 2 MD disc slot
- 3 MD ⏪ button and MD disc indicator
- 4 MD ▷⏸ button and indicator
- 5 MD □ button
- 6 CD disc tray
- 7 CD ⏪ button and CD disc indicator
- 8 CD ▷⏸ button and indicator
- 9 CD □ button

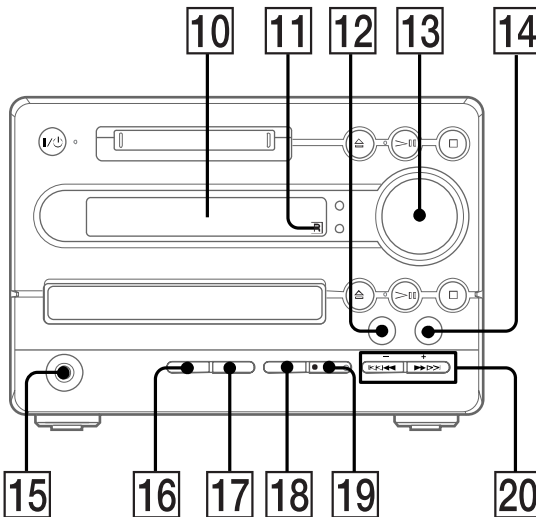

- 10 Fluorescent indicator tube
- 11 Remote sensor
- 12 TUNER/BAND button
- 13 VOLUME knob
- 14 FUNCTION button
- 15 PHONES jack
- 16 PLAY MODE, TUNING MODE button
- 17 REPEAT, STEREO/MONO button
- 18 CD-MD SYNC button
- 19 ●REC button and indicator
- 20 MD/CD ⏮⏪ ⏩⏭, TUNING +/- buttons

• Rear View

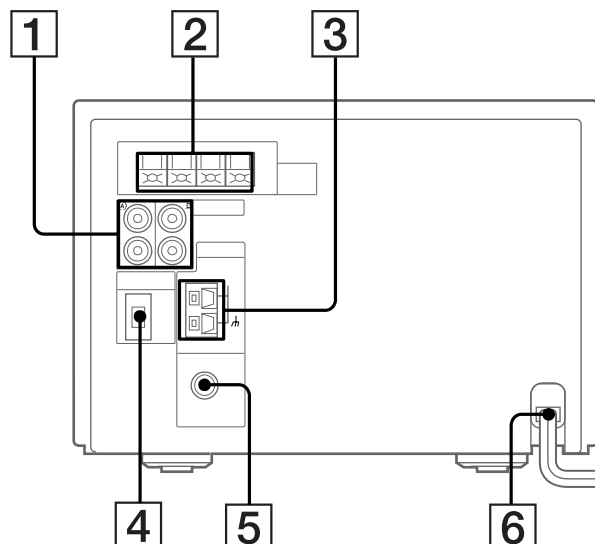

- 1 TAPE IN/OUT jacks
- 2 SPEAKER IMPEDANCE 6-16 Ω terminals
- 3 AM ANTENNA terminals
- 4 TAPE CONTROL jack
- 5 FM 75 Ω COAXIAL jack
- 6 AC power cord

Parts descriptions for the remote

You can use the supplied remote to control the system.

Note

You cannot perform the following operations with the remote:

- TUNING MODE setting for the tuner
- STEREO/MONO setting for the tuner
- Removing discs
- Recording on the MD
- One Touch Play

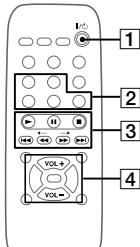

1 I/O (power) switch

2 The sound source buttons

MD button

CD button

TAPE button

FUNCTION button

Press to switch the sound source.

Each time you press this button, the sound source changes as follows;

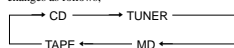

TUNER/BAND button

Press to select the tuner for the sound source, or to select the FM or AM band.

3 ► (play) button

II (pause) button

■ (stop) button

CURSOR ←/→, ◀/▶ buttons

Press to label a CD, MD and preset station, or to set the clock. (pages 5, 18, 35, 45)

◀◀/▶▶ (AMS: Automatic Music Sensor) buttons

4 VOL +/- buttons

Press to adjust the volume.

MENU/NO button

Press to set Programme Play, or to label a CD, MD and preset station.

ENTER/YES button

Press to set the clock, Programme Play and to label a CD, MD and preset station, or to enter the settings in "Edit Menu" or "Setup Menu".

DISP button

Press to show the various information. (pages 17 and 23)

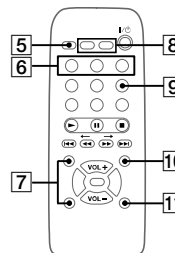

5 SLEEP button

Press to set Sleep Timer. (page 46)

6 PLAY MODE button

Press to select normal play, Shuffle Play or Programme Play. (pages 15, 16, 21, 25)

REPEAT button

Press to play a track or all the tracks repeatedly (pages 15 and 20).

MUSIC MENU button

Press to select the type of the preset equalizer. (page 44)

7 NAME EDIT buttons

CHARACTER button

Press to display the text input screen and to select the type of characters to be input. (pages 19, 35, 45)

SPACE button

Press to enter a space directly when labelling a CD, MD and preset station. (pages 19, 36, 46)

8 CLOCK/TIMER SELECT button

Press to check timer settings, or to set the timer on/off. (pages 48 and 49)

CLOCK/TIMER SET button

Press to set the clock and timer functions. (pages 5, 47, 48)

9 DBFB button

Press to reinforce the bass sound. (page 44)

10 SCROLL button

Press to display the disc title or track title scrolling. (pages 19, 23, 36)

11 CLEAR button

Press to cancel the selection. (pages 16, 18, 21, 35, 45)

60

Step 2: Setting the time

You must set the time beforehand to use the timer functions.

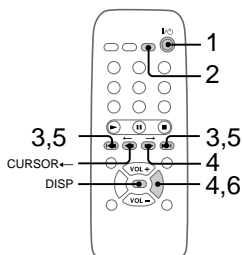

1 Turn on the system.

2 Press CLOCK/TIMER SET.

The clock appears and the hour indication flashes.



3 Press ◀◀ or ▶▶ to set the hour.



4 Press ENTER/YES or CURSOR →.

The minute indication flashes.

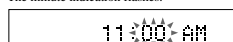

continued

Step 2: Setting the time (continued)

5 Press ◀◀ or ▶▶ to set the minute.

6 Press ENTER/YES.

The clock starts.

If you made a mistake

Press CURSOR ← or → repeatedly until the incorrect item flashes, then set it again.

To change the preset time

You can change the preset time while the system is off.

1 Press DISP to display the clock.

2 Press CLOCK/TIMER SET.

3 Repeat steps 3 to 6 of "Setting the time".

Tip

The upper dot of the colon flashes for the first 30 seconds, and the lower dot flashes for the last 30 seconds of each minute.

Getting Started

5

6

Additional Information

61

SECTION 3 DISASSEMBLY

Note: Follow the disassembly procedure in the numerical order given.

CASE

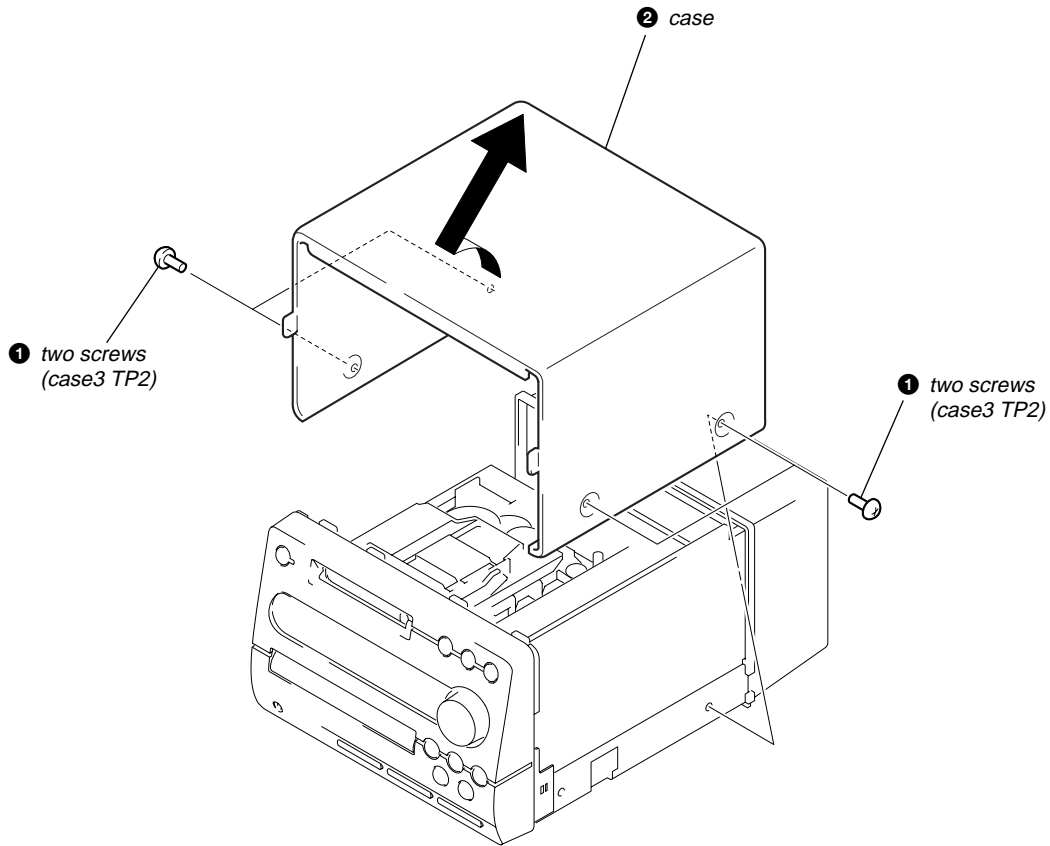

FRONT PANEL SECTION

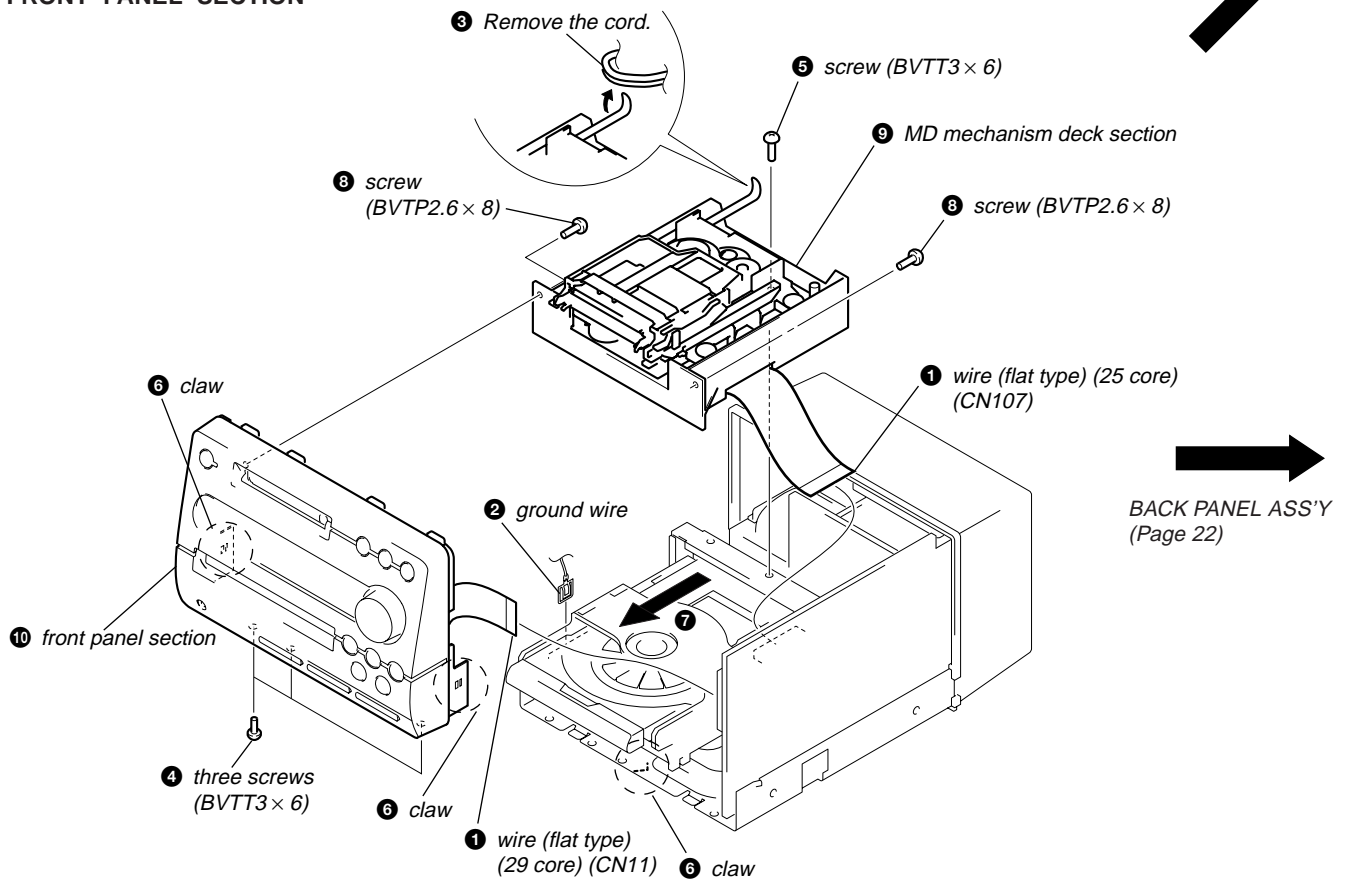

MD MECHANISM DECK (MDM-5GA)

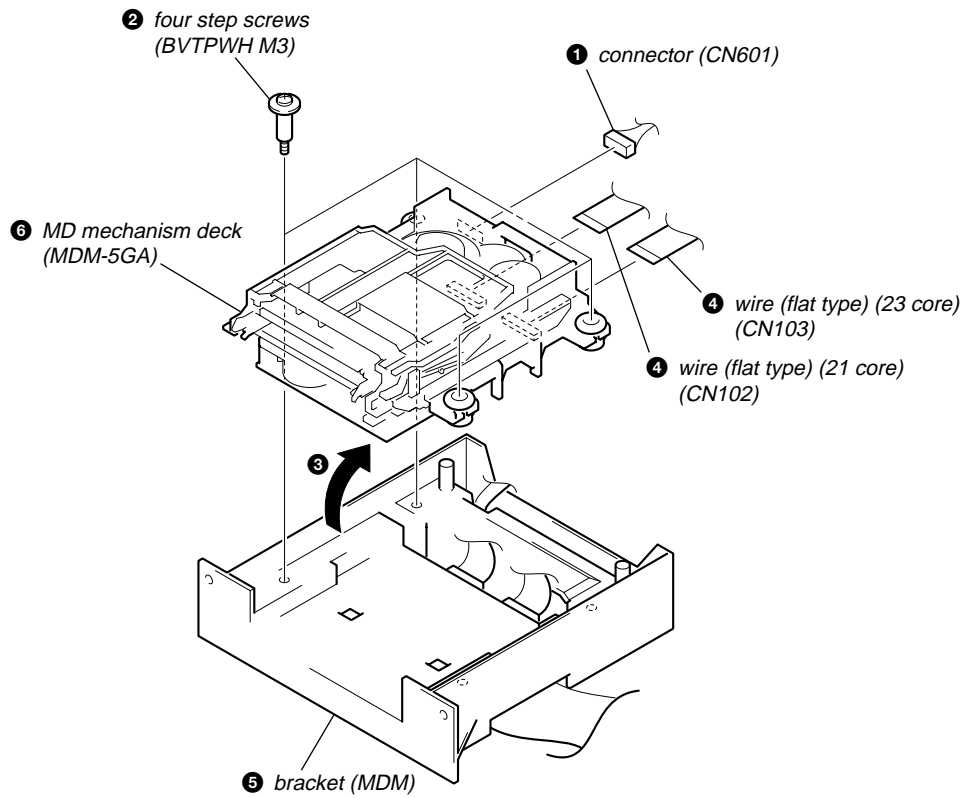

SLIDER (CAM)

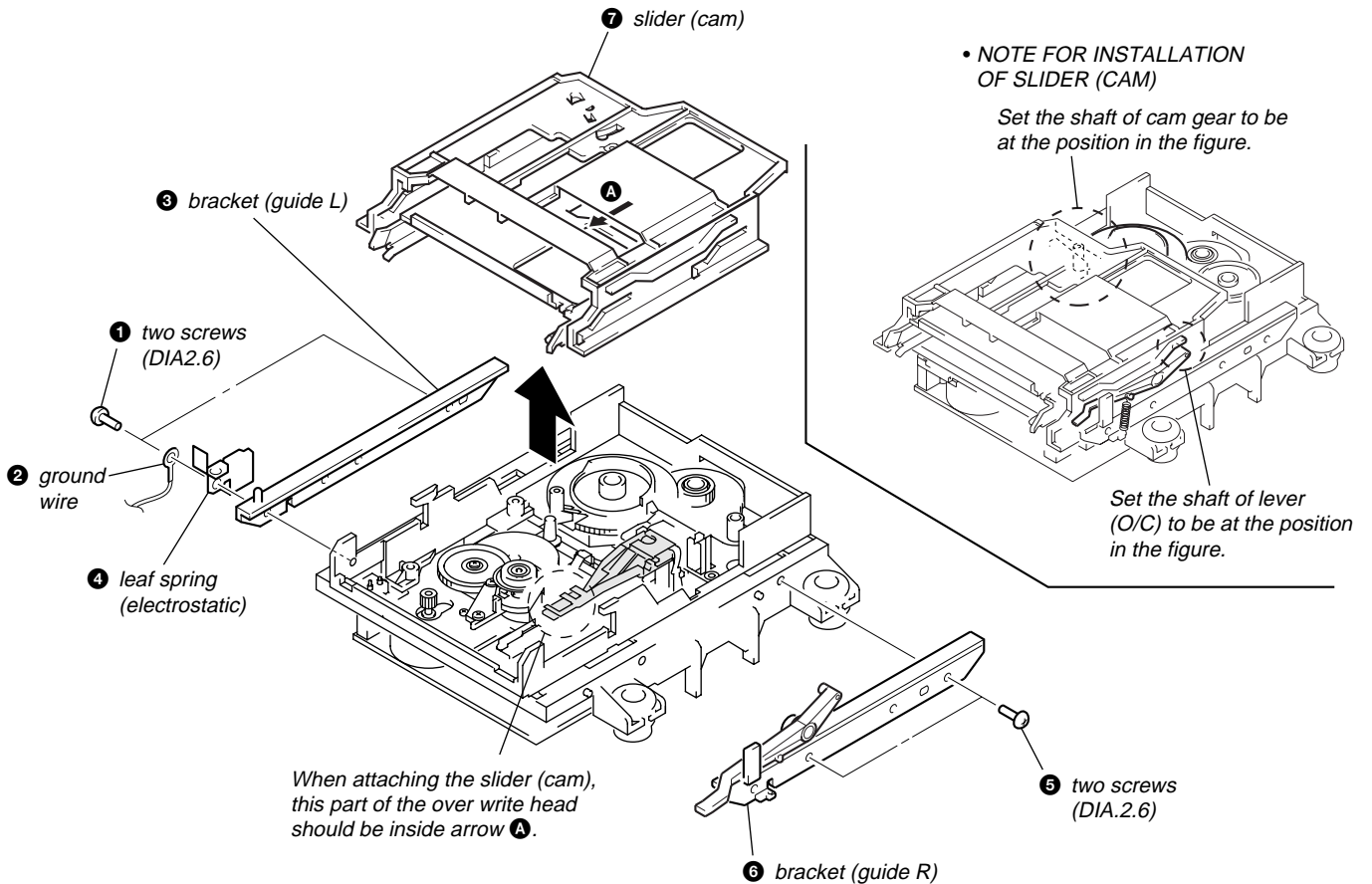

BD (MD) BOARD, BASE UNIT (MBU-5A)

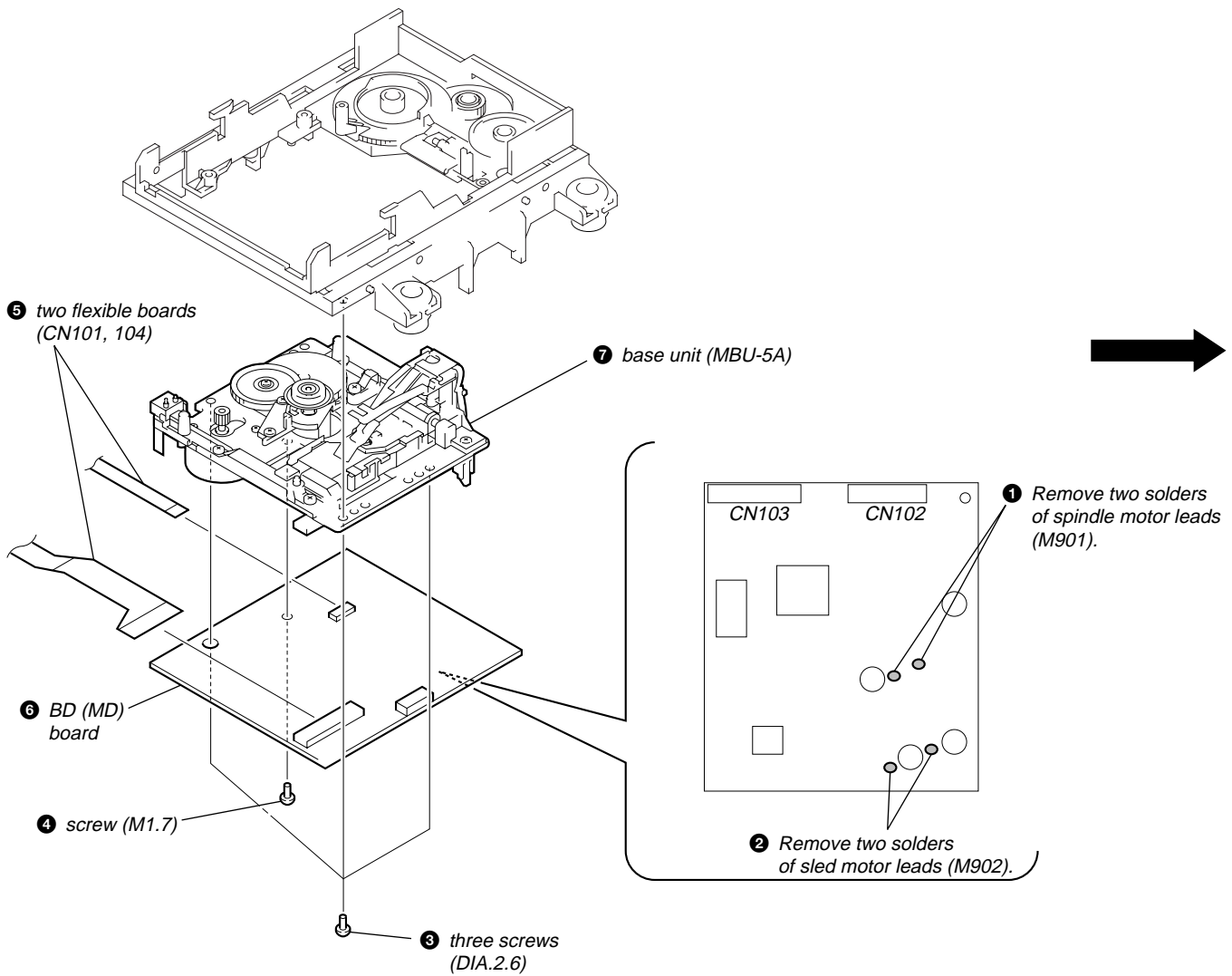

OVER WRITE HEAD (HR901)

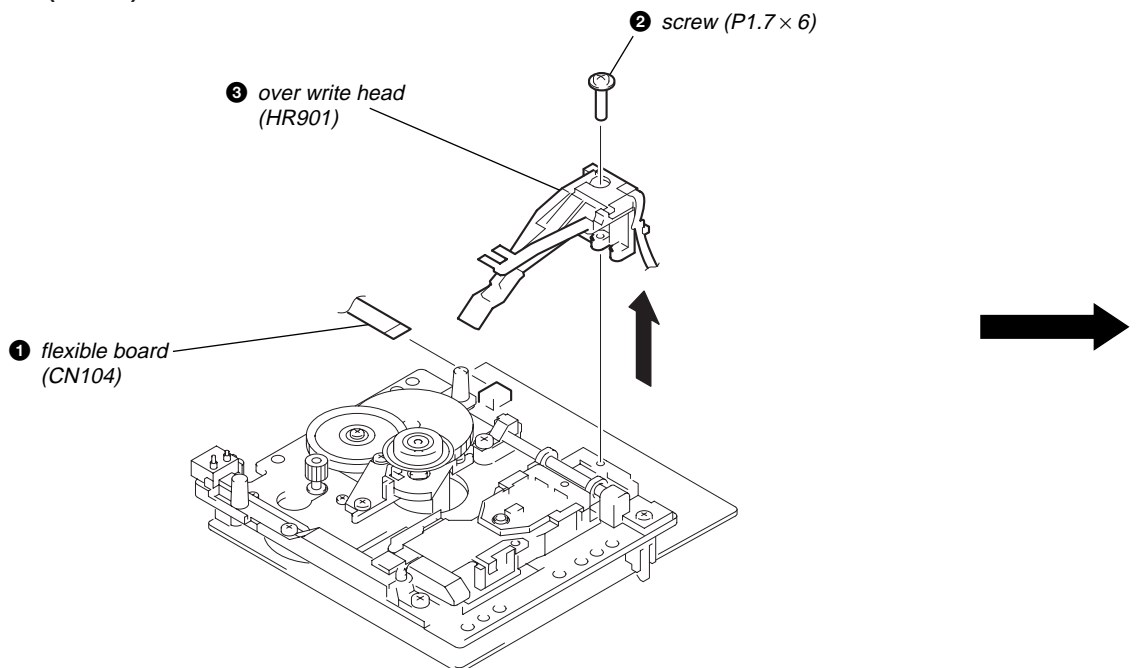

SPINDLE MOTOR ASS'Y (M901), SLED MOTOR ASS'Y (M902)

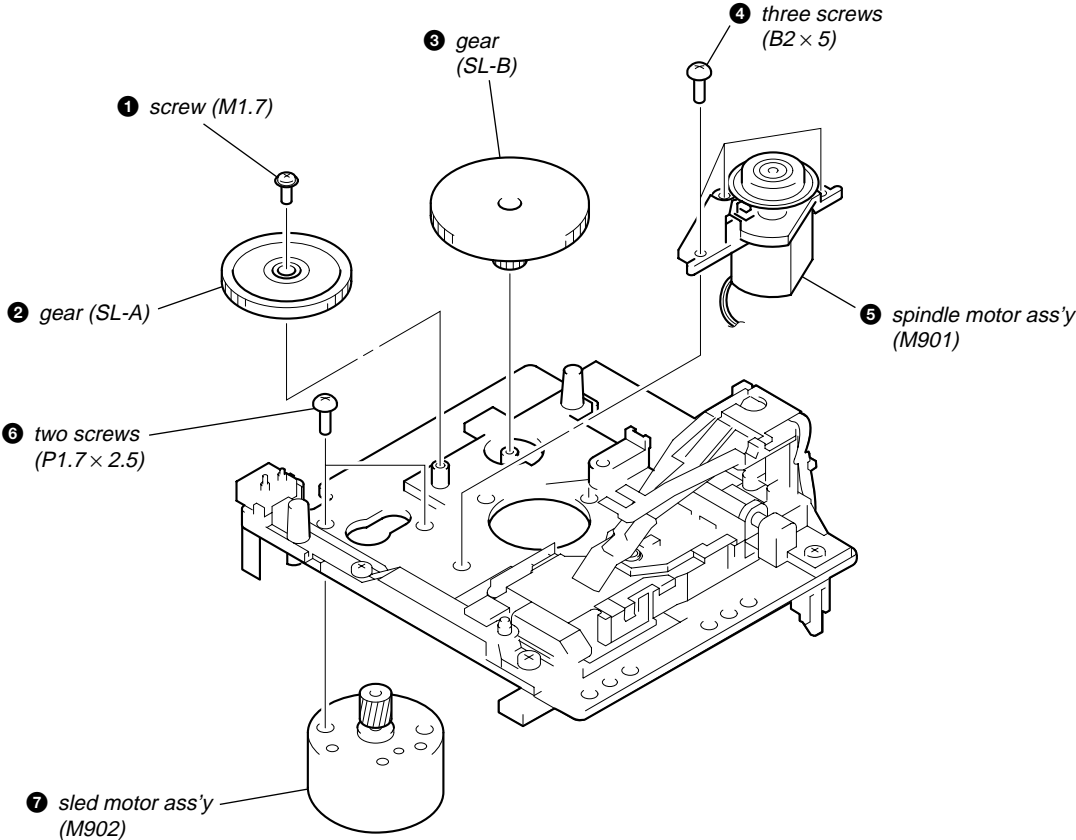

OPTICAL PICK-UP OF MD (KMS-260B/S1NP)

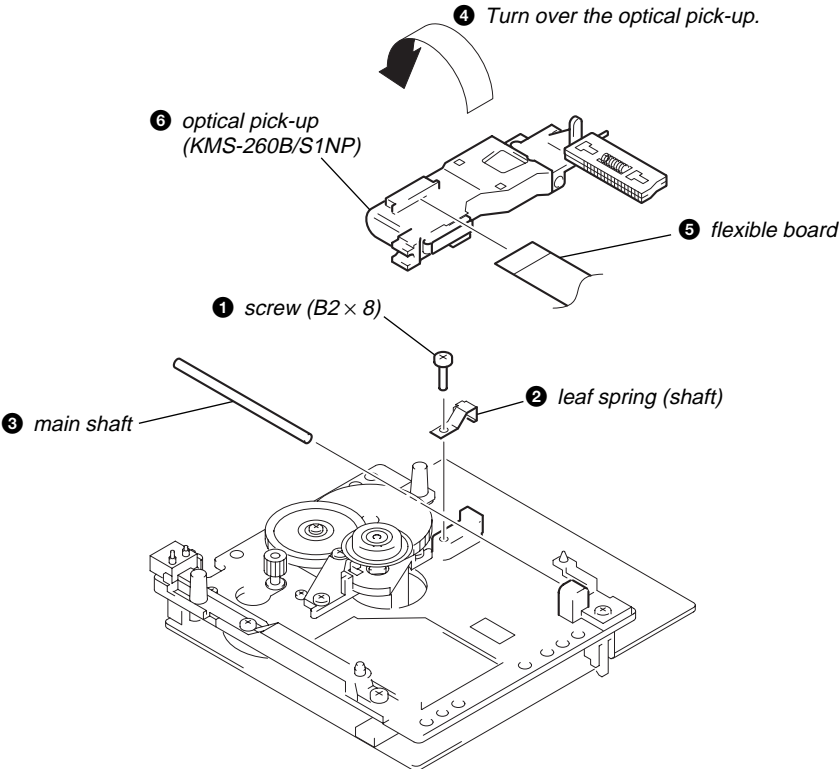

BACK PANEL ASS'Y

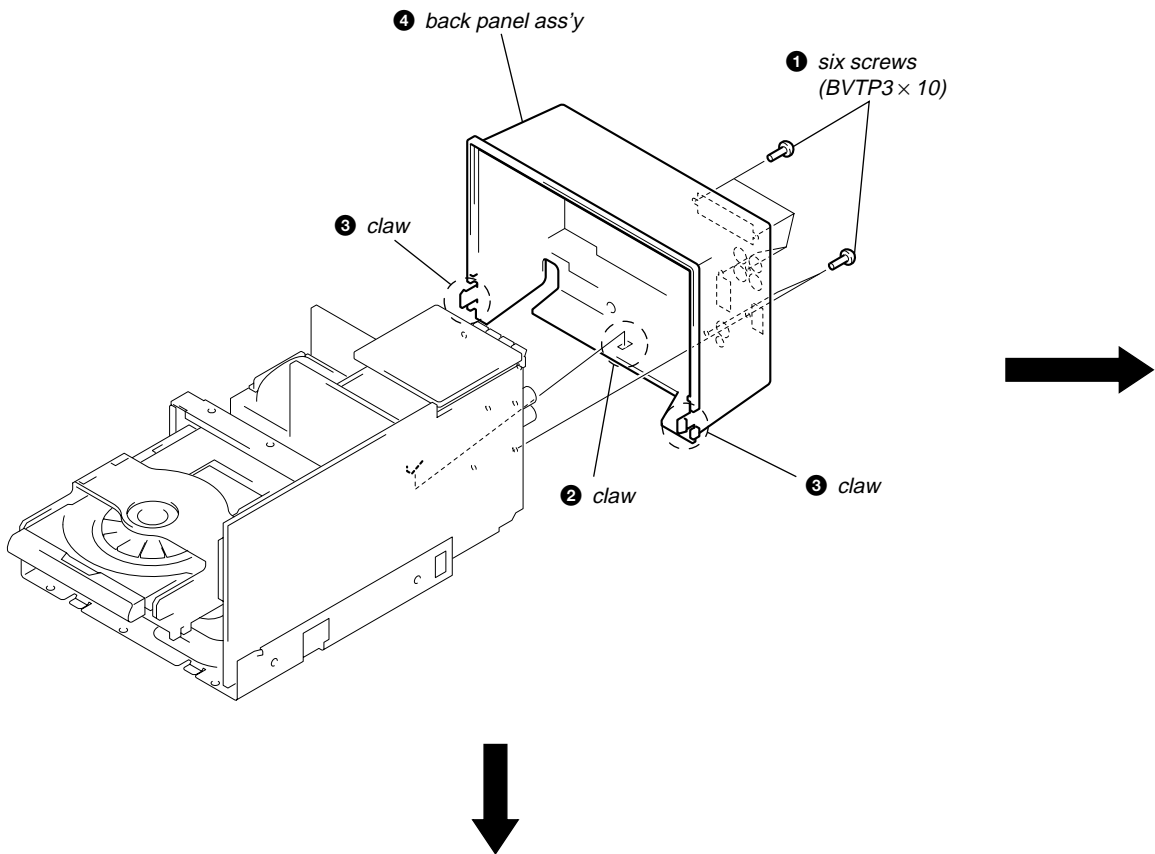

SP BOARD, POWER BOARD AND MAIN BOARD

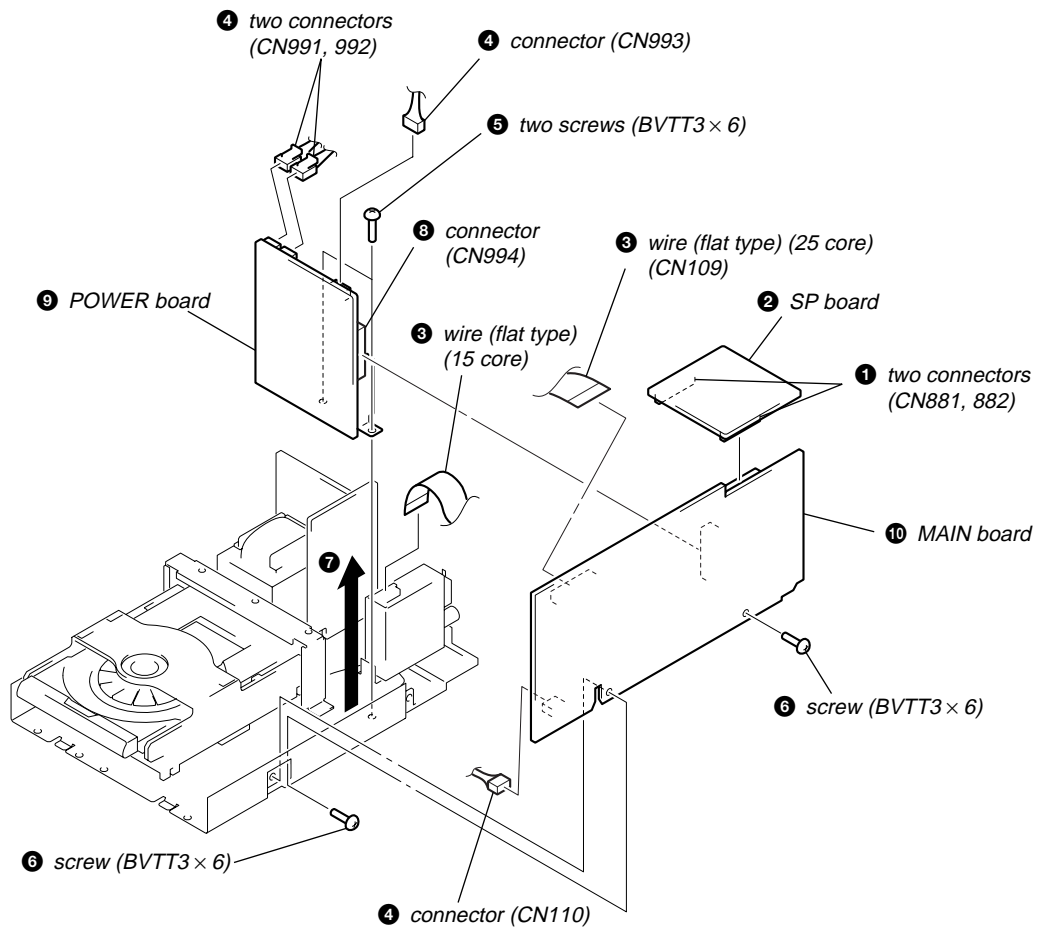

CD MECHANISM DECK (CDM55A-5SBD32)

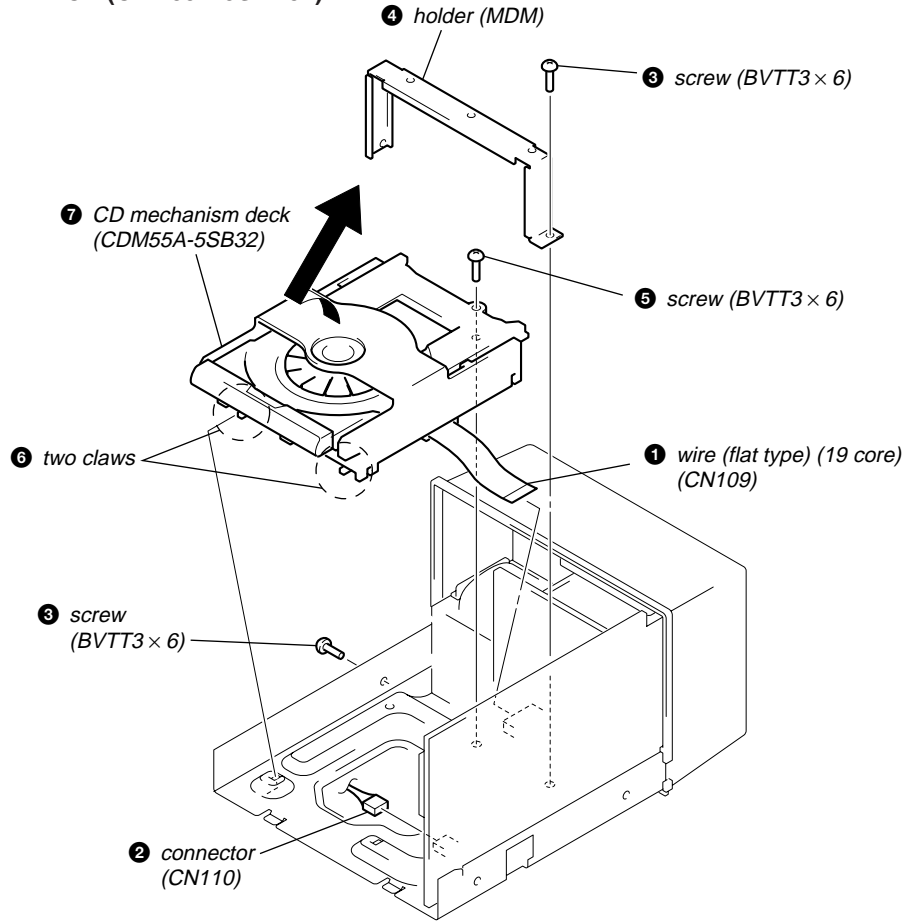

TRAY (CDM), GEAR AND CAM (CDM55)

Note: when drawing out the tray (CDM), refer to service notes DRAWING OUT THE TRAY WHEN THE POWER IS OFF on page 6.

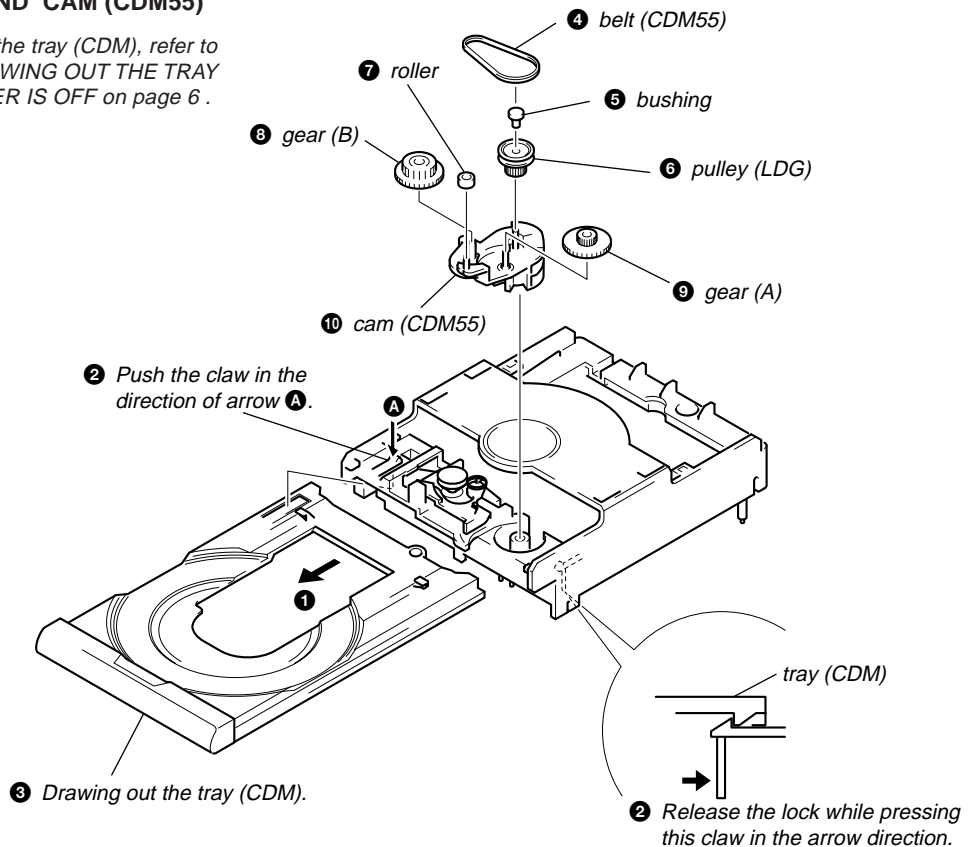

HOLDER (BU) ASS'Y

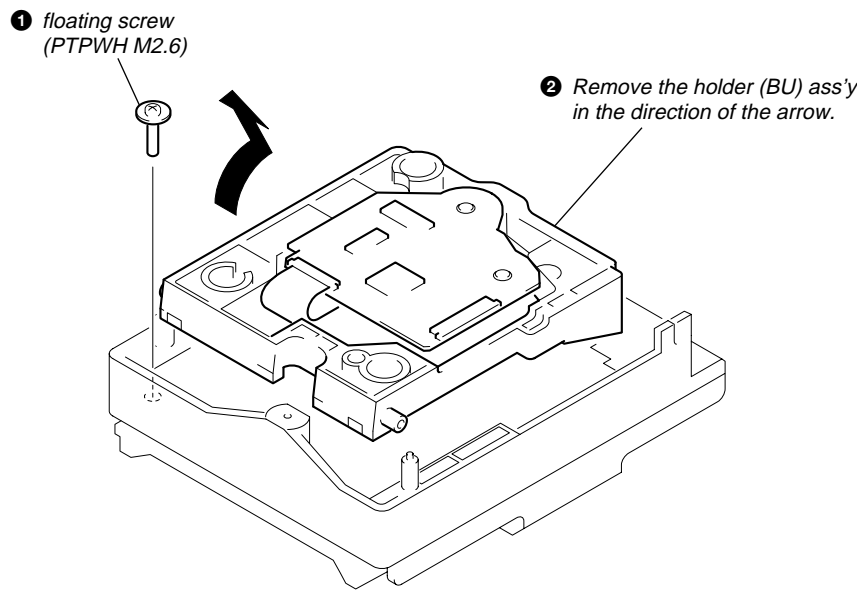

OPTICAL PICK-UP OF CD (KSS-213BH/Z-NP)

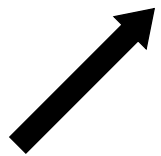
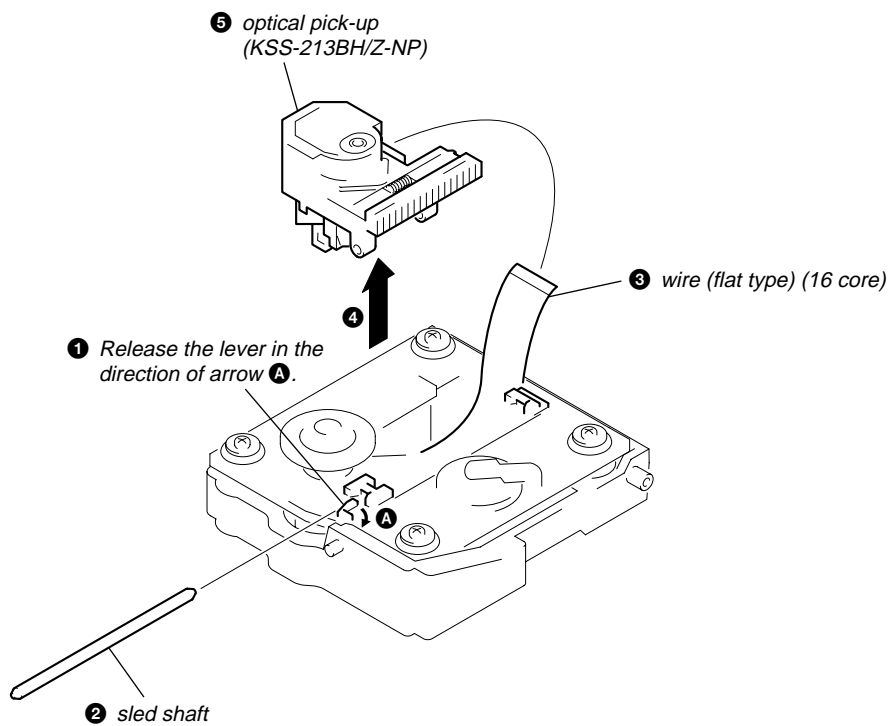

BD (CD) BOARD, BASE (BU-5S) ASS'Y (M101) AND SLED MOTOR ASS'Y (M102)

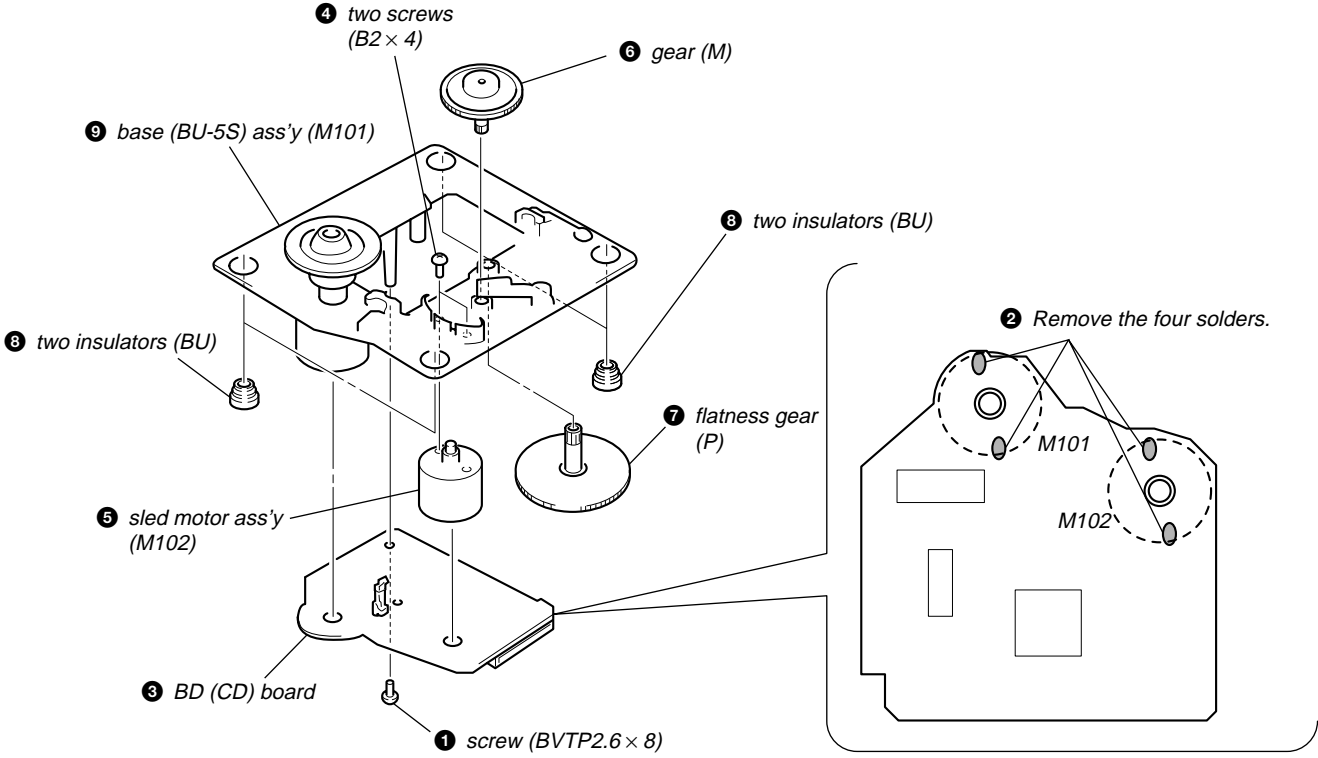

SECTION 4 TEST MODE

Note : About “R”

As this unit has only a few buttons, some operations require the use of remote commander (RM-SF3MD/provided with unit: 1-476-068-11) buttons. These operations are indicated as “R” in this manual.

Example: [MENU/NO “R”] ...Press the [MENU/NO] button of the remote commander.

4-1. PRECAUTIONS FOR USE OF TEST MODE

- As loading related operations will be performed regardless of the test mode operations being performed, be sure to check that the disc is stopped before setting and removing it.
Even if the [MD] button is pressed while the disc is rotating during continuous playback, continuous recording, etc., the disc will not stop rotating.
Therefore, it will be ejected while rotating.
Be sure to press the [MD] button after pressing the [MENU/NO “R”] button and the rotation of disc is stopped.

4-1-1. Recording laser emission mode and operating buttons

- Continuous recording mode (CREC MODE)
- Laser power check mode (LDPWR CHECK)
- Laser power adjustment mode (LDPWR ADJUST)
- Traverse (MO) check (EF MO CHECK)
- Traverse (MO) adjustment (EF MO ADJUST)
- When pressing the [●REC] button.

4-2. SETTING THE TEST MODE

The following are two methods of entering the test mode.

- Procedure 1:**
1. Press the [I/⏻] button to turn the power on.
 2. Press the [FUNCTION] button to set the MD function.
 3. While pressing the [MD] and [●REC] buttons, press the [I/⏻] button to enter the MD test mode and display “[Check]”.
When the test mode is set, “[Check]” will be displayed. Press the [◀◀] or [▶▶] button switches between the following four groups; ...↔ [Check] ↔ [Adjust] ↔ [Service] ↔ [Develop] ↔ ...

- Procedure 2:**
1. Press the [I/⏻] button to turn the power on.
 2. Press the [FUNCTION] button to set the MD function.
 3. While pressing the [MD] and [CD-MD SYNC] buttons, press the [I/⏻] button to enter the MD test mode and display “TEMP CHECK”.
By setting the test mode using this method, only the “Check” group of method 1 can be executed.

4-3. RELEASING THE TEST MODE





Press the [REPEAT] button.

4-4. BASIC OPERATIONS OF THE TEST MODE

All operations are performed using the [◀◀] or [▶▶] button, [ENTER/YES “R”] button, and [MENU/NO “R”] button. The functions of these buttons are as follows.

Function name	Function
[◀◀], [▶▶] buttons	Changes parameters and modes
[ENTER/YES “R”] button	Proceeds onto the next step. Finalizes input
[MENU/NO “R”] button	Returns to previous step. Stops operations

4-5. SELECTING THE TEST MODE

There are 31 types of test modes as shown below. The groups can be switched by pressing the  or  button. After selecting the group to be used, press the  button. After setting a certain group, press the  or  button switches between these modes.

Refer to “Group” in the table for details can be selected.

All items used for servicing can be treated using group S. So be carefully not to enter other groups by mistake.

Display	Contents	Mark	Group (*)
TEMP CHECK	Temperature compensation offset check		C S
LDPWR CHECK	Laser power check		C S
EF MO CHECK	Traverse (MO) check		C S
EF CD CHECK	Traverse (CD) check		C S
FBIAS CHECK	Focus bias check		C S
Scurve CHECK	S letter check	(X)	C
VERIFYMODE	Non-volatile memory check	(X)	C
DETRK CHECK	Detrack check	(X)	C
TEMP ADJUST	Temperature compensation offset adjustment		A S
LDPWR ADJUST	Laser power adjustment		A S
EF MO ADJUST	Traverse (MO) adjustment		A S
EF CD ADJUST	Traverse (CD) adjustment		A S
FBIAS ADJUST	Focus bias adjustment		A S
EEP MODE	Non-volatile memory control	(X) (!)	D
MANUAL CMD	Command transmission	(X)	D
SVDATA READ	Status display	(X)	D
ERR DP MODE	Error history display, clear		S
SLED MOVE	Sled check	(X)	D
ACCESS MODE	Access check	(X)	D
0920 CHECK	Outermost circumference check	(X)	D
HEAD ADJUST	Head position check	(X)	D
CPLAY2 MODE	Same functions as CPLAY MODE	(X)	D
CREC2 MODE	Same functions as CREC MODE	(X)	D
ADJ CLEAR	Initialization of non-volatile memory of adjustment value		A S
AG Set (MO)	Auto gain output level adjustment (MO)		A S
AG Set (CD)	Auto gain output level adjustment (CD)		A S
Iop Read	IOP data display		C S
Iop Write	IOP data write		A S
INFORMATION	Microprocessing version display		C S
CPLAY MODE	Continuous playback mode		C A S D
CREC MODE	Continuous recording mode		C A S D



Group (*)

C: Check

A: Adjust

S: Service

D: Develop

- For details of each adjustment mode, refer to “5. Electrical Adjustments”.
- For details of “ERR DP MODE”, refer to “Self-Diagnosis Function” on page 2.
- If a different mode has been selected by mistake, press the  button to release that mode.
- Modes with (X) in the Mark column are not used for servicing and therefore are not described in detail. If these modes are set accidentally, press the  button to release the mode immediately. Be especially careful not to set the modes with (!) as they will overwrite the non-volatile memory and reset it, and as a result, the unit will not operate normally.

4-5-1. Operating the Continuous Playback Mode

- Entering the continuous playback mode
 - Set the disc in the unit. (Whichever recordable discs or discs for playback only are available.)
 - Press the or button and display “CPLAY MODE”.
 - Press the button to change the display to “CPLAY MID”.
 - When access completes, the display changes to “C1 = AD = .

Note: The numbers “” displayed show you error rates and ADER.

- Changing the parts to be played back
 - Press the button during continuous playback to change the display as below.



When pressed another time, the parts to be played back can be moved.

- When access completes, the display changes to “C1 = AD = .

Note: The numbers “” displayed show you error rates and ADER.

- Ending the continuous playback mode
 - Press the button. The display will change to “CPLAY MODE”.
 - Press the (MD) button and take out the disc.

Note: The playback start addresses for IN, MID, and OUT are as follows.

IN : 40h cluster
 MID : 300h cluster
 OUT : 700h cluster

4-5-2. Operating the Continuous Recording Mode (Use only when performing self-recording/palyback check.)

- Entering the continuous recording mode
 - Set a recordable disc in the unit.
 - Press the or button and display “CREC MODE”.
 - Press the button to change the display to “CREC MID”.
 - When access completes, the display changes to “CREC ()” and indicator lights up.

Note: The numbers “” displayed shows you the recording position addresses.

- Changing the parts to be recorded
 - When the button is pressed during continuous recording, the display changes as below.



When pressed another time, the parts to be recorded can be changed. indicator goes off.

- When access completes, the display changes to “CREC ()” and indicator lights up.

Note: The numbers “” displayed shows you the recording position addresses.

- Ending the continuous recording mode
 - Press the button. The display changes to “CREC MODE” and indicator goes off.
 - Press the (MD) button and take out the disc.

Note 1: The recording start addresses for IN, MID, and OUT are as follows.

IN : 40h cluster
 MID : 300h cluster
 OUT : 700h cluster

Note 2: The button can be used to stop recording anytime.

Note 3: Do not perform continuous recording for long periods of time above 5 minutes.

Note 4: During continuous recording, be careful not to apply vibration.

4-5-3. Non-Volatile Memory Mode (EEP MODE)

This mode reads and writes the contents of the non-volatile memory.

It is not used in servicing. If the unit entered this mode accidentally, press the button immediately to release it.

4-6. FUNCTIONS OF OTHER BUTTONS

Function	Contents
(MD)	Sets continuous playback when pressed in the STOP state. When pressed during continuous playback, the tracking servo turns ON/OFF
(MD)	Stops continuous playback and continuous recording
	The sled moves to the outer circumference only when this is pressed
	The sled moves to the inner circumference only when this is pressed
CLEAR “R”	Switches between the pit and groove modes when pressed
PLAY MODE/TUNING MODE	Switches the spindle servo mode (CLV-S ↔ CLV-A)
DISP “R”	Switches the displayed contents each time the button is pressed
(MD)	Ejects the disc
REPAET	Releases the test mode

4-7. TEST MODE DISPLAYS

Each time the [DISP "R"] button is pressed, the display changes in the following order.

1. Mode display

Displays "TEMP ADJUST", "CPLAYMODE", etc.

2. Error rate display

Displays the error rate in the following way.

C1 = □□□□ AD = □□

C1 = Indicates the C1 error.

AD = Indicates ADER.

3. Address display

The address is displayed as follows. (MO: recordable disc, CD: playback only disc)

Press the [CLEAR "R"] button to switches between the groove display and pit display.

h = □□□□ s = □□□□ (MO pit and CD)

h = □□□□ a = □□□□ (MO groove)

h = Indicates the header address.

s = Indicates the SUBQ address.

a = Indicates the ADIP address.

Note: "—" is displayed when servo is not imposed.

4. Auto gain display (Not used in servicing)

The auto gain is displayed as follows.

AG = □□/□□[□□]

5. Detrack check display (Not used in servicing)

The detrack is displayed as follows.

ADR = □□□□□□

6. IVR display (Not used in servicing)

The IVR is displayed as follows.

[□□][□□][□□]

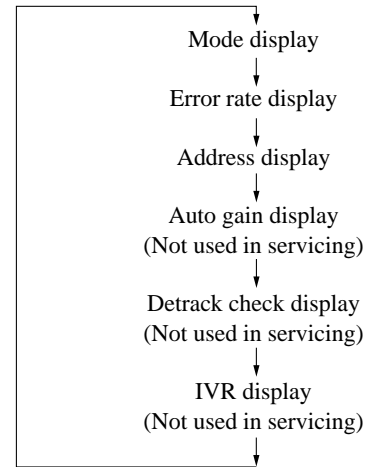

MEANINGS OF OTHER DISPLAYS

Display	Contents	
	When Lit	When Off
▷ (MD)*	During continuous playback (CLV: ON)	STOP (CLV: OFF)
▢▢ (MD)*	Tracking servo OFF	Tracking servo ON
●REC*	Recording mode ON	Recording mode OFF
SYNC	CLV low speed mode	CLV normal mode
L.SYNC	ABCD adjustment completed	
OVER	Tracking offset cancel ON	Tracking offset cancel OFF
1	Tracking auto gain OK	
REPEAT	Focus auto gain OK	
DISC	High reflection	Low reflection
SHUF	CLV-S	CLV-A
MONO	CLV LOCK	CLV UNLOCK

* : Indicate by LED.

SECTION 5 ELECTRICAL ADJUSTMENTS

MD SECTION

5-1. PARTS REPLACEMENT AND ADJUSTMENT

- Check and adjust the mechanism deck as follows.
The procedure changes according to the part replaced

- Abbreviation
OP : Optical pick-up
OWH : Overwrite head

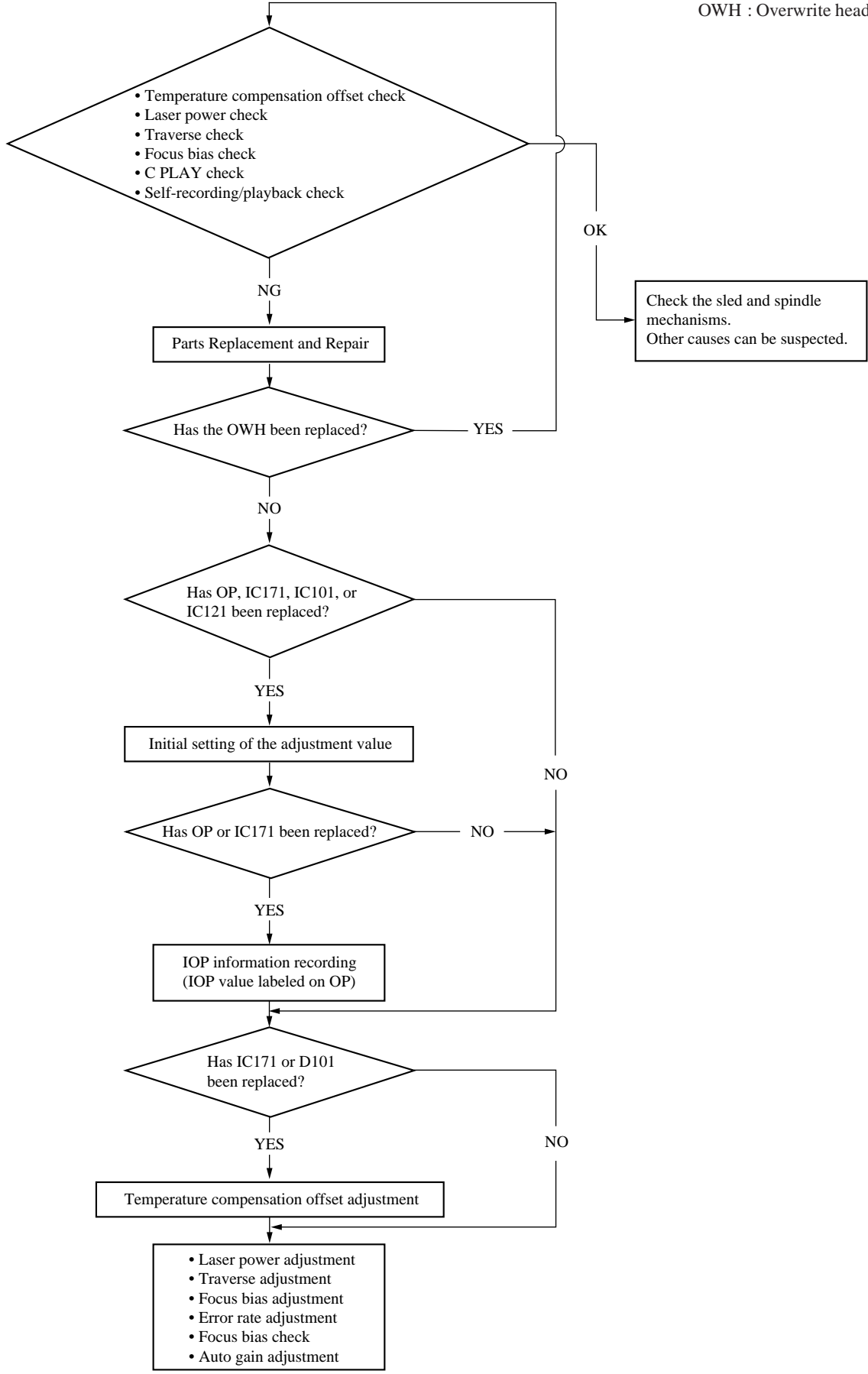

Note : About “R”

As this unit has only a few buttons, some operations require the use of remote commander (RM-SF3MD/provided with unit: 1-476-068-11) buttons. These operations are indicated as “R” in this manual.

Example: **[MENU/NO “R”]** ...Press the **[MENU/NO]** button of the remote commander.

5-2. PRECAUTIONS FOR CHECKING LASER DIODE EMISSION

To check the emission of the laser diode during adjustments, never view directly from the top as this may lose your eye-sight.

5-3. PRECAUTIONS FOR USE OF OPTICAL PICK-UP (KMS-260B)

As the laser diode in the optical pick-up is easily damaged by static electricity, solder the laser tap of the flexible board when using it. Before disconnecting the connector, desolder first. Before connecting the connector, be careful not to remove the solder. Also take adequate measures to prevent damage by static electricity. Handle the flexible board with care as it breaks easily.

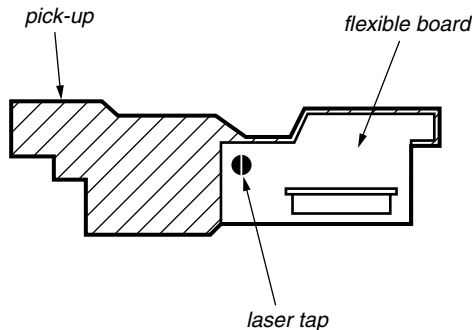

Optical pick-up flexible board

5-4. PRECAUTIONS FOR ADJUSTMENTS

- When replacing the following parts, perform the adjustments and checks with ○ in the order shown in the following table.

	Optical Pick-up	BD Board			
		IC171	D101	IC101, IC121	IC192
1. Initial setting of adjustment value	○	○	×	○	×
2. Recording of IOP information (Value on the optical pick-up label)	○	○	×	×	×
3. Temperature compensation offset adjustment	×	○	○	×	×
4. Laser power adjustment	○	○	×	○	○
5. Traverse adjustment	○	○	×	○	×
6. Focus bias adjustment	○	○	×	○	×
7. Error rate check	○	○	×	○	×
8. Auto gain output level adjustment	○	○	×	○	×

- Set the test mode when performing adjustments. After completing the adjustments, release the test mode. Perform the adjustments and checks in “group S” of the test mode.
- Perform the adjustments to be needed in the order shown.
- Use the following tools and measuring devices.
 - Check Disc (MD) TDYS-1 (Part No. 4-963-646-01)
 - Test Disc (MDW-74/AU-1) (Part No. 8-892-341-41)
 - Laser power meter LPM-8001 (Part No. J-2501-046-A) or MD Laser power meter 8010S (Part No. J-2501-145-A)
 - Oscilloscope (Measure after performing CAL of prove)
 - Digital voltmeter
 - Thermometer
 - Jig for checking BD board waveform (Part No. : J-2501-149-A)
- When observing several signals on the oscilloscope, etc., make sure that VC and ground do not connect inside the oscilloscope. (VC and ground will become short-circuited)
- Using the above jig enables the waveform to be checked without the need to solder. (Refer to Servicing Notes on page 9)
- As the disc used will affect the adjustment results, make sure that no dusts nor fingerprints are attached to it.

Laser power meter

When performing laser power checks and adjustment (electrical adjustment), use of the new MD laser power meter 8010S (Part No. J-2501-145-A) instead of the conventional laser power meter is convenient.

It sharply reduces the time and trouble to set the laser power meter sensor onto the objective lens of optical pick-up.

5-5. CREATING CONTINUOUSLY-RECORDED DISC

* This disc is used in focus bias adjustment and error rate check. The following describes how to create a continuous recording disc.

- Insert a disc (blank disc) commercially available.
- Press the **[◀◀ ◀▶]** or **[▶▶ ▶▶]** button and display “CREC MODE”.
- Press the **[ENTER/YES “R”]** button again to display “CREC MID”. Display “CREC (0300)” and start to recording.
- Complete recording within 5 minutes.
- Press the **[MENU/NO “R”]** button and stop recording .
- Press the **[⏏ (MD)]** button and remove the disc.

The above has been how to create a continuous recorded data for the focus bias adjustment/check and MO error rate check.

Note :

- Be careful not to apply vibration during continuous recording.

5-6. CHECK PRIOR TO REPAIRS

These checks are performed before replacing parts according to “approximate specifications” to determine the faulty locations. For details, refer to “Checks Prior to Parts Replacement and Adjustments” (See page 11).

5-6-1. Temperature Compensation Offset Check

When performing adjustments, set the internal temperature and room temperature of 22 °C to 28 °C.

Checking Procedure:

1. Press the \lll or \ggg button to display “TEMP CHECK”.
2. Press the ENTER/YES "R" button.
3. “T=@@ (##) [OK]” should be displayed. If “T=@@ (##) [NG]” is displayed, it means that the results are bad.
(@@ indicates the current value set, and ## indicates the value written in the non-volatile memory)

5-6-2. Laser Power Check

Before checking, check the IOP value of the optical pick-up.
(Refer to 8. Recording and Displaying IOP Information)

Connection :

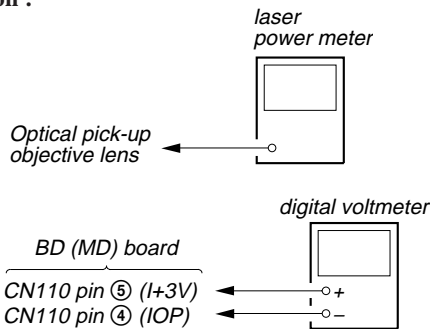

Checking Procedure:

1. Set the laser power meter on the objective lens of the optical pick-up. (When it cannot be set properly, press the \lll button or \ggg button to move the optical pick-up) Connect the digital voltmeter to CN110 pin 5 (I+3V) and CN110 pin 4 (IOP) on the BD (MD) board.
2. Then, press the \lll or \ggg button to display “LDPWR CHECK”.
3. Press the ENTER/YES "R" button once to display “LD 0.9 mW \$ ”. Check that the reading of the laser power meter become 0.84 to 0.92 mW.
4. Press the ENTER/YES "R" button once more to display “LD 7.0 mW \$ ”. Check that the reading the laser power meter and digital voltmeter satisfy the specified value.

Specified Value:

Laser power meter reading : 7.0 ± 0.2 mW

Digital voltmeter reading : Value on the optical pick-up label ±10%

(Optical pick-up label)

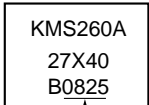

IOP=82.5 mA in this case

$IOP (mA) = \text{Digital voltmeter reading (mV)} / 1 (\Omega)$

5. Press the MENU/NO "R" button to display “LDPWR CHECK” and stop the laser emission.
(The MENU/NO "R" button is effective at all times to stop the laser emission)

Note 1: After step 4, each time the ENTER/YES "R" button is pressed, the display will be switched “LD 0.7 mW \$ ”, “LD 6.2 mW \$ ”, and “LD Wp ホセイ \$ ”. Nothing needs to be performed here.

5-6-3. Traverse Check

Note 1: Data will be erased during MO reading if a recorded disc is used in this adjustment.

Note 2: If the traverse waveform is not clear, connect the oscilloscope as shown in the following figure so that it can be seen more clearly.

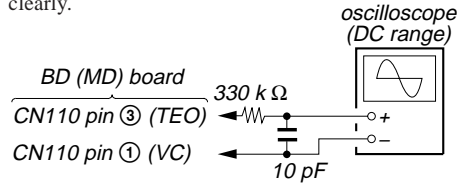

Connection :

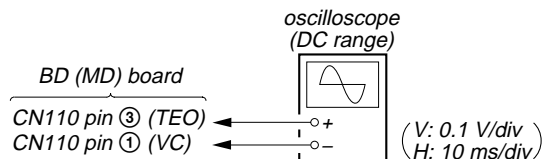

Checking Procedure:

1. Connect an oscilloscope to CN110 pin 3 (TEO) and CN110 pin 1 (VC) on the BD (MD) board.
2. Load a disc (any available on the market). (Refer to Note 1)
3. Press the \ggg button to move the optical pick-up outside the pit.
4. Press the \lll or \ggg button to display “EF MO CHECK”.
5. Press the ENTER/YES "R" button to display “EFB = MO-R”. (Laser power READ power/Focus servo ON/tracking servo OFF/spindle (S) servo ON)
6. Observe the waveform of the oscilloscope, and check that the specified value is satisfied. Do not press the \lll or \ggg button.
(Read power traverse checking)

Traverse Waveform

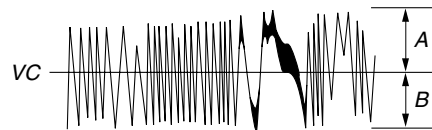

Specified value : Below 10% offset value

$$\text{Offset value (\%)} = \frac{IA - BI}{2(A + B)} \times 100$$

7. Press the ENTER/YES "R" button to display “EFB = MO-W”.
8. Observe the waveform of the oscilloscope, and check that the specified value is satisfied. Do not press the \lll or \ggg button.
(Write power traverse checking)

Traverse Waveform

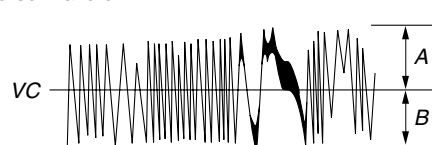

Specified value : Below 10% offset value

$$\text{Offset value (\%)} = \frac{IA - BI}{2(A + B)} \times 100$$

- Press the **ENTER/YES "R"** button to display "EFB = MO-P". Then, the optical pick-up moves to the pit area automatically and servo is imposed.
- Observe the waveform of the oscilloscope, and check that the specified value is satisfied. Do not Press the **◀◀** or **▶▶** button.

Traverse Waveform

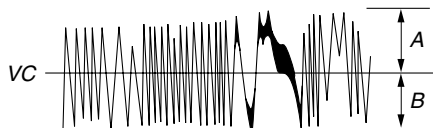

Specified value : Below 10% offset value

$$\text{Offset value (\%)} = \frac{|A - B|}{2(A + B)} \times 100$$

- Press the **ENTER/YES "R"** button to display "EF MO CHECK". The disc stops rotating automatically.
- Press the **(MD)** button and take out the disc.
- Load the check disc (MD) TDYS-1.
- Press the **◀◀** or **▶▶** button and display "EF CD CHECK".
- Press the **ENTER/YES "R"** button to display "EFB = CD". Servo is imposed automatically.
- Observe the waveform of the oscilloscope, and check that the specified value is satisfied. Do not press the **◀◀** or **▶▶** button.

Traverse Waveform

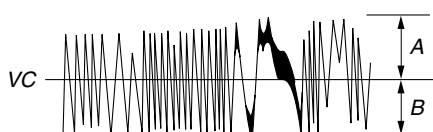

Specified value : Below 10% offset value

$$\text{Offset value (\%)} = \frac{|A - B|}{2(A + B)} \times 100$$

- Press the **ENTER/YES "R"** button to display "EF CD CHECK".
- Press the **(MD)** button and take out the check disc.

5-6-4. Focus Bias Check

Change the focus bias and check the focus tolerance amount.

Checking Procedure :

- Load the test disk (MDW-74/AU-1).
- Press the **◀◀** or **▶▶** button to display "CPLAY MODE".
- Press the **ENTER/YES "R"** button twice to display "CPLAY MID".
- Press the **MENU/NO "R"** button when "C1 = AD = is displayed.
- Press the **◀◀** or **▶▶** button to display "FBIAS CHECK".
- Press the **ENTER/YES "R"** button to display "/c = ". The first four digits indicate the C1 error rate, the two digits after [/] indicate ADER, and the 2 digits after [c =] indicate the focus bias value.
Check that the C1 error is below 50 and ADER is below 2.
- Press the **ENTER/YES "R"** button to display "/b = ". Check that the C1 error is about 200 and ADER is below 2.
- Press the **ENTER/YES "R"** button to display "/a = ". Check that the C1 error is about 200 and ADER is below 2.
- Press the **MENU/NO "R"** button, then press the **(MD)** button and take out the test disc.

5-6-5. C PLAY Check

MO Error Rate Check

Checking Procedure :

- Load the test disk (MDW-74/AU-1).
- Press the **◀◀** or **▶▶** button to display "CPLAY MODE".
- Press the **ENTER/YES "R"** button to display "CPLAY MID".
- The display changes to "C1 = AD = ".
- If the C1 error rate is below 80, check that ADER is below 2.
- Press the **MENU/NO "R"** button to stop playback, then press the **(MD)** button and take out the test disc.

CD Error Rate Check

Checking Procedure :

- Load the check disc (MD) TDYS-1.
- Press the **◀◀** or **▶▶** button to display "CPLAY MODE".
- Press the **ENTER/YES "R"** button twice to display "CPLAY MID".
- The display changes to "C1 = AD = ".
- Check that the C1 error rate is below 50.
- Press the **MENU/NO "R"** button to stop playback, then press the **(MD)** button and take out the check disc.

5-6-6. Self-Recording/playback Check

Prepare a continuous recording disc using the unit to be repaired and check the error rate.

Checking Procedure :

- Load a recordable disc (blank disc).
- Press the **◀◀** or **▶▶** button to display "CREC MODE".
- Press the **ENTER/YES "R"** button to display "CREC MID".
- When recording starts, lights up **REC** indicator and display "CREC @@@@" (@@@@ is the address).
- About 1 minute later, press the **MENU/NO "R"** button to stop continuous recording.
- Press the **◀◀** or **▶▶** button to display "CPLAY MODE".
- Press the **ENTER/YES "R"** button to display "CPLAY MID".
- "C1 = AD = will be displayed.
- Check that the C1 error becomes below 80 and the AD error below 2.
- Press the **MENU/NO "R"** button to stop playback, then press the **(MD)** button and take out the disc.

5-7. INITIAL SETTING OF ADJUSTMENT VALUE

Note:

Mode which sets the adjustment results recorded in the non-volatile memory to the initial setting value. However the results of the temperature compensation offset adjustment will not change to the initial setting value.

If initial setting is performed, perform all adjustments again excluding the temperature compensation offset adjustment.

For details of the initial setting, refer to "5-4. Precautions on Adjustments" and execute the initial setting before the adjustment as required.

Setting Procedure :

- Press the **◀◀** or **▶▶** button to display "ADJ CLEAR".
- Press the **ENTER/YES "R"** button. "Complete!" will be displayed momentarily and initial setting will be executed, after which "ADJ CLEAR" will be displayed.

5-8. RECORDING AND DISPLAYING THE IOP INFORMATION

The IOP data can be recorded in the non-volatile memory. The IOP value on the optical pick-up label and the IOP value after the adjustment will be recorded. Recording these data eliminates the need to read the label on the optical pick-up.

Recording Procedure :

1. Press the \lll or \ggg button to display "Iop Write", and press the ENTER/YES "R" button.
2. The display becomes Ref=@@.@ (@ is an arbitrary number) and the numbers which can be changed will blink.
3. Input the IOP value on the optical pick-up label.
To select the number : Press the \lll or \ggg button.
To select the digit : Press the SYNC REC button.
4. When the ENTER/YES "R" button is pressed, the display becomes "Measu=@@.@." (@ is an arbitrary number).
5. As the adjustment results are recorded for the step 4 value. Leave it as it is and press the ENTER/YES "R" button.
6. "Complete!" will be displayed momentarily. The value will be recorded in the non-volatile memory and the display will become "Iop Write".

Display Procedure :

1. Press the \lll or \ggg button to display "Iop Read".
2. "@@.@/##.#" is displayed and the recorded contents are displayed.
@@.@ indicates the IOP value on the optical pick-up label.
##.# indicates the IOP value after adjustment
3. To end, press the CD-MD SYNC button or MENU/NO "R" button to display "Iop Read".

5-9. TEMPERATURE COMPENSATION OFFSET ADJUSTMENT

Save the temperature data at that time in the non-volatile memory as 25 °C reference data.

Note :

1. Usually, do not perform this adjustment.
2. Perform this adjustment in an ambient temperature of 22 °C to 28 °C. Perform it immediately after the power is turned on when the internal temperature of the unit is the same as the ambient temperature of 22 °C to 28 °C.
3. When D101 has been replaced, perform this adjustment after the temperature of this part has become the ambient temperature.

Adjusting Procedure :

1. Press the \lll or \ggg button to display "TEMP ADJUST".
2. Press the ENTER/YES "R" button to select the "TEMP ADJUST" mode.
3. "TEMP = [] [OK]" and the current temperature data will be displayed.
4. To save the data, press the ENTER/YES "R" button.
When not saving the data, press the MENU/NO "R" button.
5. When the ENTER/YES "R" button is pressed, "TEMP = [] SAVE" will be displayed and turned back to "TEMP ADJUST" display then. When the MENU/NO "R" button is pressed, "TEMP ADJUST" will be displayed immediately.

Specified Value :

The "TEMP = []" should be within "E0 - EF", "F0 - FF", "00 - 0F", "10 - 1F" and "20 - 2F".

5-10. LASER POWER ADJUSTMENT

Check the IOP value of the optical pick-up before adjustments. (Refer to 8. Recording and Displaying IOP Information)

Connection :

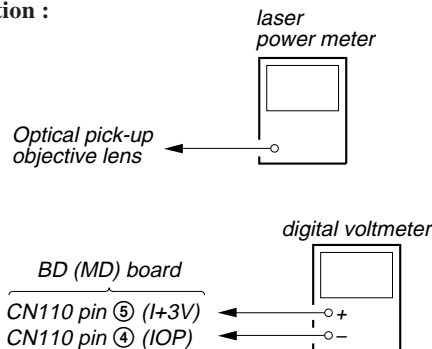

Adjusting Procedure :

1. Set the laser power meter on the objective lens of the optical pick-up. (When it cannot be set properly, press the \lll or \ggg button to move the optical pick-up)
Connect the digital voltmeter to CN110 pin 5 (I+3V) and CN110 pin 4 (IOP) on the BD (MD) board.
 2. Press the \lll or \ggg button to display "LDPWR ADJUST".
(Laser power : For adjustment)
 3. Press the ENTER/YES "R" button once to display "LD 0.9 mW \$ []".
 4. Press the \lll or \ggg button so that the reading of the laser power meter becomes 0.85 to 0.91 mW. Press the ENTER/YES "R" button after setting the range knob of the laser power meter, and save the adjustment results. ("LD SAVE \$ []" will be displayed for a moment)
 5. Then "LD 7.0 mW \$ []" will be displayed.
 6. Press the \lll or \ggg button so that the reading of the laser power meter becomes 6.9 to 7.1 mW, press the ENTER/YES "R" button to save it.
- Note:** Do not perform the emission with 7.0 mW more than 15 seconds continuously.
7. Then, press the \lll or \ggg button to display "LDPWR CHECK".
 8. Press the ENTER/YES "R" button once to display "LD 0.9 mW \$ []". Check that the reading of the laser power meter become 0.85 to 0.91 mW.
 9. Press the ENTER/YES "R" button once more to display "LD 7.0 mW \$ []". Check that the reading the laser power meter and digital voltmeter satisfy the specified value.
Note down the digital voltmeter reading value.

Specified Value:

Laser power meter reading: 7.0 ± 0.2 mW

Digital voltmeter reading : Value on the optical pick-up label $\pm 10\%$

(Optical pick-up label)

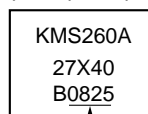

IOP=82.5 mA in this case

$IOP (mA) = \text{Digital voltmeter reading (mV)} / 1 (\Omega)$

10. Press the MENU/NO "R" button to display "LDPWR CHECK" and stop the laser emission.
(The MENU/NO "R" button is effective at all times to stop the laser emission.)
11. Press the \lll or \ggg button to display "Iop Write".

12. Press the **[ENTER/YES "R"]** button. When the display becomes Ref=@@.@ (@ is an arbitrary number), press the **[ENTER/YES "R"]** button to display "Measu=@@.@." (@ is an arbitrary number).
13. The numbers which can be changed will blink. Input the Iop value noted down at step 9.
To select the number : Press the **[<<<<]** or **[>>>>]** button.
To select the digit : Press the **[SYNC REC]** button.
14. When the **[ENTER/YES "R"]** button is pressed, "Complete!" will be displayed momentarily. The value will be recorded in the non-volatile memory and the display will become "Top Write".

Note 1: After step 4, each time the **[ENTER/YES "R"]** button is pressed, the display will be switched "LD 0.7 mW \$ []", "LD 6.2 mW \$ []", and "LD Wp ホセイ \$ []". Nothing needs to be performed here.

5-11. TRAVERSE ADJUSTMENT

Note 1:Data will be erased during MO reading if a recorded disc is used in this adjustment.

Note 2:If the traverse waveform is not clear, connect the oscilloscope as shown in the following figure so that it can be seen more clearly.

Connection :

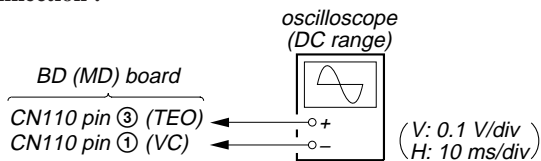

Adjusting Procedure :

1. Connect an oscilloscope to CN110 pin ③ (TEO) and CN110 pin ① (VC) on the BD (MD) board.
2. Load a disc (any available on the market). (Refer to Note 1)
3. Press the **[>>>>]** button to move the optical pick-up outside the pit.
4. Press the **[<<<<]** or **[>>>>]** button to display "EF MO ADJUST".
5. Press the **[ENTER/YES "R"]** button to display "EFB = [] MO-R". (Laser power READ power/Focus servo ON/tracking servo OFF/spindle (S) servo ON)
6. Press the **[<<<<]** or **[>>>>]** button so that the waveform of the oscilloscope becomes the specified value.
(When the **[<<<<]** or **[>>>>]** button is pressed, the [] of "EFB = []" changes and the waveform changes) In this adjustment, waveform varies at intervals of approx. 2%. Adjust the waveform so that the specified value is satisfied as much as possible.
(Read power traverse adjustment)

Traverse Waveform

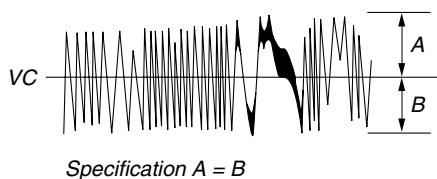

7. Press the **[ENTER/YES "R"]** button and save the result of adjustment to the non-volatile memory ("EFB = [] SAVE" will be displayed for a moment. Then "EFB = [] MO-W" will be displayed).
8. Press the **[<<<<]** or **[>>>>]** button so that the waveform of the oscilloscope becomes the specified value.
(When the **[<<<<]** or **[>>>>]** button is pressed, the [] of "EFB = []" changes and the waveform changes) In this adjustment, waveform varies at intervals of approx. 2%. Adjust the waveform so that the specified value is satisfied as much as possible.
(Write power traverse adjustment)

Traverse Waveform

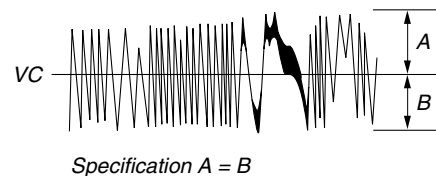

9. Press the **[ENTER/YES "R"]** button, and save the adjustment results in the non-volatile memory. ("EFB = [] SAVE" will be displayed for a moment)
10. "EFB = [] MO-P" will be displayed.
The optical pick-up moves to the pit area automatically and servo is imposed.
11. Press the **[<<<<]** or **[>>>>]** button until the waveform of the oscilloscope moves closer to the specified value.
In this adjustment, waveform varies at intervals of approx. 2%. Adjust the waveform so that the specified value is satisfied as much as possible.

Traverse Waveform

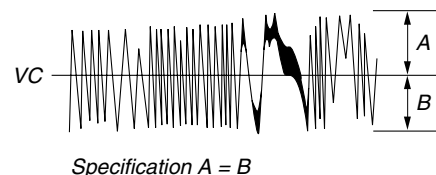

12. Press the **[ENTER/YES "R"]** button, and save the adjustment results in the non-volatile memory. ("EFB = [] SAVE" will be displayed for a moment)
Next "EF MO ADJUST" is displayed. The disc stops rotating automatically.
13. Press the **[MD]** button and take out the disc.
14. Load the check disc (MD) TDYS-1.
15. Press the **[<<<<]** or **[>>>>]** button to display "EF CD ADJUST".
16. Press the **[ENTER/YES "R"]** button to display "EFB = [] CD".
Servo is imposed automatically.
17. Press the **[<<<<]** or **[>>>>]** button so that the waveform of the oscilloscope moves closer to the specified value.
In this adjustment, waveform varies at intervals of approx. 2%. Adjust the waveform so that the specified value is satisfied as much as possible.

Traverse Waveform

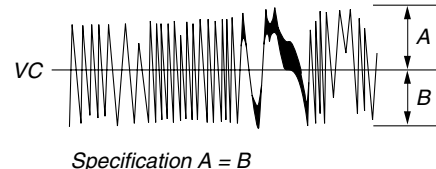

18. Press the **[ENTER/YES "R"]** button, display "EFB = **000** SAVE" for a moment and save the adjustment results in the non-volatile memory. Next "EF CD ADJUST" will be displayed.
19. Press the **[MD]** (MD) button and take out the disc.

5-12. FOCUS BIAS ADJUSTMENT

Adjusting Procedure :

1. Load the continuously-recorded disc. (Refer to "5-5. CREATING CONTINUOUSLY-RECORDED DISC")
2. Press the **[<<< <<<]** or **[>>> >>>]** button to display "CPLAY MODE".
3. Press the **[ENTER/YES "R"]** button to display "CPLAY MID".
4. Press the **[MENU/NO "R"]** button when "C1 = **0000** AD = **00**" is displayed.
5. Press the **[<<< <<<]** or **[>>> >>>]** button to display "FBIAS ADJUST".
6. Press the **[ENTER/YES "R"]** button to display "**0000**/a = **00**". The first four digits indicate the C1 error rate, the two digits after [/] indicate ADER, and the 2 digits after [a =] indicate the focus bias value.
7. Press the **[>>> >>>]** button and find the focus bias value at which the C1 error rate becomes about 200 (Refer to Note 2).
8. Press the **[ENTER/YES "R"]** button to display "**0000**/b = **00**".
9. Press the **[<<< <<<]** button and find the focus bias value at which the C1 error rate becomes about 200.
10. Press the **[ENTER/YES "R"]** button to display "**0000**/c = **00**".
11. Check that the C1 error rate is below 50 and ADER is 00. Then press the **[ENTER/YES "R"]** button.
12. If the "(00)" in "00 - 00 - 00 (00)" is above 20, press the **[ENTER/YES "R"]** button.
If below 20, press the **[MENU/NO "R"]** button and repeat the adjustment from step 2.
13. Press the **[MD]** (MD) button and take out the disc.

Note 1: The relation between the C1 error and focus bias is as shown in the following figure. Find points A and B in the following figure using the above adjustment. The focal point position C is automatically calculated from points A and B.

Note 2: As the C1 error rate changes, perform the adjustment using the average value.

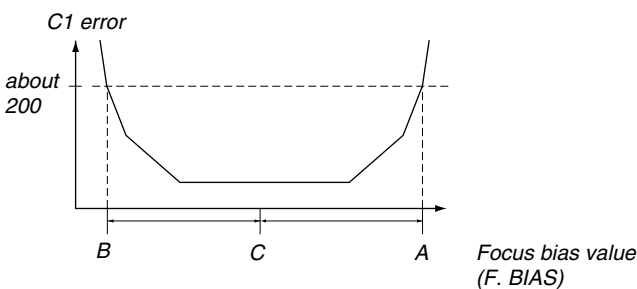

5-13. ERROR RATE CHECK

5-13-1. CD Error Rate Check

Checking Procedure :

1. Load the check disc (MD) TDYS-1.
2. Press the **[<<< <<<]** or **[>>> >>>]** button and display "CPLAY MODE".
3. Press the **[ENTER/YES "R"]** button twice and display "CPLAY MID".
4. The display changes to "C1 = **0000** AD = **00**".
5. Check that the C1 error rate is below 20.
6. Press the **[MENU/NO "R"]** button to stop playback, then press the **[MD]** (MD) button and take out the check disc.

5-13-2. MO Error Rate Check

Checking Procedure :

1. Load the continuously-recorded disc. (Refer to "5-5. CREATING CONTINUOUSLY-RECORDED DISC")
2. Press the **[<<< <<<]** or **[>>> >>>]** button to display "CPLAY MODE".
3. Press the **[ENTER/YES "R"]** button to display "CPLAY MID".
4. The display changes to "C1 = **0000** AD = **00**".
5. If the C1 error rate is below 50, check that ADER is below 2.
6. Press the **[MENU/NO "R"]** button to stop playback, then press the **[MD]** (MD) button and take out the test disc.

5-14. FOCUS BIAS CHECK

Change the focus bias and check the focus tolerance amount.

Checking Procedure :

1. Load the continuously-recorded disc. (Refer to "5-5. CREATING CONTINUOUSLY-RECORDED DISC")
2. Press the **[<<< <<<]** or **[>>> >>>]** button to display "CPLAY MODE".
3. Press the **[ENTER/YES "R"]** button twice to display "CPLAY MID".
4. Press the **[MENU/NO "R"]** button when "C1 = **0000** AD = **00**" is displayed.
5. Press the **[<<< <<<]** or **[>>> >>>]** button to display "FBIAS CHECK".
6. Press the **[ENTER/YES "R"]** button to display "**0000**/c = **00**". The first four digits indicate the C1 error rate, the two digits after [/] indicate ADER, and the 2 digits after [c =] indicate the focus bias value.
Check that the C1 error is below 50 and ADER is below 2.
7. Press the **[ENTER/YES "R"]** button and display "**0000**/b = **00**".
Check that the C1 error is about 200 and ADER is below 2.
8. Press the **[ENTER/YES "R"]** button and display "**0000**/a = **00**".
Check that the C1 error is about 200 and ADER is below 2.
9. Press the **[MENU/NO "R"]** button, then press the **[MD]** (MD) button and take out the disc.

Note 1: If the C1 error and ADER are above other than the specified value at points A (step 8. in the above) or B (step 7. in the above), the focus bias adjustment may not have been carried out properly. Adjust perform the beginning again.

5-15. AUTO GAIN CONTROL OUTPUT LEVEL ADJUSTMENT

Be sure to perform this adjustment when the optical pick-up is replaced.

If the adjustment results becomes "Adjust NG!", the optical pick-up may be faulty or the servo system circuits may be abnormal.

5-15-1. CD Auto Gain Control Output Level Adjustment

Adjusting Procedure :

1. Load the check disc (MD) TDYS-1.
2. Press the **[<<< <<<]** or **[>>> >>>]** button to display "AG Set (CD)".
3. When the **[ENTER/YES "R"]** button is pressed, the adjustment will be performed automatically. "Complete!!" will then be displayed momentarily when the value is recorded in the non-volatile memory, after which the display changes to "AG Set (CD)".
4. Press the **[MD]** (MD) button and take out the check disc.

**5-15-2. MO Auto Gain Control Output Level Adjustment
Adjusting Procedure :**

1. Load the test disc (MDW-74/AU-1).
2. Press the [◀◀ ◀◀] or [▶▶ ▶▶] button to display “AG Set (MO)”.
3. When the [ENTER/YES “R”] button is pressed, the adjustment will be performed automatically.
“Complete!!” will then be displayed momentarily when the value is recorded in the non-volatile memory, after which the display changes to “AG Set (MO)”.
4. Press the [MD] button and take out the test disc.

Adjustment Location:

– BD (MD) BOARD (Side A) –

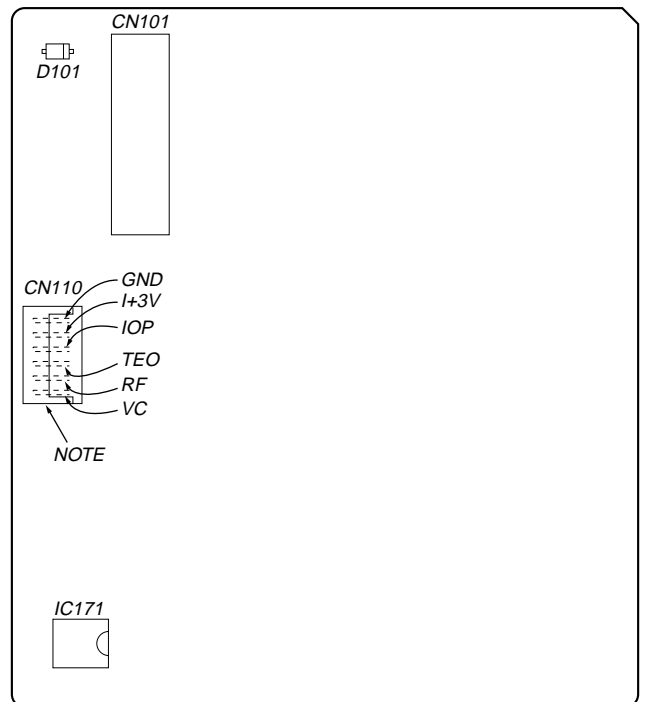

– BD (MD) BOARD (Side B) –

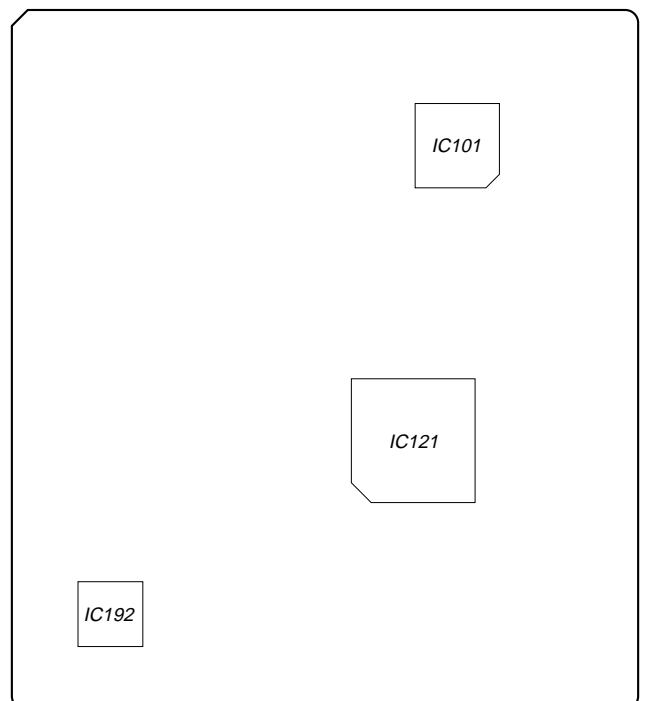

Note: It is useful to use the jig for checking BD (MD) board waveform.
(Refer to Servicing Notes on page 9)

CD SECTION

Note :

1. CD Block is basically designed to operate without adjustment. Therefore, check each item in order given.
2. Use YEDS-18 disc (3-702-101-01) unless otherwise indicated.
3. Use an oscilloscope with more than 10 MΩ impedance.
4. Clean the object lens by an applicator with neutral detergent when the signal level is low than specified value with the following checks.

S-Curve Check

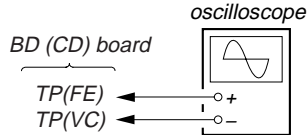

Procedure :

1. Connect an oscilloscope to TP (FE) and TP (VC).
2. Connect between TP (FE1) and TP (GND) by lead wire.
3. Connect between TP (AGCCON) and TP (GND) by lead wire.
4. Press the button to turn the power on.
5. Load a disc (YEDS-18) and press the (CD) button to actuate the focus search. (In consequence of open and close the disc tray, actuate the focus search)
6. Confirm that the oscilloscope waveform (S-curve) is symmetrical between A and B. And confirm peak to peak level within 4 ± 1 Vp-p.

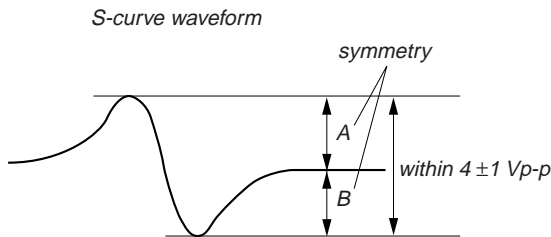

7. After check, remove the lead wire connected in step 2 and 3.

Note :

- Try to measure several times to make sure than the ratio of A : B or B : A is more than 10 : 7.
- Take sweep time as long as possible and light up the brightness to obtain best waveform.

RF Level Check

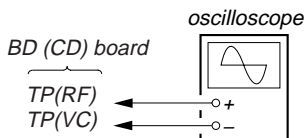

Procedure :

1. Connect an oscilloscope to TP (RF) and TP (VC).
2. Connect between TP (AGCCON) and TP (GND) by lead wire.
3. Press the button to turn the power on.
4. Load a disc (YEDS-18) and playback the number five track.
5. Confirm that the oscilloscope waveform is clear and check RF signal level is correct or not.
6. After check, remove the lead wire connected in step 2.

Note: Clear RF signal waveform means that the shape “◊” can be clearly distinguished at the center of the waveform.

RF signal waveform

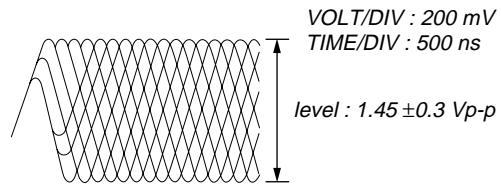

E-F Balance (1 Track Jump) Check

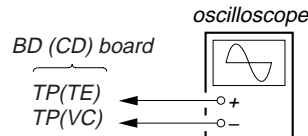

Procedure:

1. Connect an oscilloscope to TP (TE) and TP (VC) board.
2. Press the button to turn the power on.
3. Load a disc (YEDS-18) and playback the number five track.
4. Press the (CD) button. (Becomes the 1 track jump mode.)
5. Confirm that the level B and A (DC voltage) on the oscilloscope waveform.

1 track jump waveform

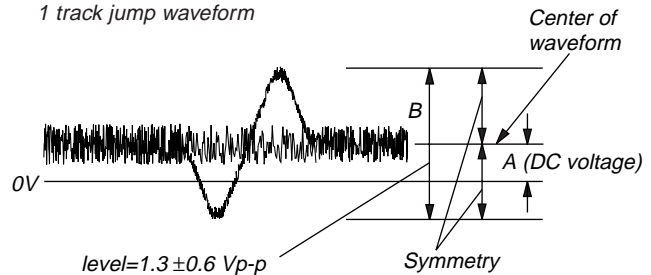

Specification level: $\frac{A}{B} \times 100 = \text{less than } \pm 22\%$

6. After check, remove the lead wire connected in step 1.

Adjustment Location:

– BD (CD) BOARD (Conductor Side) –

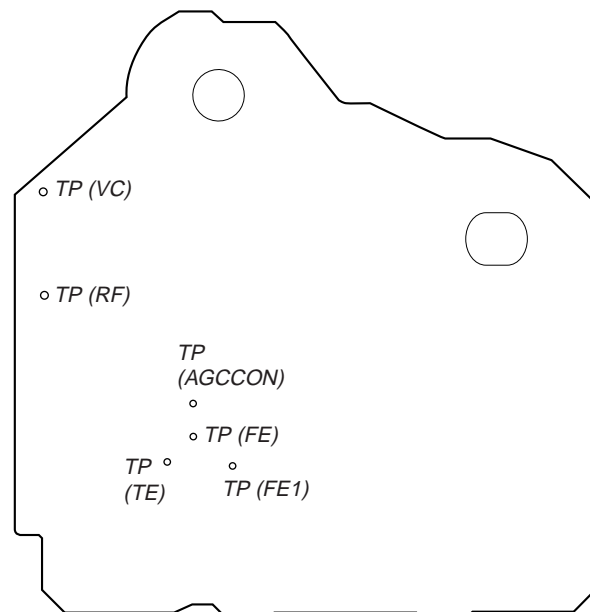

SECTION 6
DIAGRAMS

6-1. BLOCK DIAGRAM – CD SERVO Section –

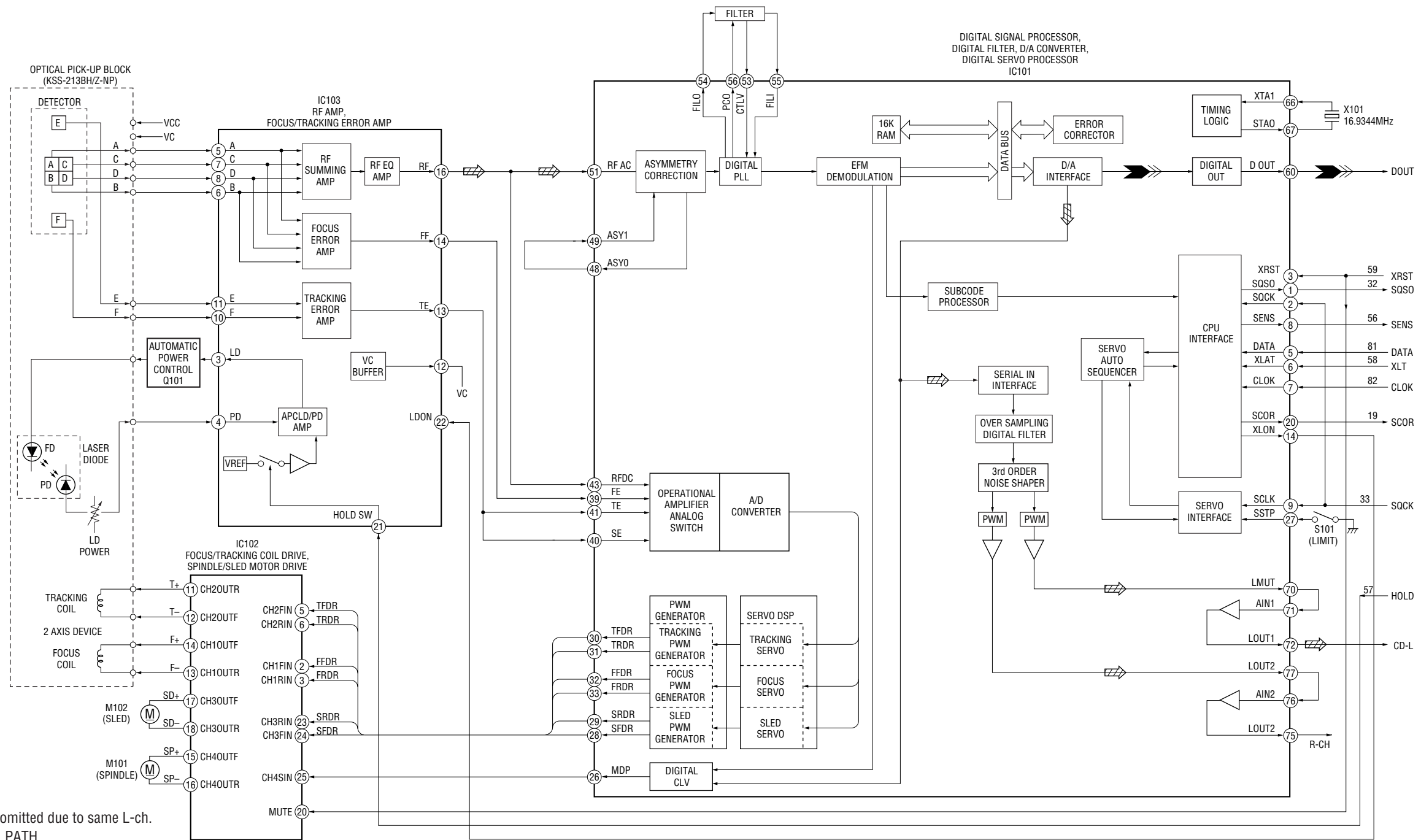

- R-ch is omitted due to same L-ch.
- SIGNAL PATH
 - ▬ : CD PLAY
 - ▬▬▬ : MD REC (DIGITAL)

(Page 40)
A
BD (MD)
SECTION
(1/2)

B
MAIN
SECTION
(Page 42)

C
MAIN
SECTION
(Page 42)

6-2. BLOCK DIAGRAM - MD SERVO Section (1/2) -

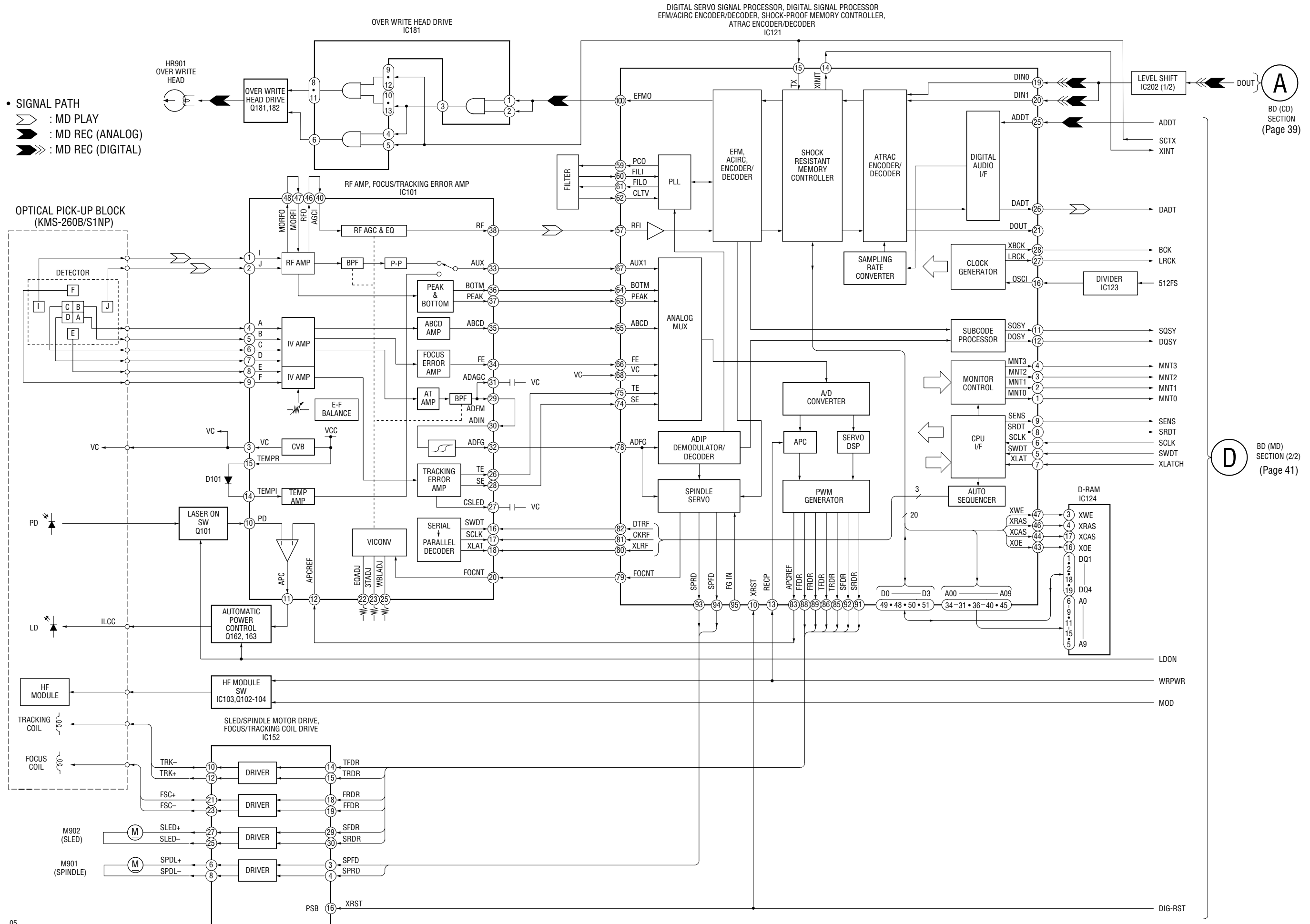

6-3. BLOCK DIAGRAM – MD SERVO Section (2/2) –

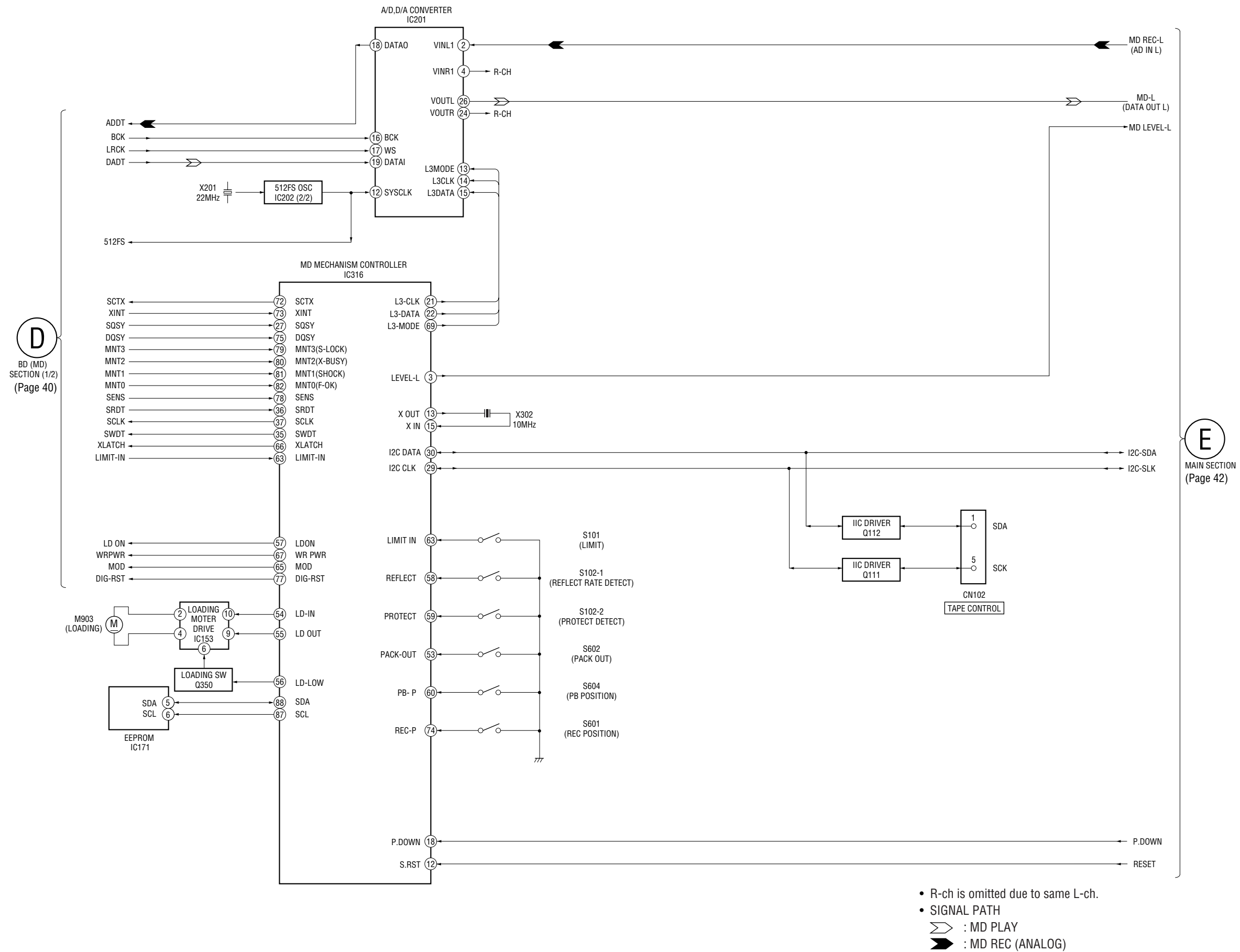

6-4. BLOCK DIAGRAM – MAIN Section –

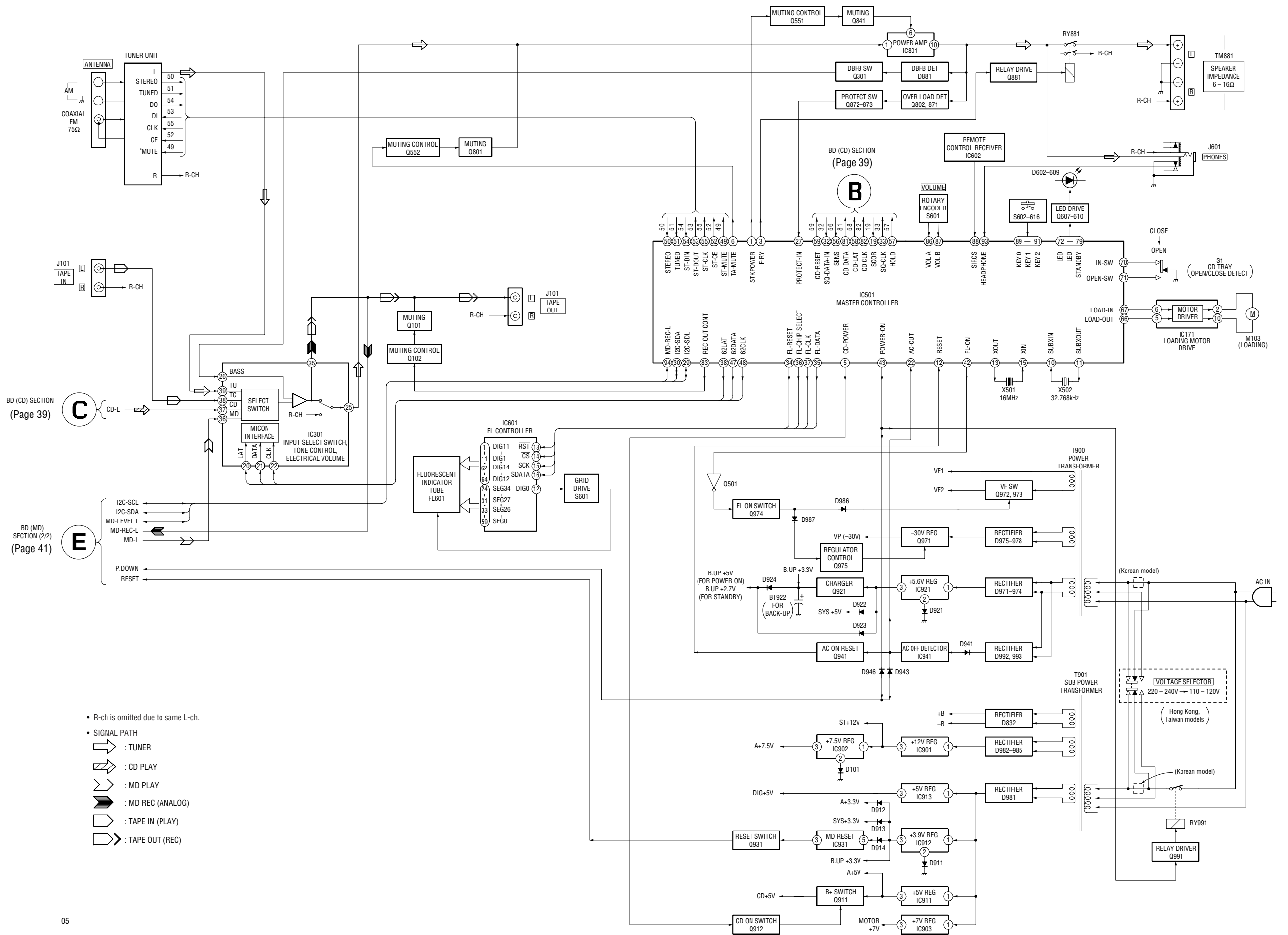

- R-ch is omitted due to same L-ch.
- SIGNAL PATH
 - ➡ : TUNER
 - ➡ : CD PLAY
 - ➡ : MD PLAY
 - ➡ : MD REC (ANALOG)
 - ➡ : TAPE IN (PLAY)
 - ➡ : TAPE OUT (REC)

• Circuit Boards Location

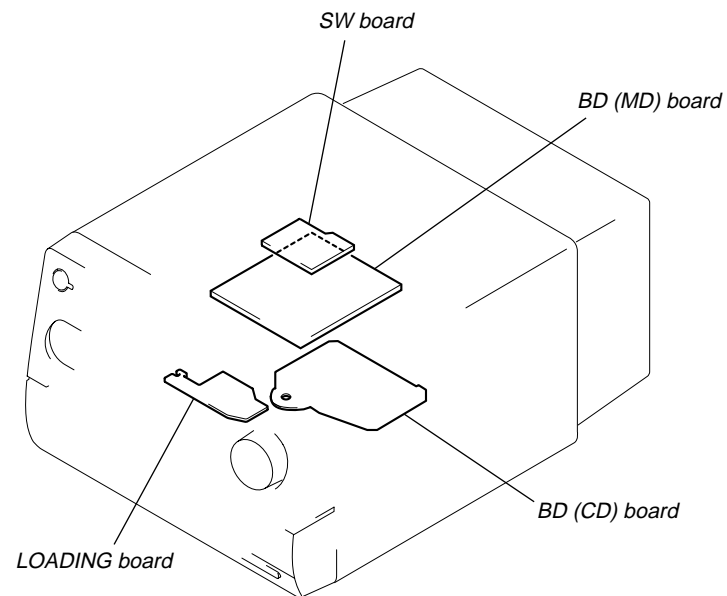
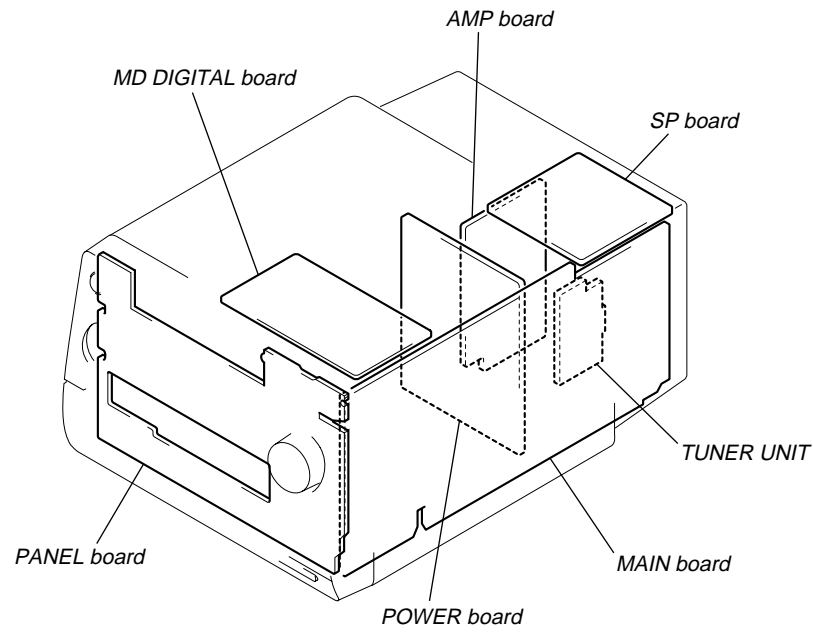

6-5. NOTE FOR PRINTED WIRING BOARDS AND SCHEMATIC DIAGRAMS
(In addition to this, the necessary note is printed in each block)

Note on Printed Wiring Boards:

- : parts extracted from the component side.
- : parts extracted from the conductor side.
- : Pattern from the side which enables seeing.
(The other layers' patterns are not indicated.)

Caution:
 Pattern face side: Parts on the pattern face side seen from the pattern face are indicated.
 Parts face side: Parts on the parts face side seen from the parts face are indicated.

- Indication of transistor.

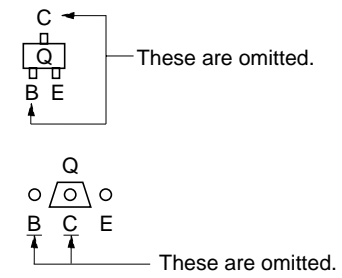

Note on Schematic Diagram:

- All capacitors are in μF unless otherwise noted. pF : μpF 50 WV or less are not indicated except for electrolytics and tantalums.
- All resistors are in Ω and $1/4\text{W}$ or less unless otherwise specified.
- : internal component.
- : nonflammable resistor.
- : fusible resistor.
- : panel designation.

Note: The components identified by mark Δ or dotted line with mark Δ are critical for safety. Replace only with part number specified.

- : B+ Line.
- : B- Line.
- Voltages are taken with a VOM (Input impedance 10 M Ω). Voltage variations may be noted due to normal production tolerances.
- Waveforms are taken with a oscilloscope. Voltage variations may be noted due to normal production tolerances.
- Circled numbers refer to waveforms.
- Signal path.
 - : TUNER
 - : CD PLAY
 - : MD PLAY
 - : MD REC (ANALOG)
 - : MD REC (DIGITAL)
 - : TAPE IN (PLAY)
 - : TAPE OUT (REC)
- Abbreviation
 - HK : Hong Kong model
 - KR : Korean model
 - TW : Taiwan model

6-6. PRINTED WIRING BOARD – BD (CD) Board – • See page 43 for Circuit Boards Location.

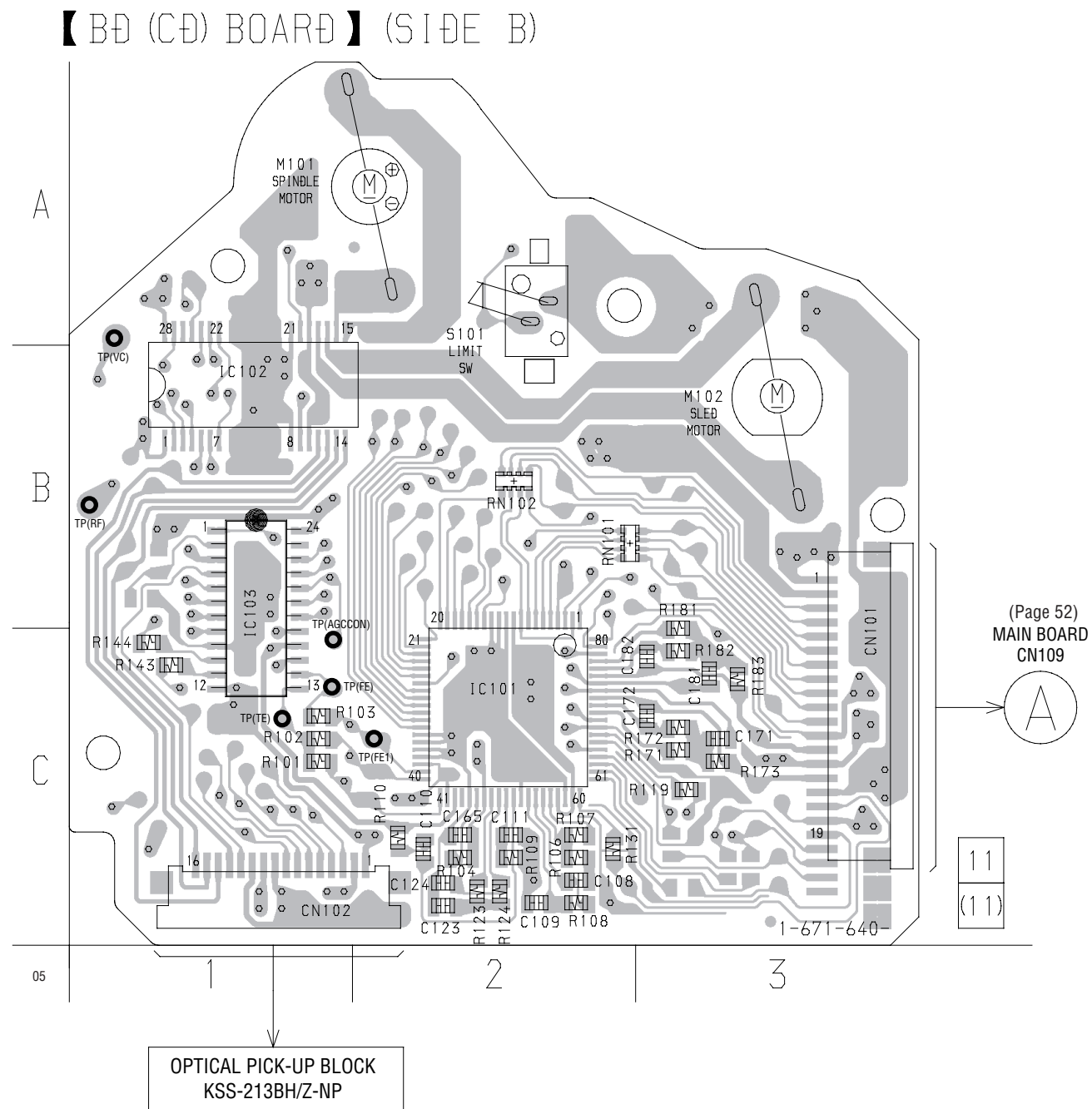
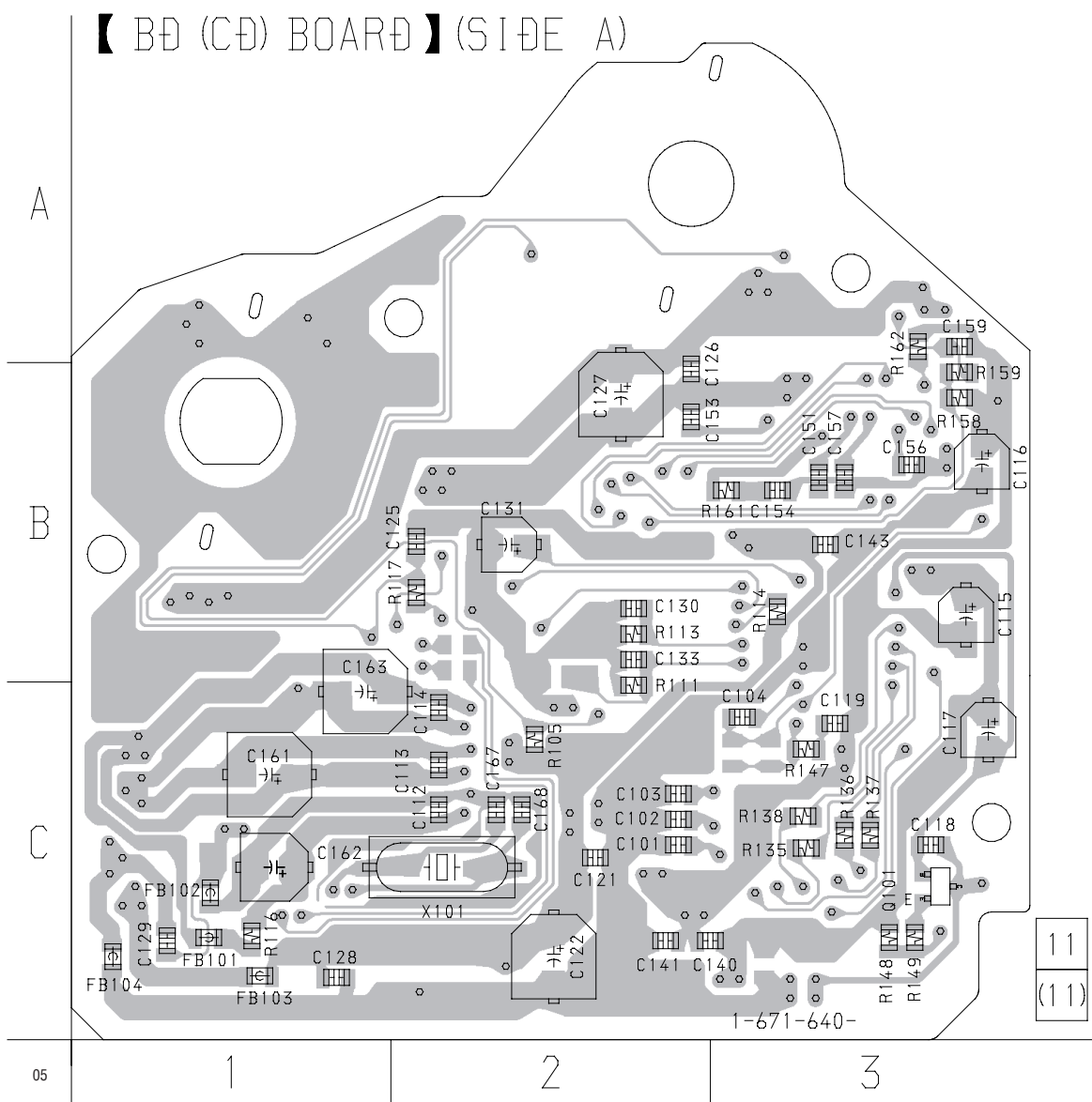

6-7. SCHEMATIC DIAGRAM – BD (CD) Board – • See page 62 for waveforms. • See page 63 for IC Block Diagrams.

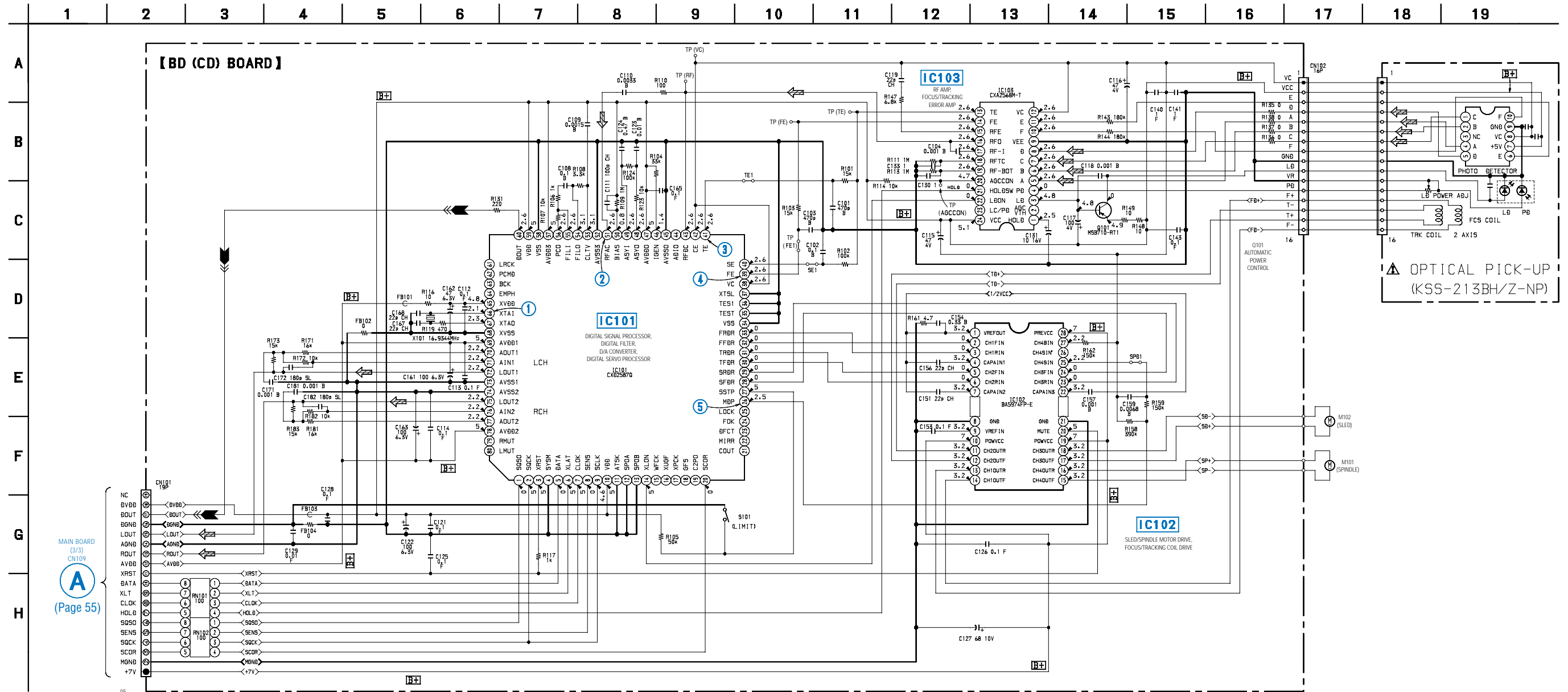

• Voltages and waveforms are dc with respect to ground under no-signal conditions.
no mark : CD PLAY

The components identified by mark ▲ or dotted line with mark ▲ are critical for safety. Replace only with part number specified.

6-8. SCHEMATIC DIAGRAM – BD (MD) Board (1/2) – • See page 62 for waveforms. • See page 63 for IC Block Diagrams.

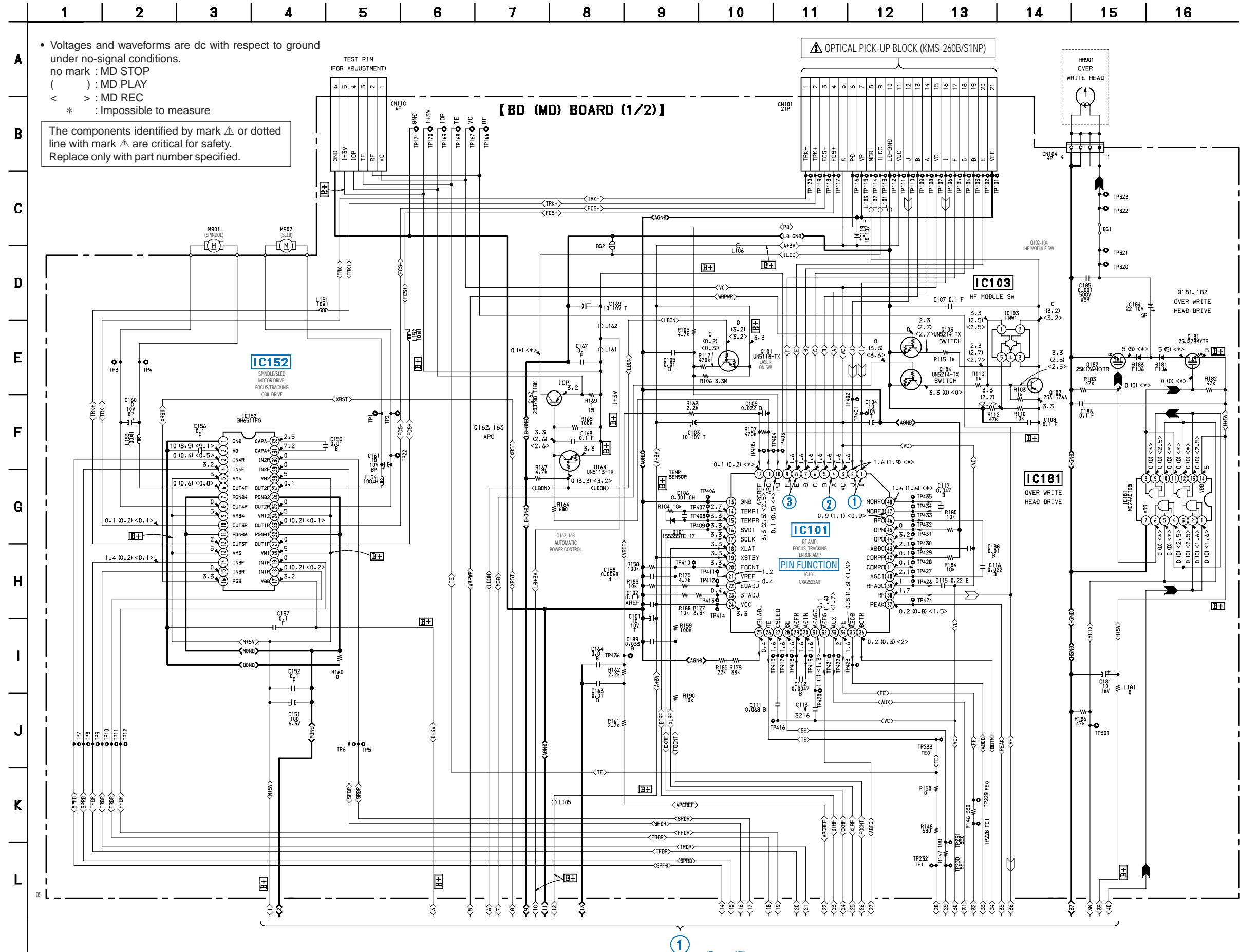

6-9. SCHEMATIC DIAGRAM – BD (MD) Board (2/2) – • See page 62 for waveforms. • See page 63 for IC Block Diagrams.

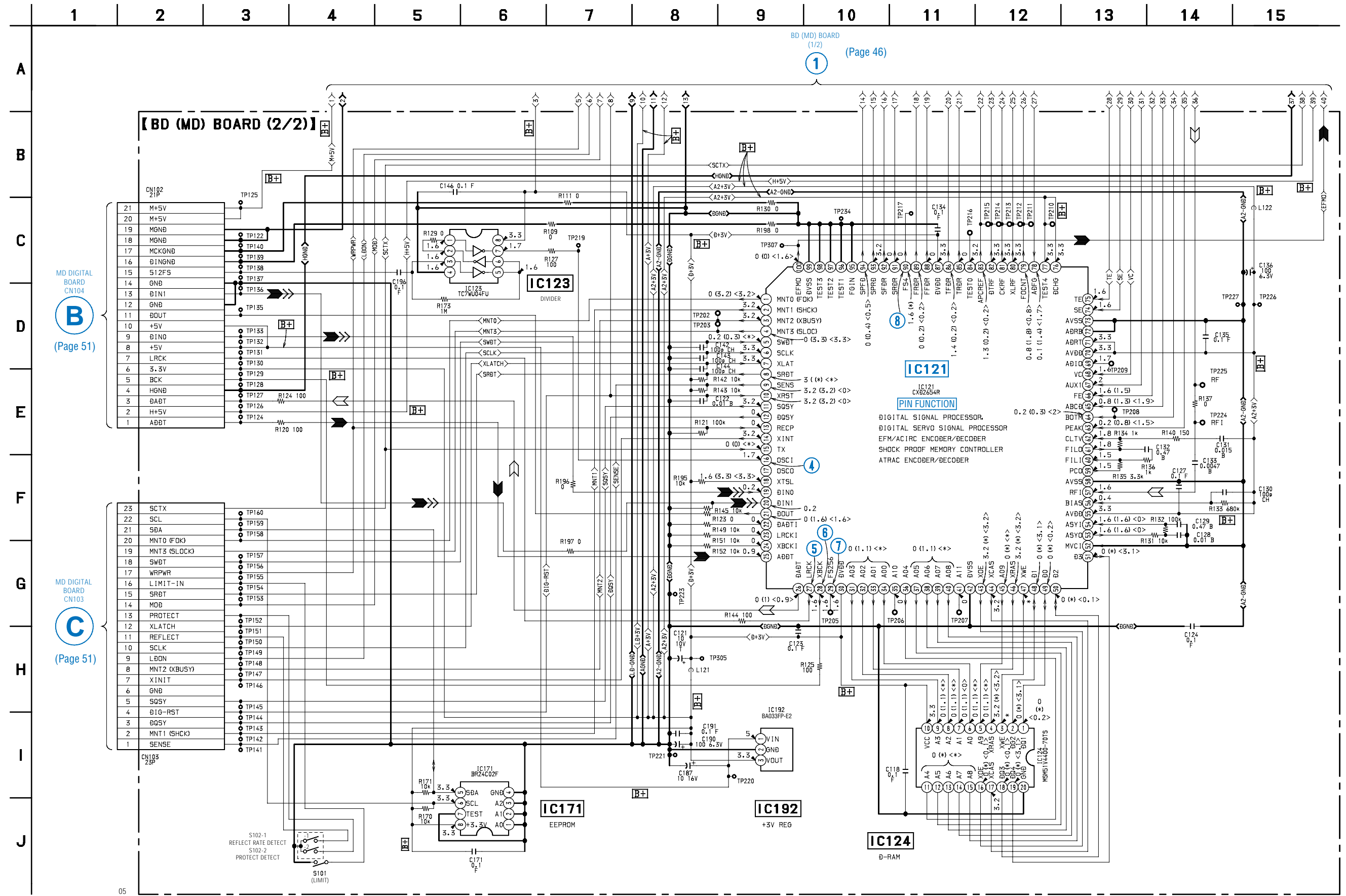

• Voltages and waveforms are dc with respect to ground under no-signal conditions.
 no mark : MD STOP
 () : MD PLAY
 < > : MD REC
 * : Impossible to measure

6-10. PRINTED WIRING BOARD – BD (MD) Board – • See page 43 for Circuit Boards Location.

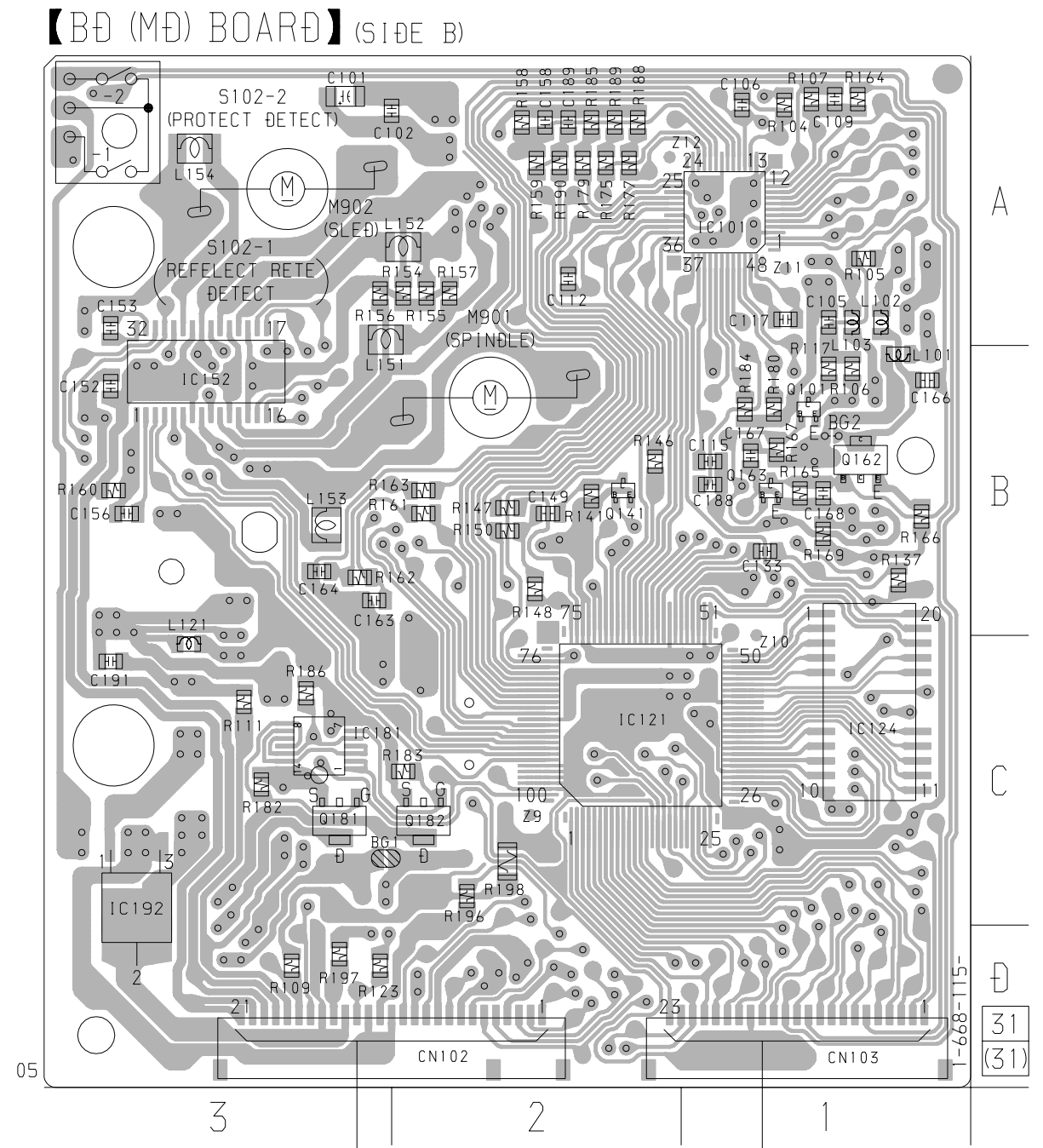
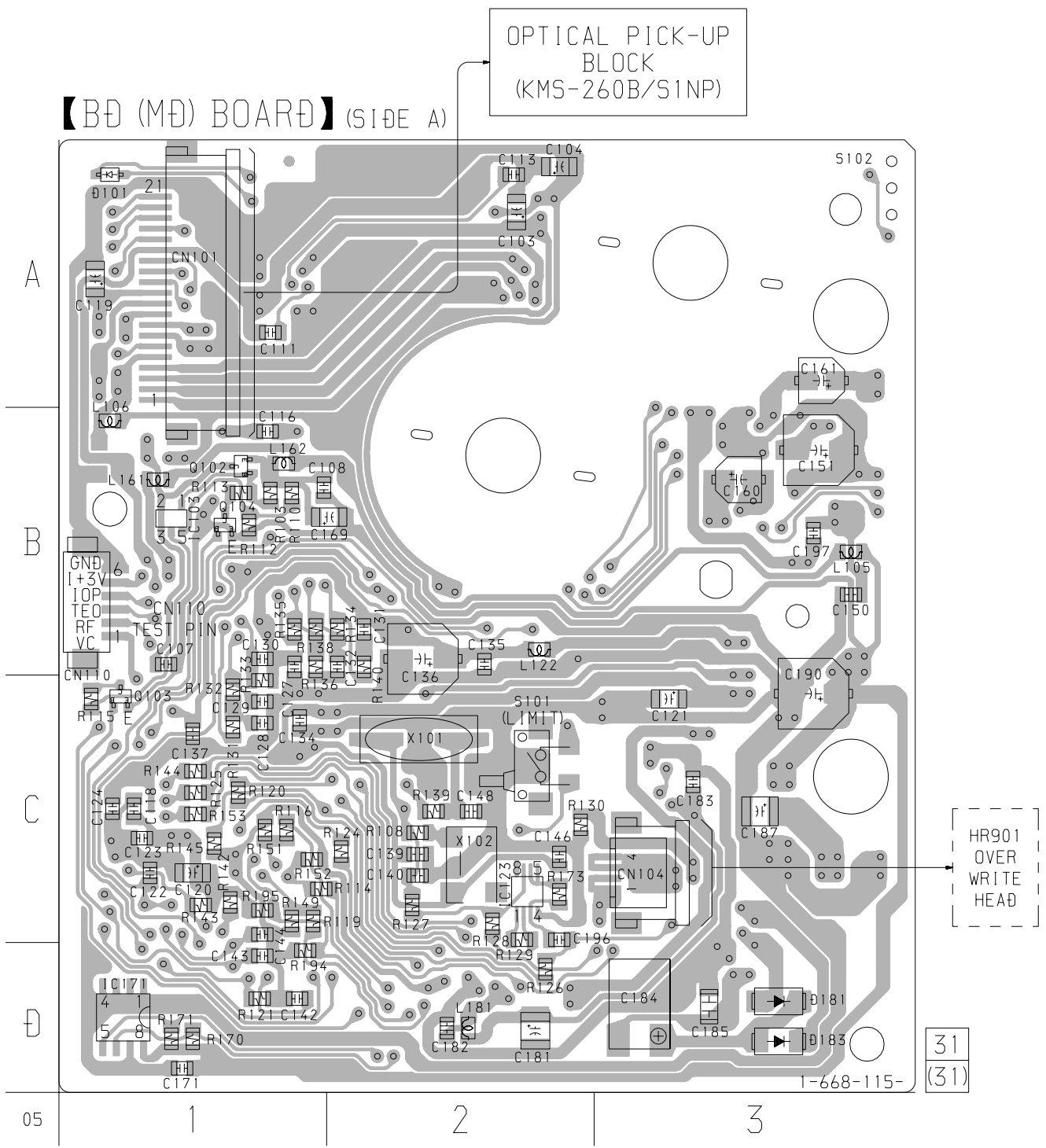

• Semiconductor Location

Ref. No.	Location
D101	A-1
D181	D-3
D183	D-3
IC103	B-1
IC123	C-2
IC171	D-1
Q102	B-1
Q103	C-1
Q104	B-1

• Semiconductor Location

Ref. No.	Location
IC101	A-1
IC121	C-2
IC124	C-1
IC152	B-3
IC181	C-3
IC192	C-3
Q101	B-1
Q162	B-1
Q163	B-1
Q181	C-2
Q182	C-2

There are a few cases that the part isn't mounted in model is printed on diagrams.

6-11. SCHEMATIC DIAGRAM – BD SW (MD) Board –

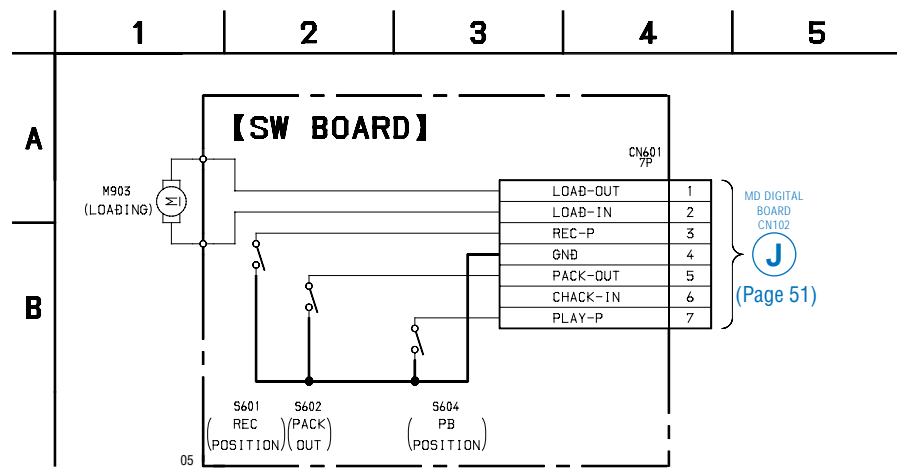

6-13. SCHEMATIC DIAGRAM – LOADING (CD) Board –

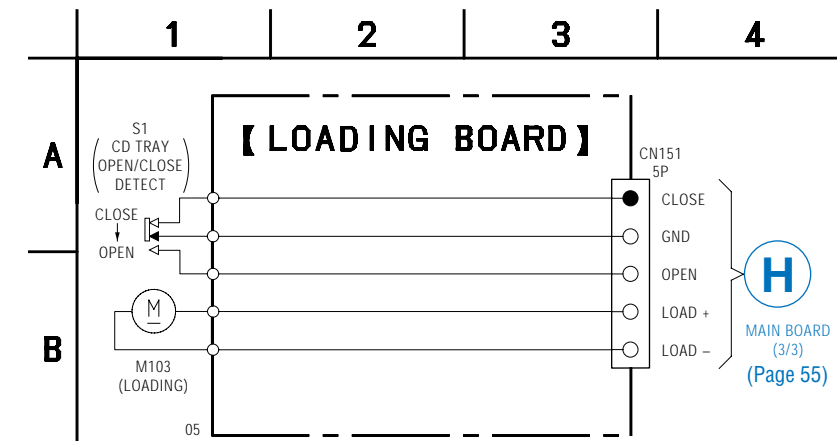

6-12. PRINTED WIRING BOARD – BD SW (MD) Board – • See page 43 for Circuit Boards Location.

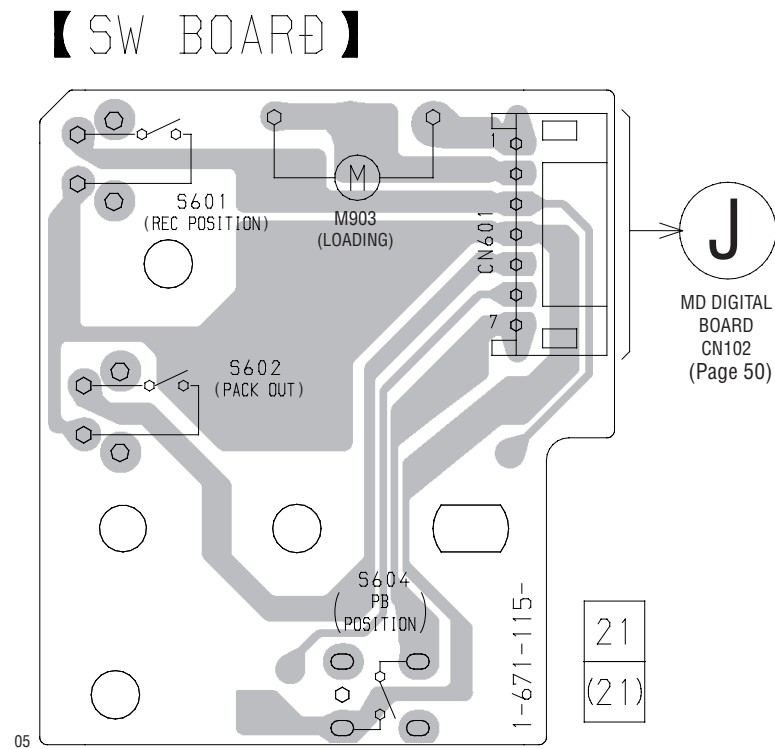

6-14. PRINTED WIRING BOARD – LOADING (CD) Board – • See page 43 for Circuit Boards Location.

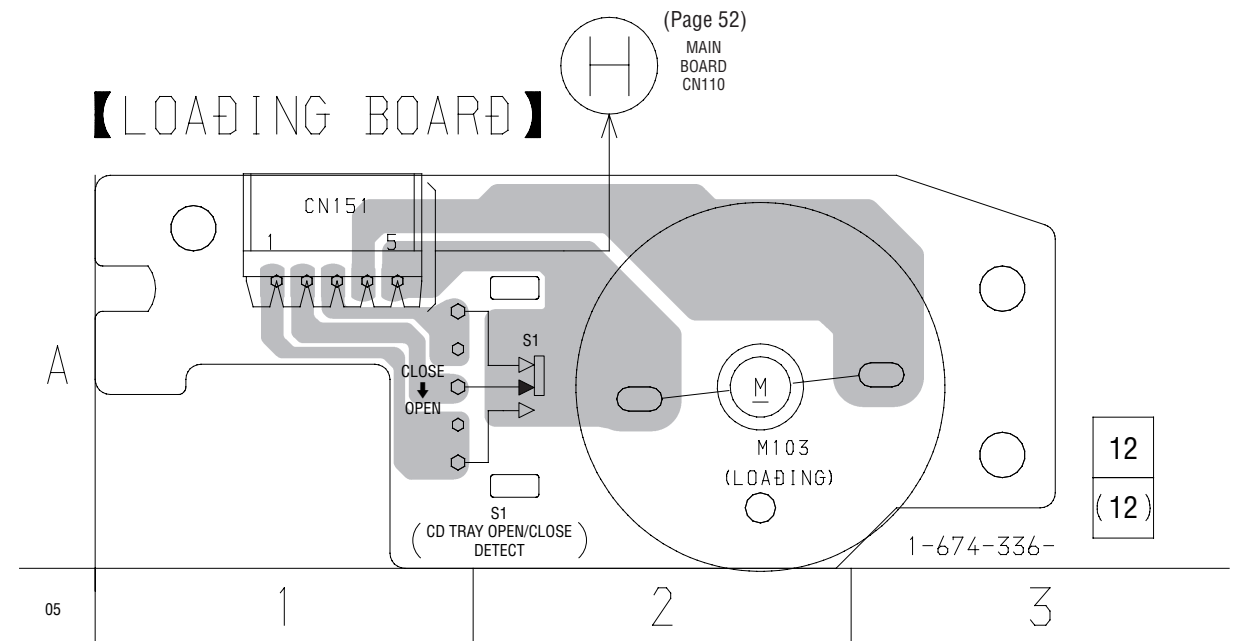

【 MD DIGITAL BOARD 】 (SIDE A)

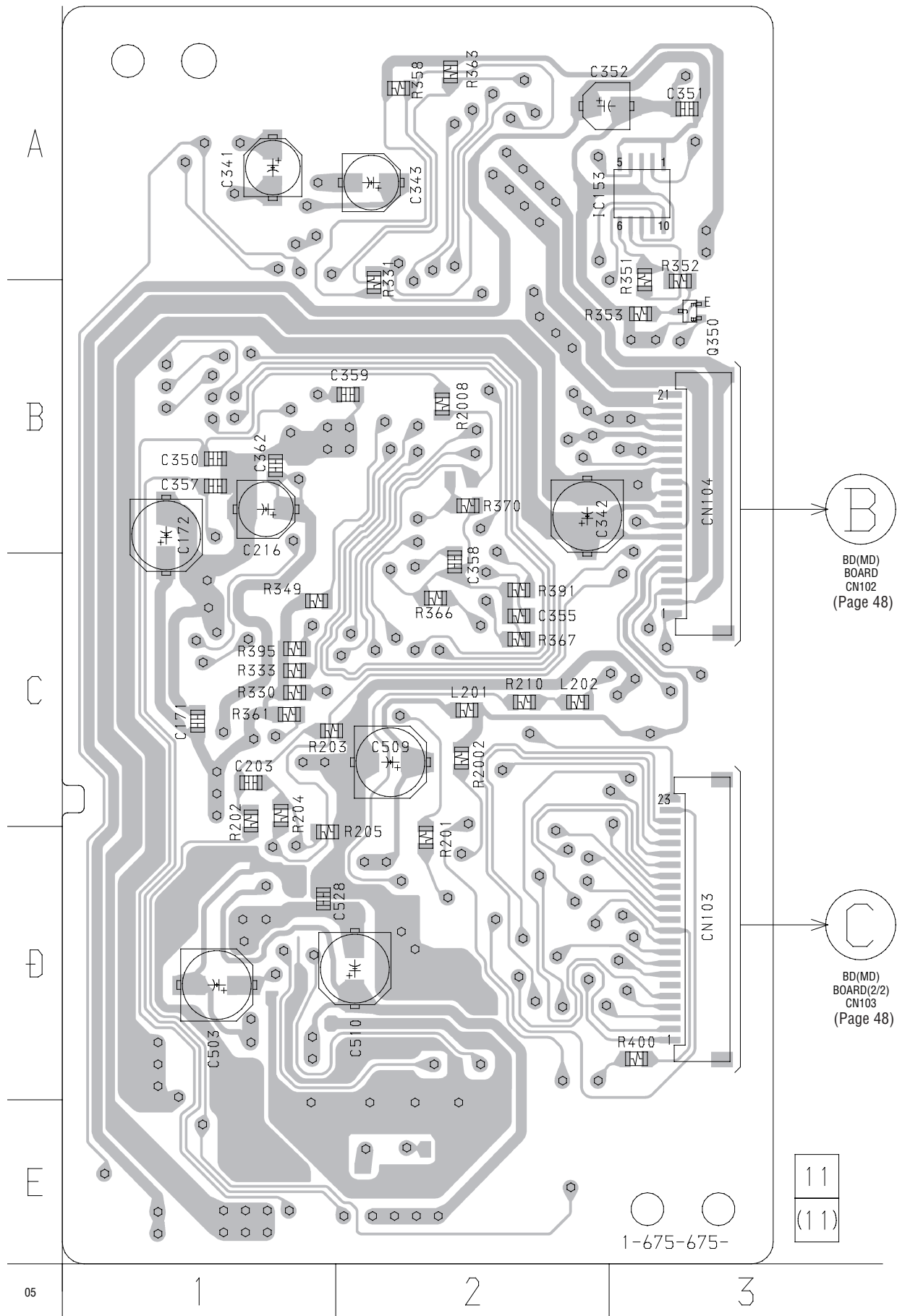

【 MD DIGITAL BOARD 】 (SIDE B)

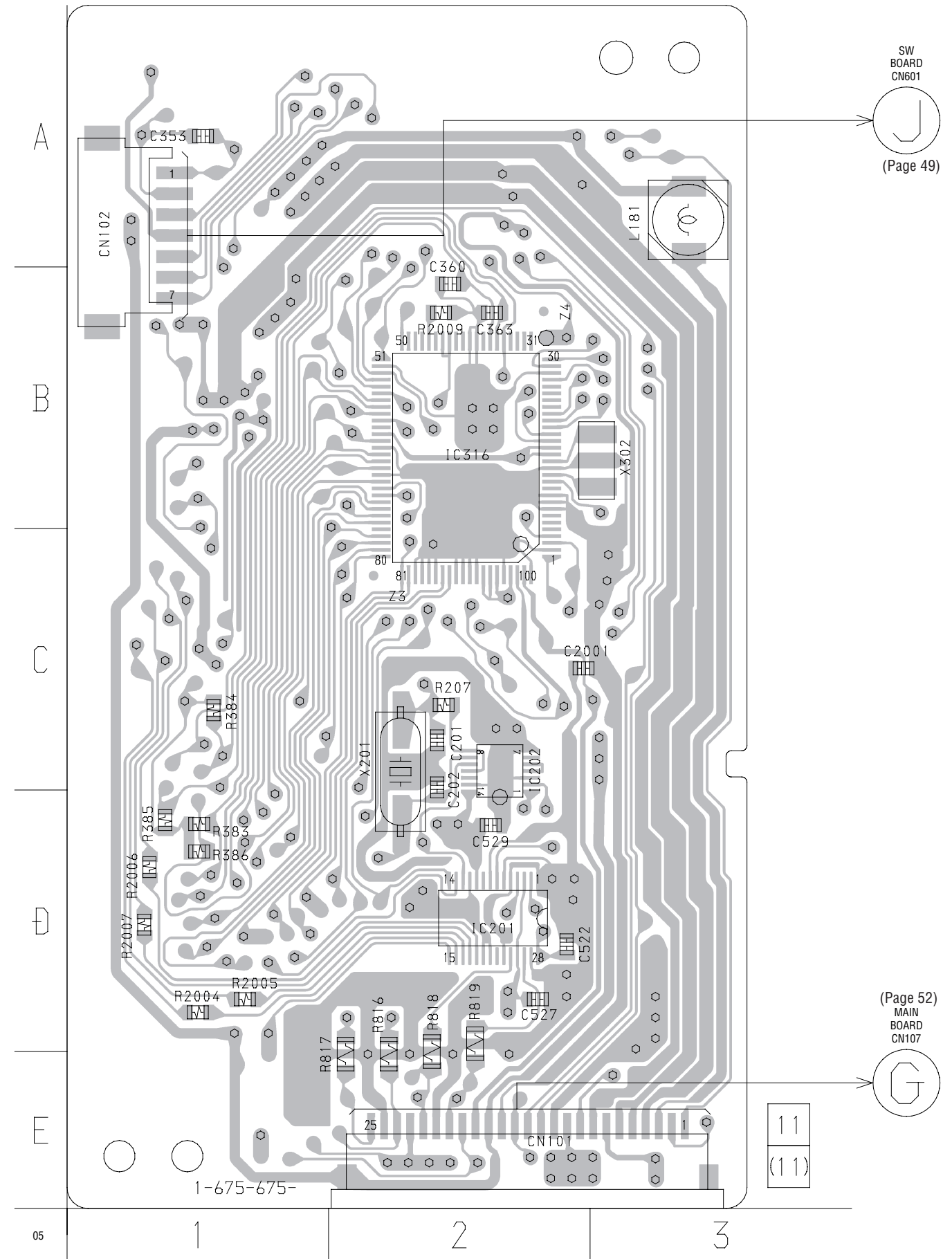

6-16. SCHEMATIC DIAGRAM – MD DIGITAL Board – • See page 62 for waveforms. • See page 63 for IC Block Diagrams.

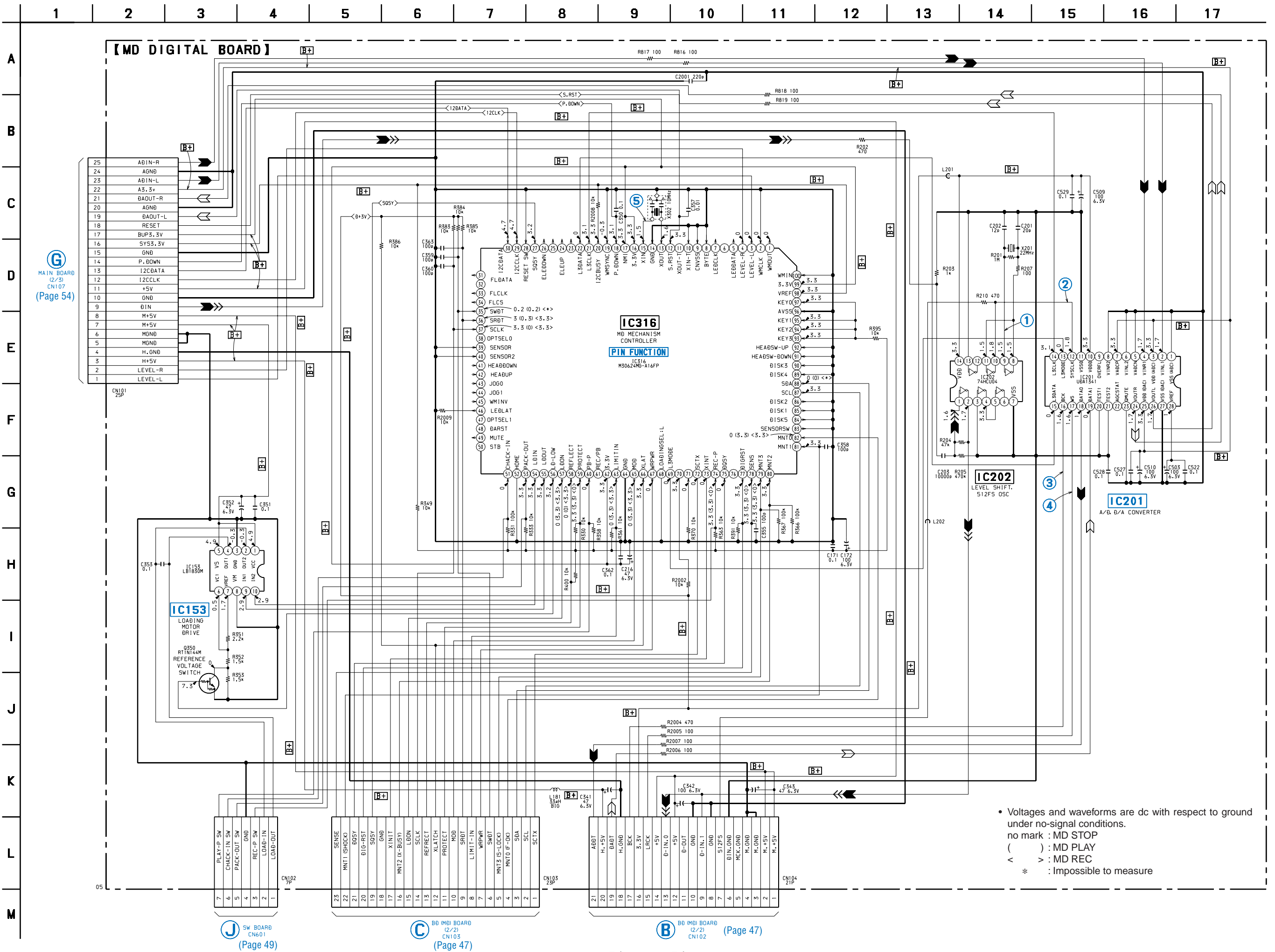

• Voltages and waveforms are dc with respect to ground under no-signal conditions.
 no mark : MD STOP
 () : MD PLAY
 < > : MD REC
 * : Impossible to measure

G MAIN BOARD (2/3) CN107 (Page 54)

J SW BOARD CN601 (Page 49)

C BB (MD) BOARD (2/2) CN105 (Page 47)

B BB (MD) BOARD (2/2) CN102 (Page 47)

6-17. PRINTED WIRING BOARD – MAIN Board – • See page 43 for Circuit Boards Location.

• Semiconductor Location

Ref. No.	Location
D171	E-2
D901	B-7
D911	D-7
D912	D-6
D913	D-6
D914	D-6
D921	E-6
D922	E-5
D923	E-5
D924	E-5
D941	E-7
D942	E-5
D943	E-4
D946	C-4
IC171	E-2
IC301	C-9
IC501	C-3
IC901	B-7
IC902	B-6
IC903	C-7
IC911	C-7
IC912	D-7
IC913	C-6
IC921	E-6
IC931	D-5
IC941	E-4
Q101	B-11
Q102	C-4
Q111	E-11
Q112	E-11
Q151	A-11
Q301	C-10
Q351	D-10
Q501	D-6
Q551	D-5
Q552	D-4
Q911	B-6
Q912	B-6
Q921	E-5
Q931	D-4
Q941	E-4

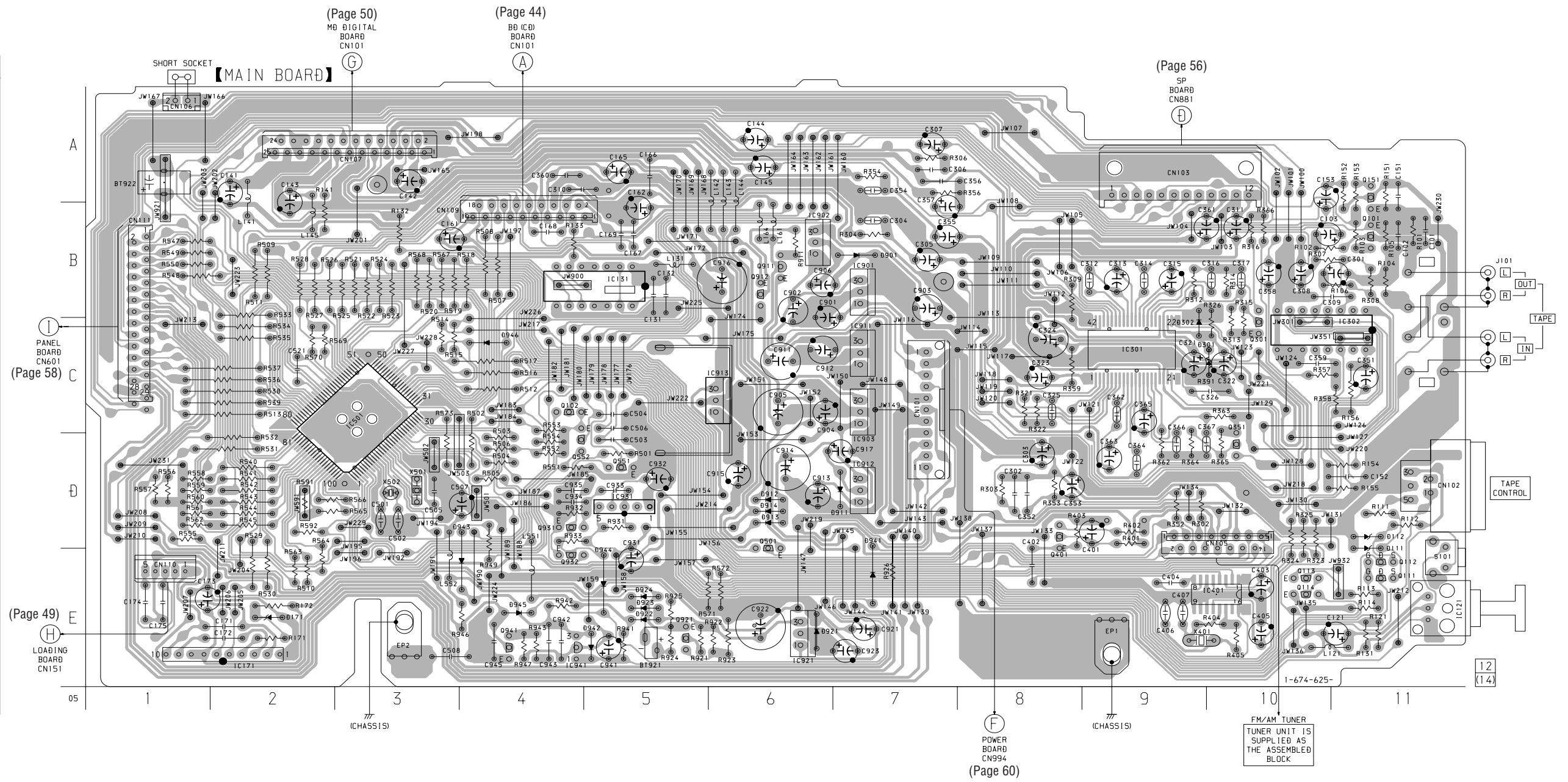

There are a few cases that the part isn't mounted in model is printed on diagrams.

6-18. SCHEMATIC DIAGRAM – MAIN Board (1/3) – • See page 63 for IC Block Diagrams.

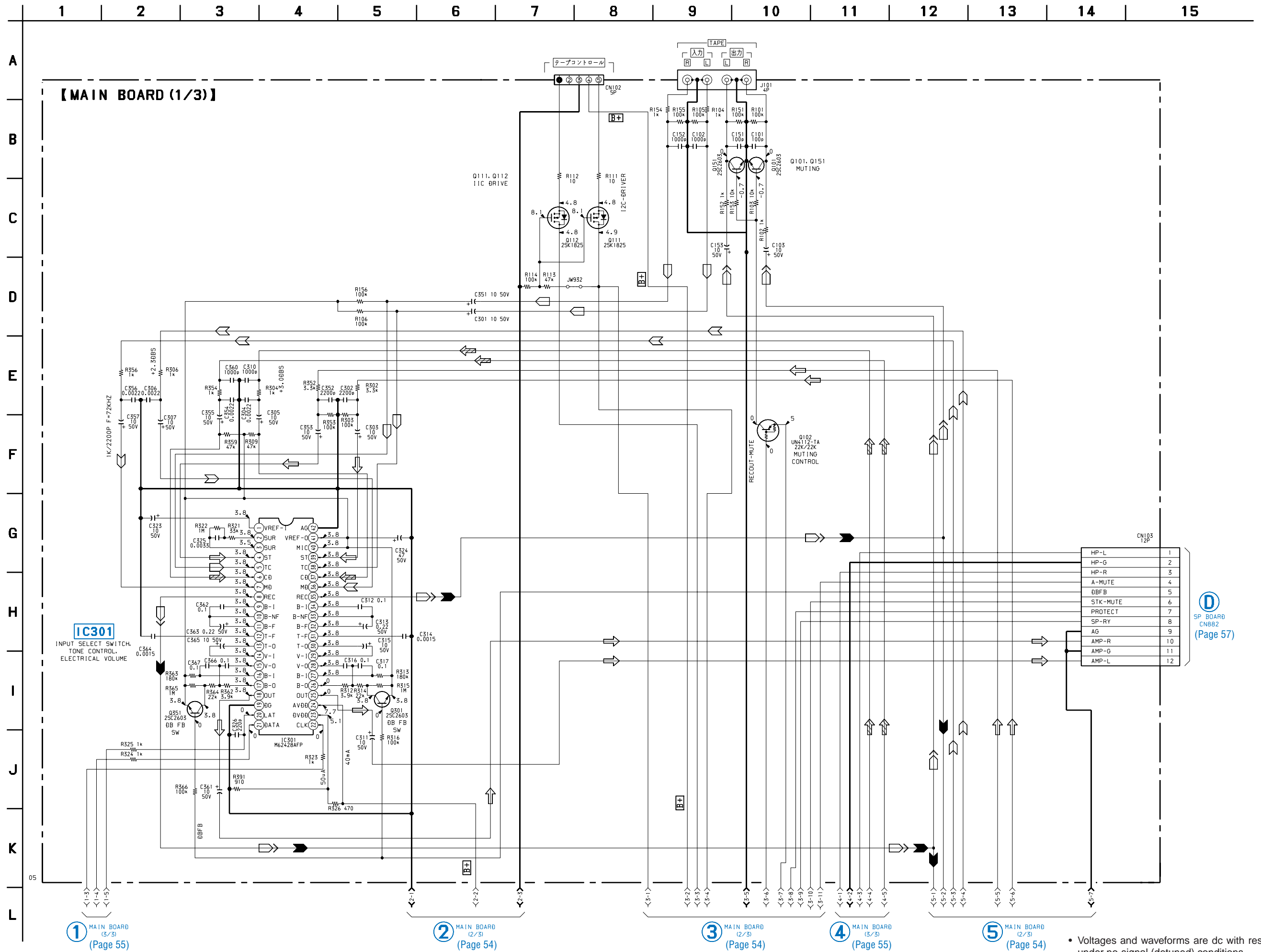

• Voltages and waveforms are dc with respect to ground under no-signal (detuned) conditions.
no mark : TUNER

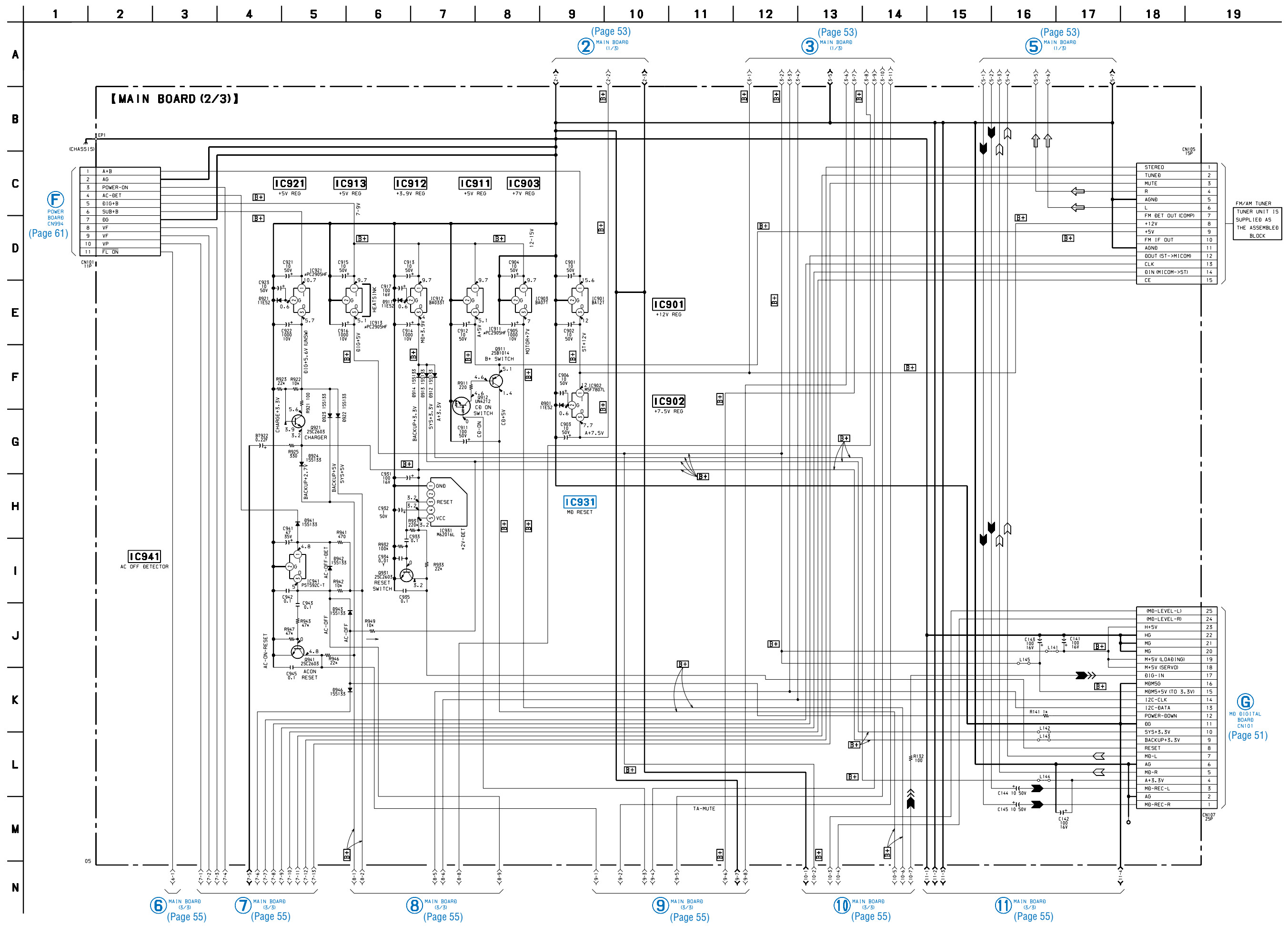

• Voltages and waveforms are dc with respect to ground under no-signal (detuned) conditions.
 no mark : TUNER

6-20. SCHEMATIC DIAGRAM – MAIN Board (3/3) – • See page 62 for Waveforms. • See page 63 for IC Block Diagrams.

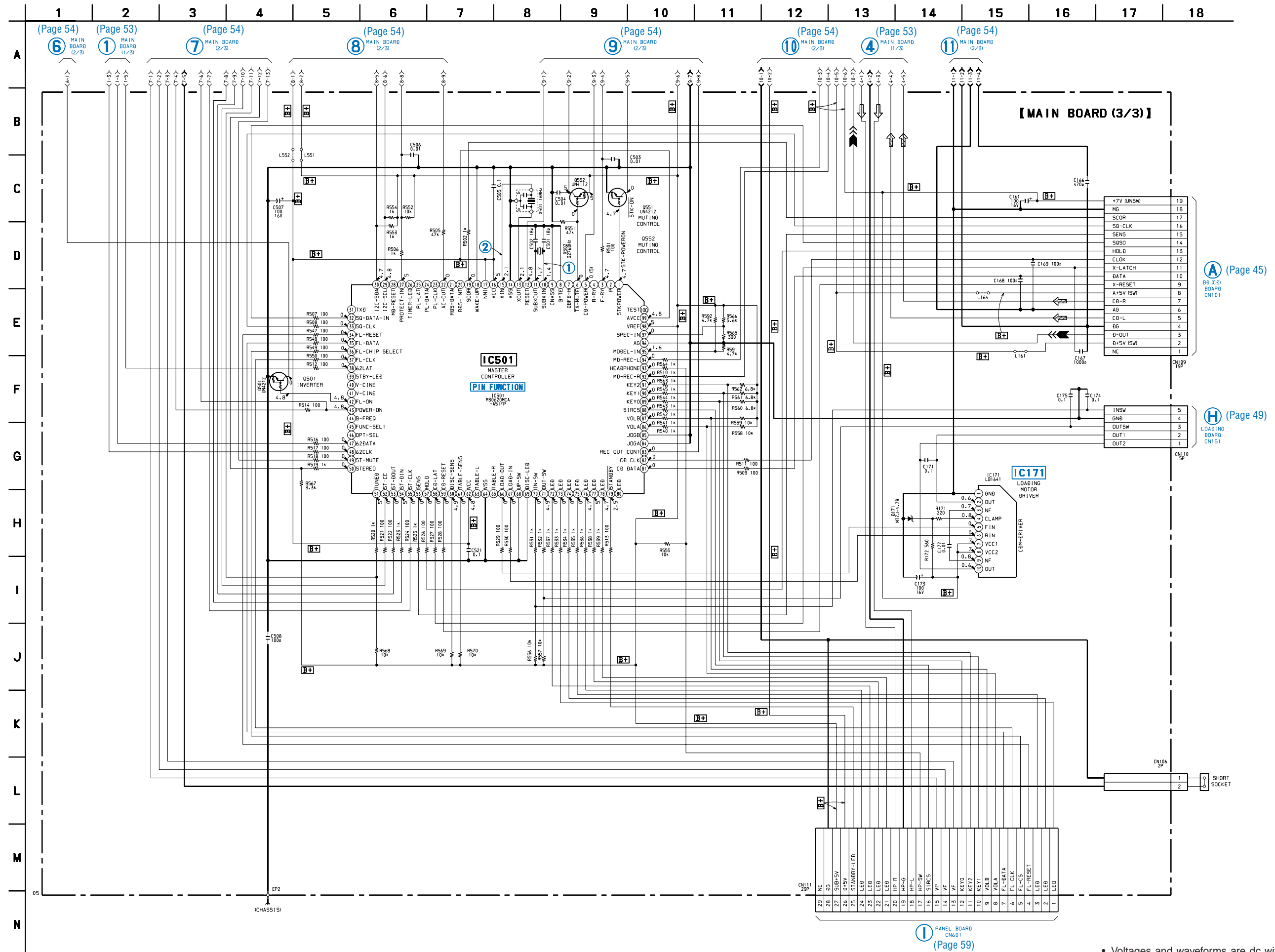

• Voltages and waveforms are dc with respect to ground under no-signal (detuned) conditions.
 no mark : TUNER
 () : CD

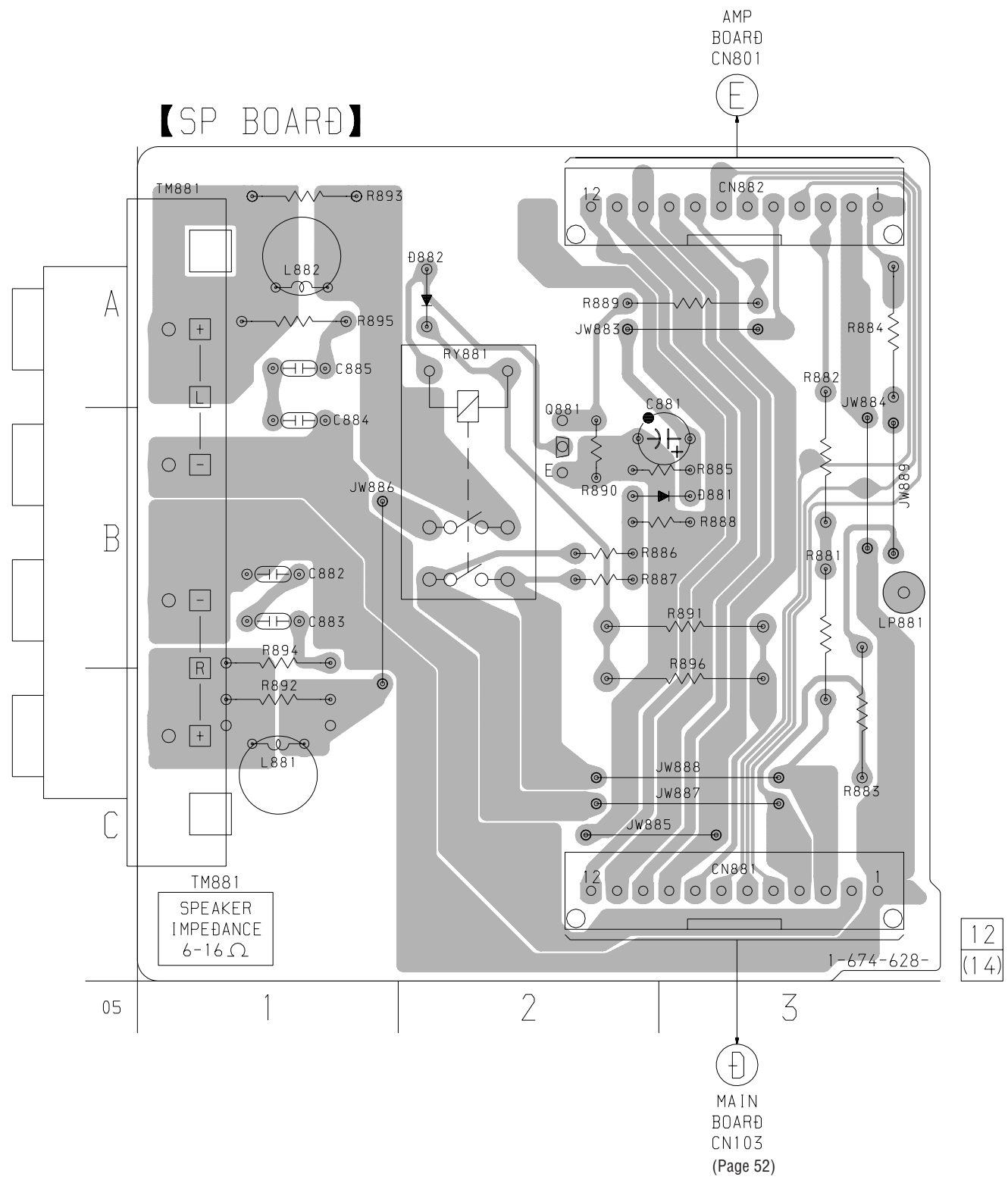
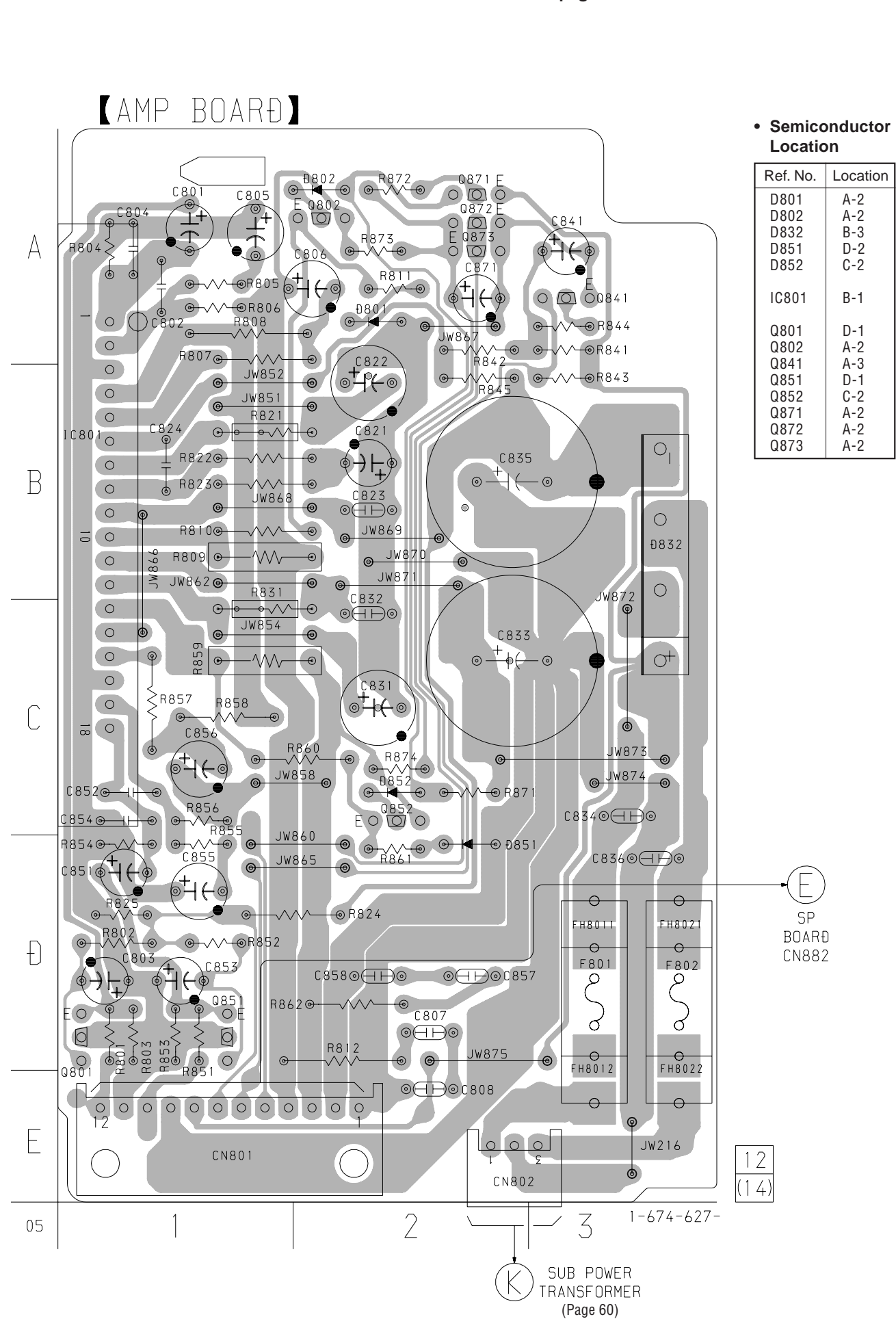

There are a few cases that the part isn't mounted in model is printed on diagrams.

6-22. SCHEMATIC DIAGRAM – AMP/SP Boards –

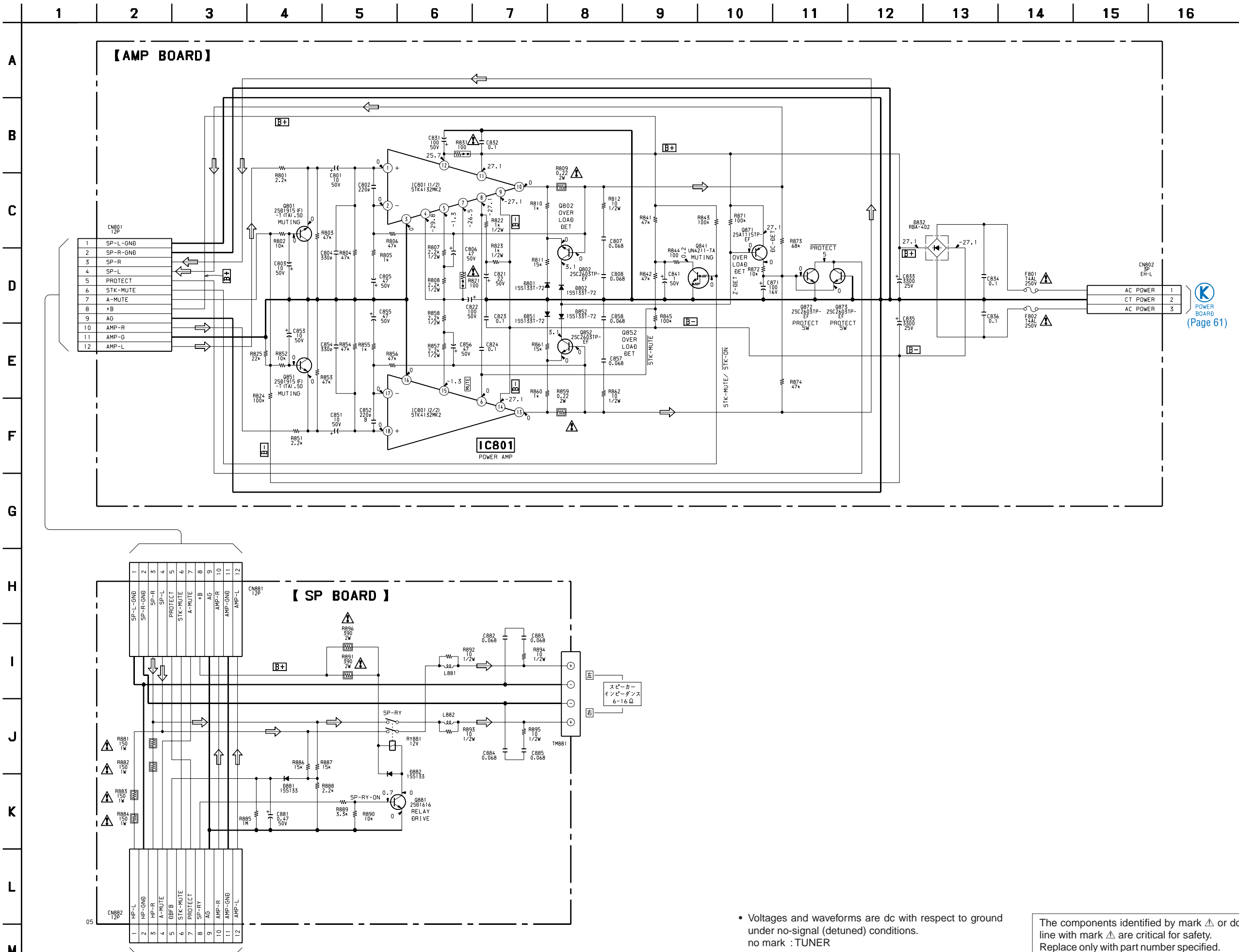

K
POWER BOARD
(Page 61)

• Voltages and waveforms are dc with respect to ground under no-signal (detuned) conditions.
no mark : TUNER

The components identified by mark Δ or dotted line with mark Δ are critical for safety.
Replace only with part number specified.

6-23. PRINTED WIRING BOARD – PANEL Board – • See page 43 for Circuit Boards Location.

[PANEL BOARD]

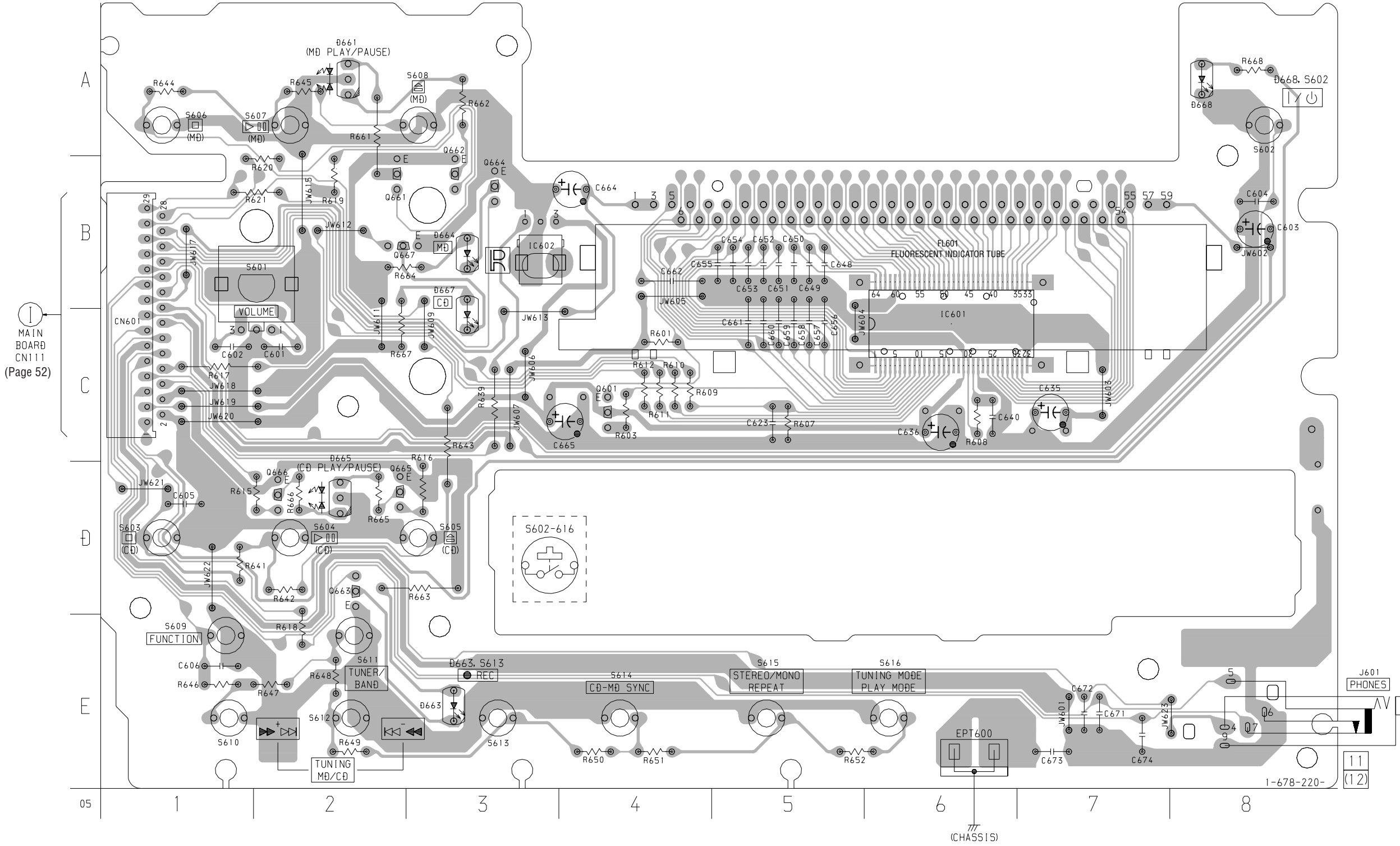

• Semiconductor Location

Ref. No.	Location
D661	A-2
D663	E-3
D664	B-3
D665	D-2
D667	C-3
D668	A-8
IC601	C-6
IC602	B-3
Q601	C-4
Q661	B-2
Q662	B-3
Q663	D-2
Q664	B-3
Q665	D-2
Q666	D-2
Q667	B-2

6-24. SCHEMATIC DIAGRAM – PANEL Board – • See page 62 for Waveform. • See page 63 for IC Block Diagram.

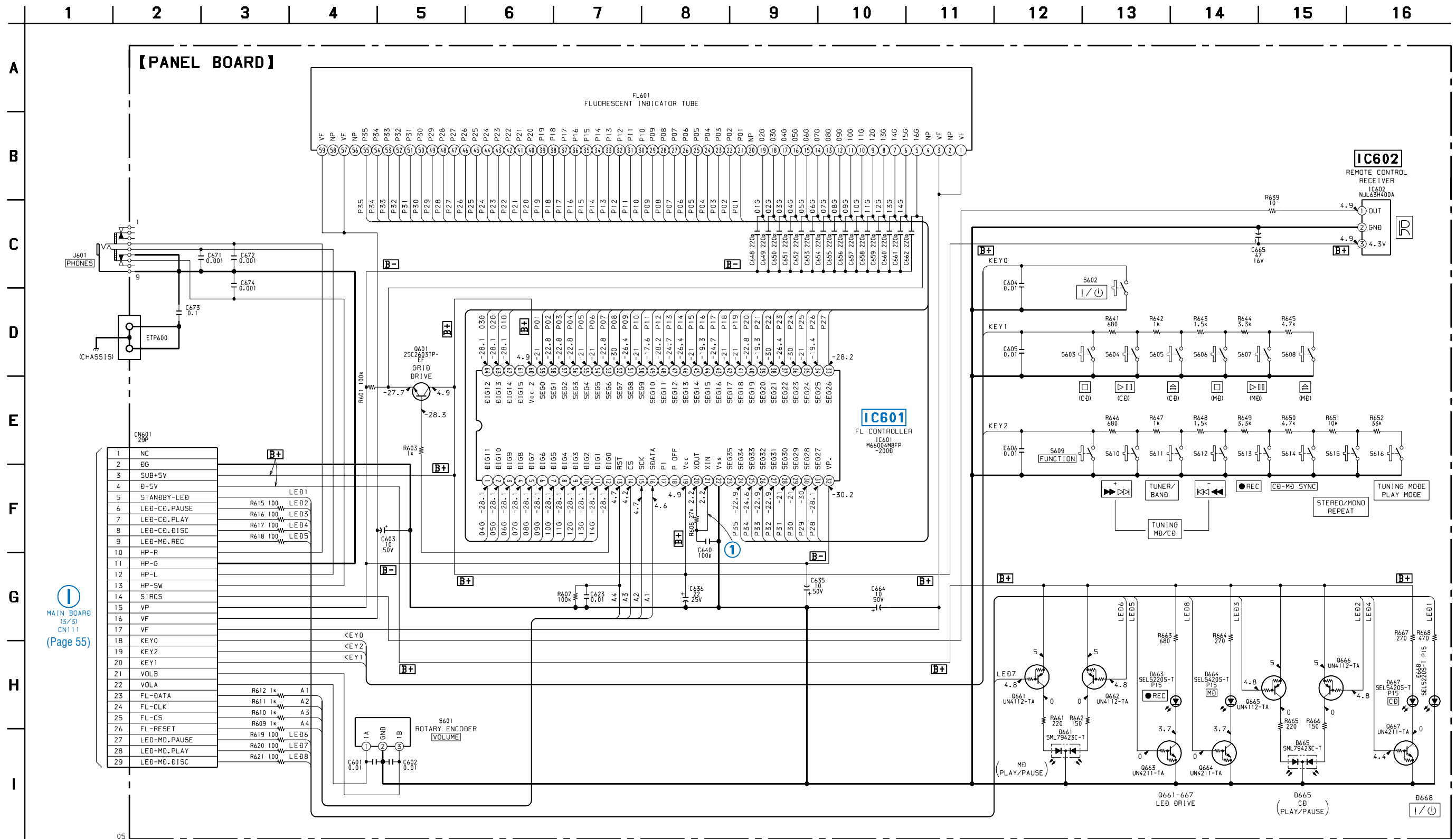

• Voltages and waveforms are dc with respect to ground under no-signal (detuned) conditions.
no mark : TUNER

6-25. PRINTED WIRING BOARD – POWER Board – • See page 43 for Circuit Boards Location.

• Semiconductor Location

Ref. No.	Location
D971	B-3
D972	B-2
D973	B-3
D974	B-2
D975	A-3
D976	A-3
D977	A-3
D978	A-3
D979	A-2
D980	A-3
D981	B-1
D982	A-1
D983	A-1
D984	A-1
D985	A-1
D986	A-5
D987	A-5
D991	A-4
D992	C-2
D993	C-2
Q971	B-2
Q972	A-5
Q973	A-5
Q974	A-4
Q975	B-3
Q991	B-3

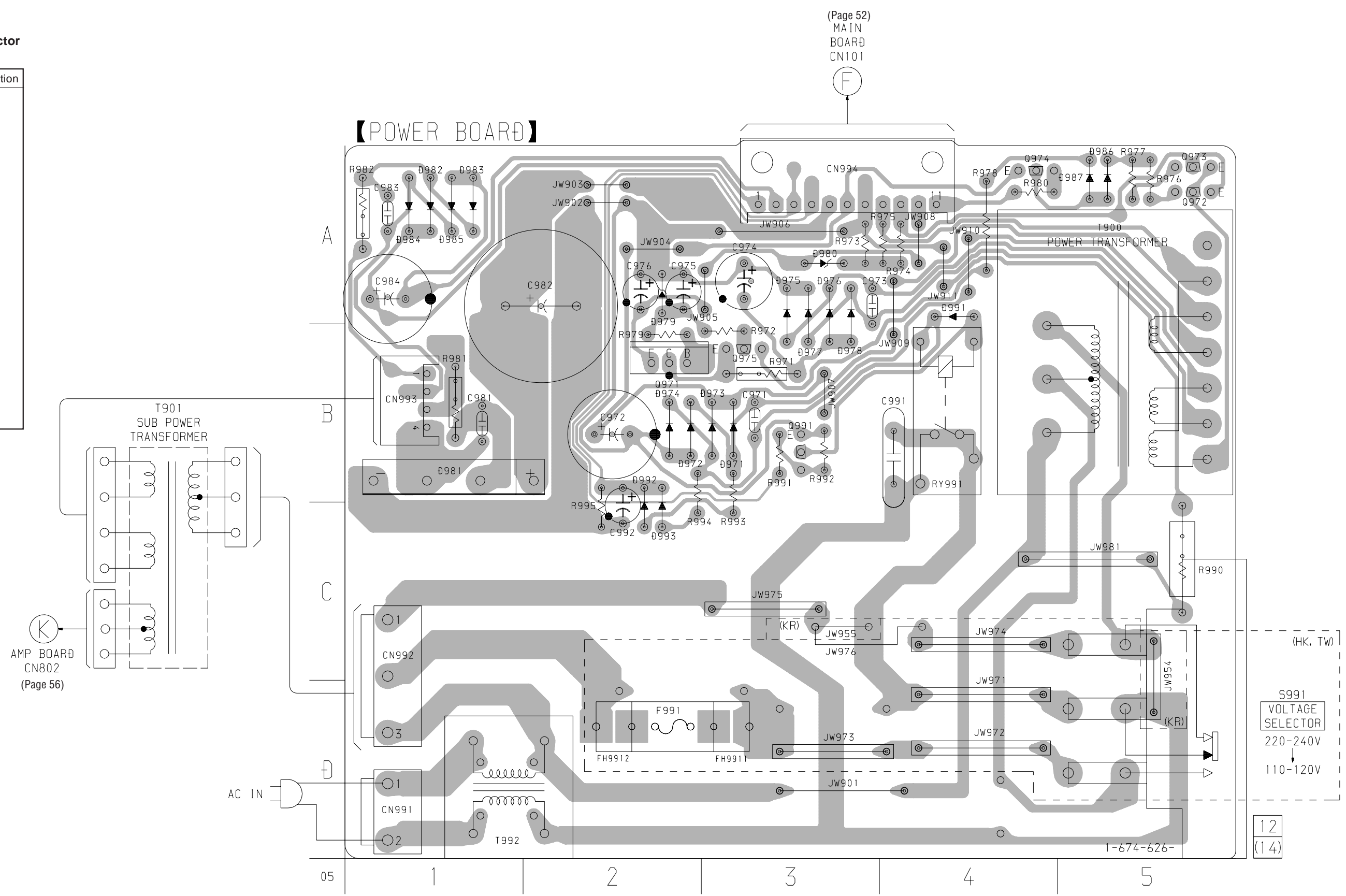

There are a few cases that the part isn't mounted in model is printed on diagrams.

6-26. SCHEMATIC DIAGRAM – POWER Board –

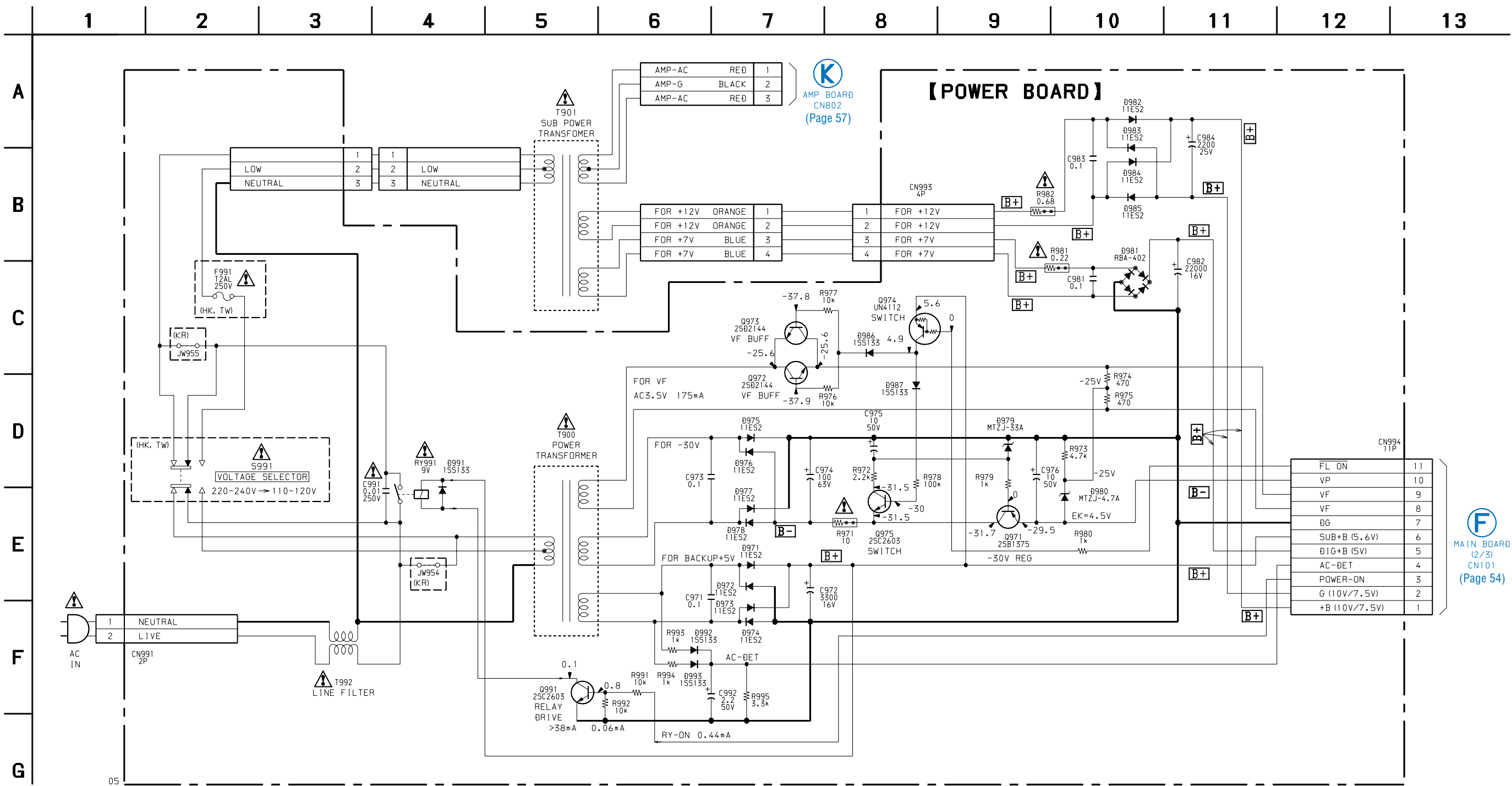

• Voltages and waveforms are dc with respect to ground under no-signal (detuned) conditions.
no mark : TUNER

The components identified by mark Δ or dotted line with mark Δ are critical for safety.
Replace only with part number specified.

• Waveforms

– BD (CD) Board –

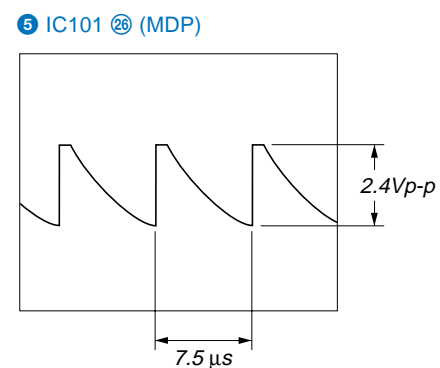
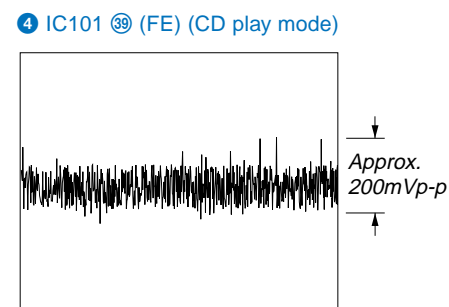
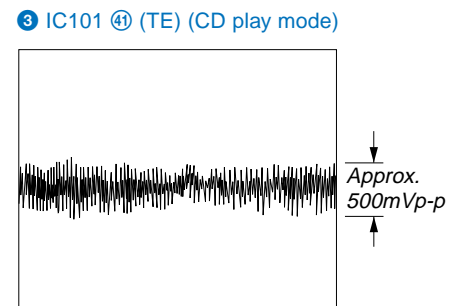
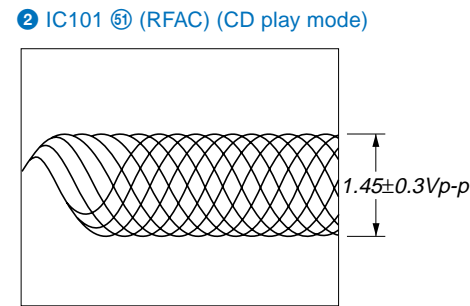
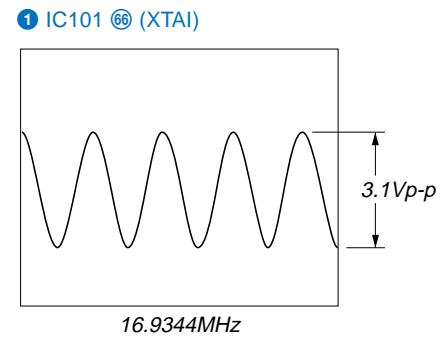

– BD (MD) Board –

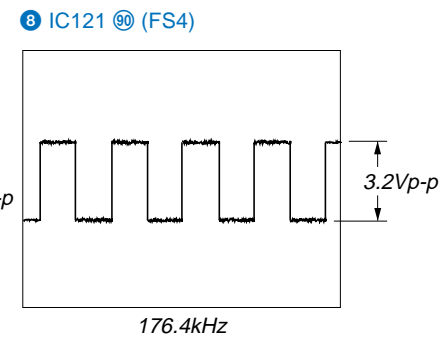
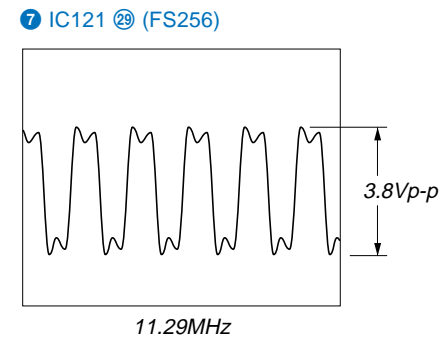
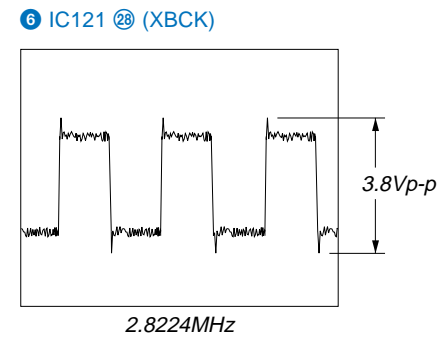
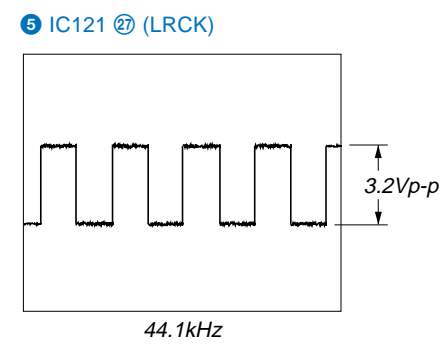
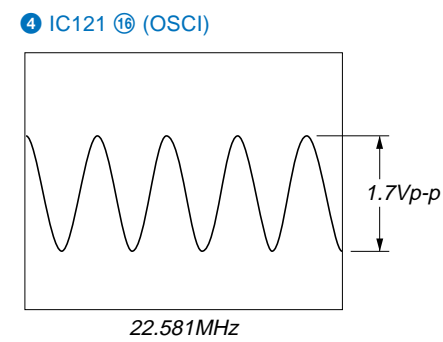
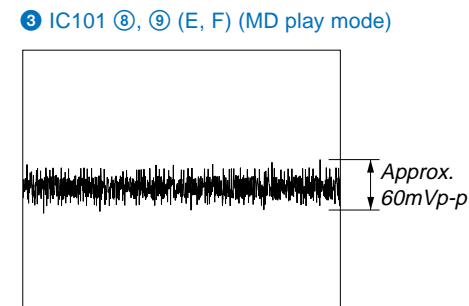
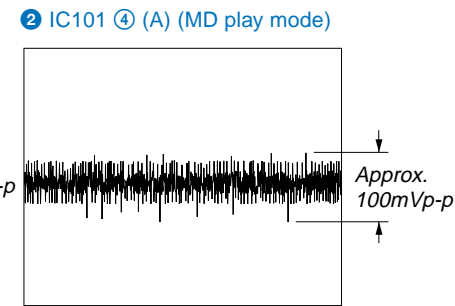
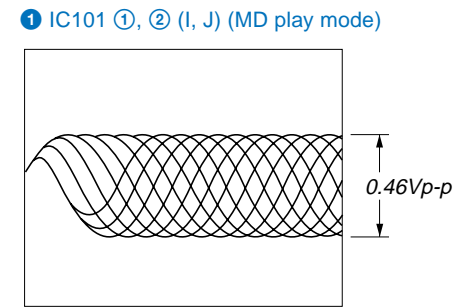

– MD DIGITAL Board –

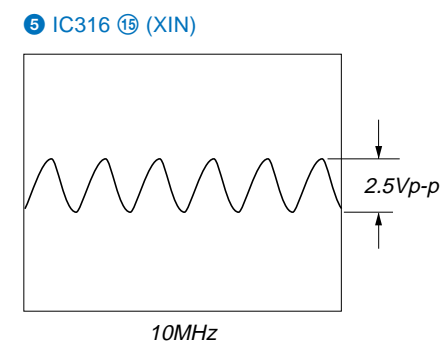
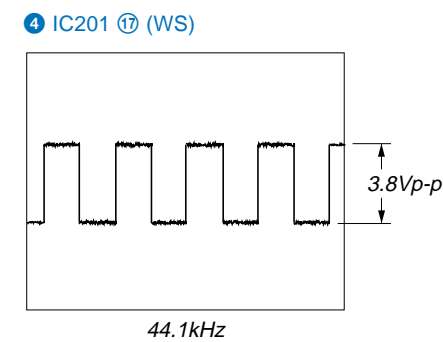
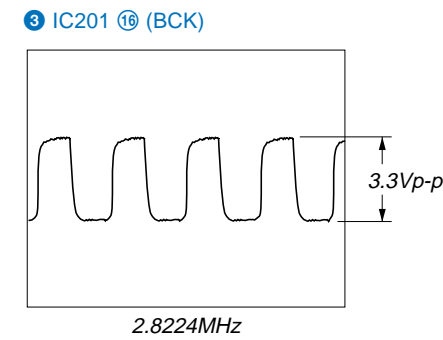
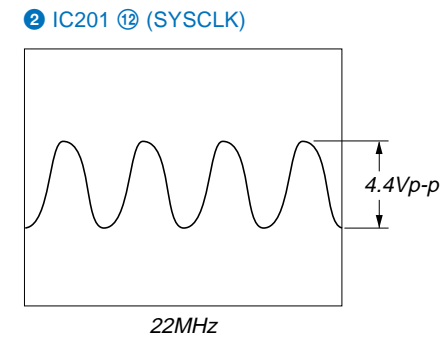
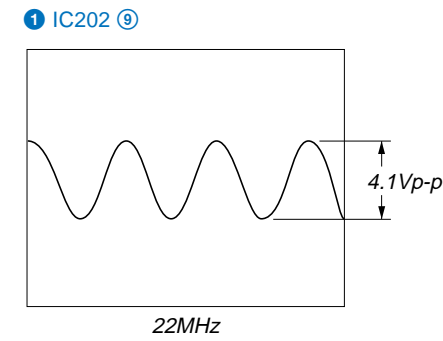

– MAIN Board –

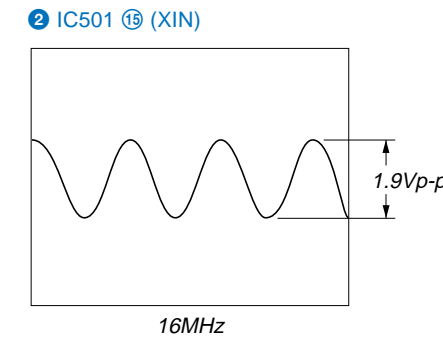
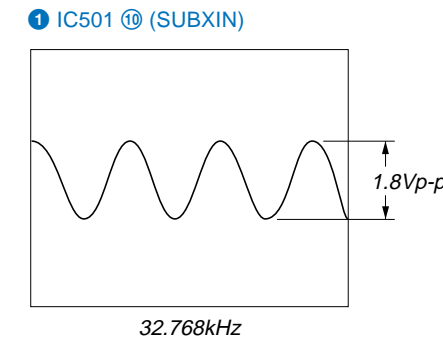

– PANEL Board –

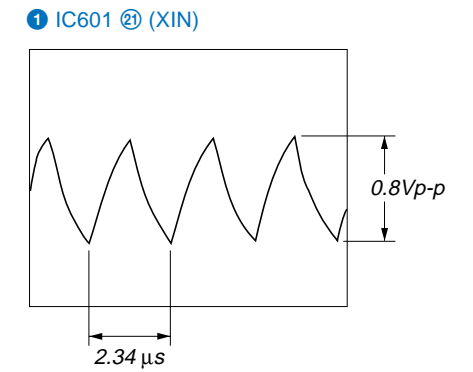

• IC Block Diagrams
– BD (CD) Board –

IC101 CXD2587Q

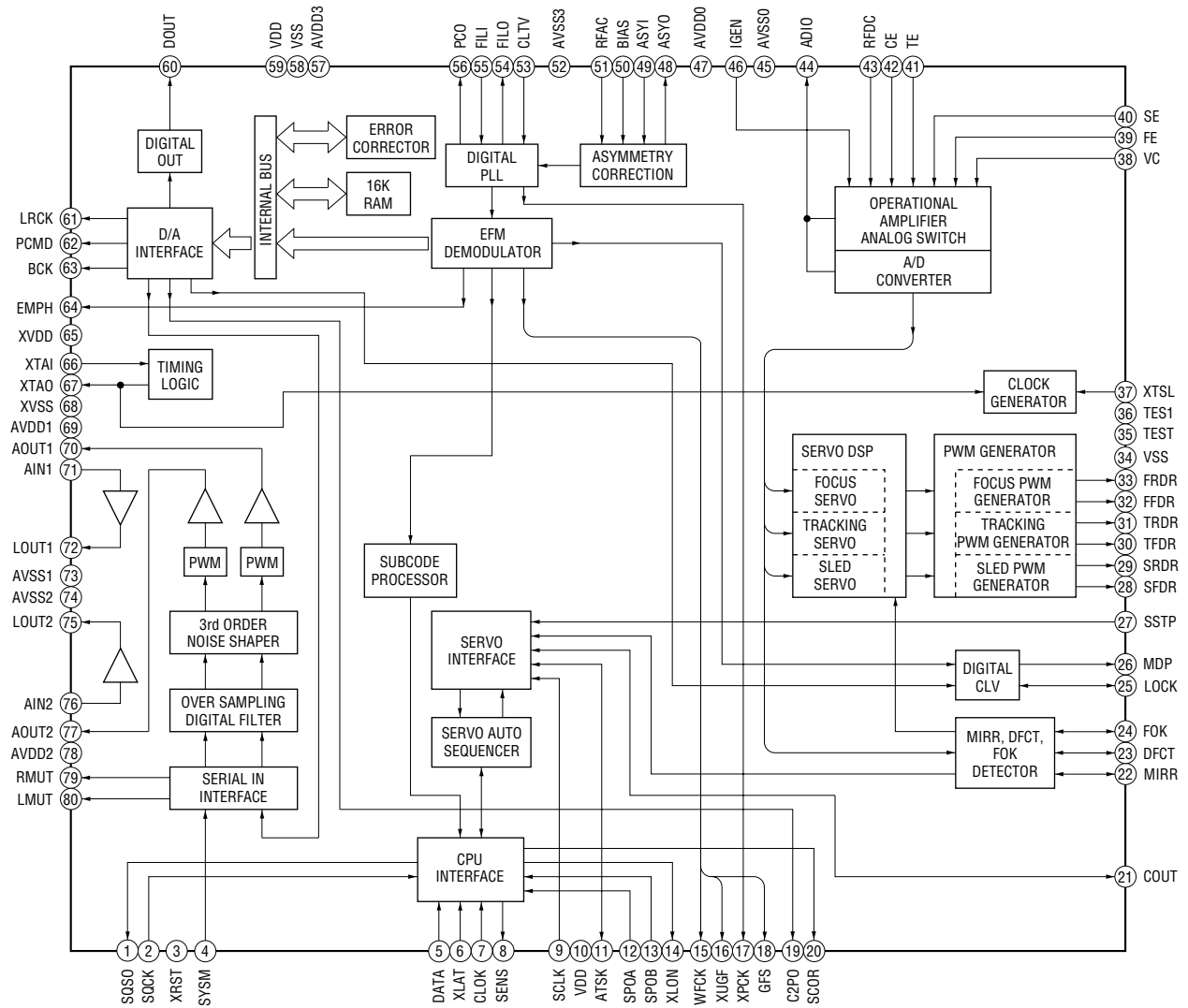

IC102 BA5974FP-E2

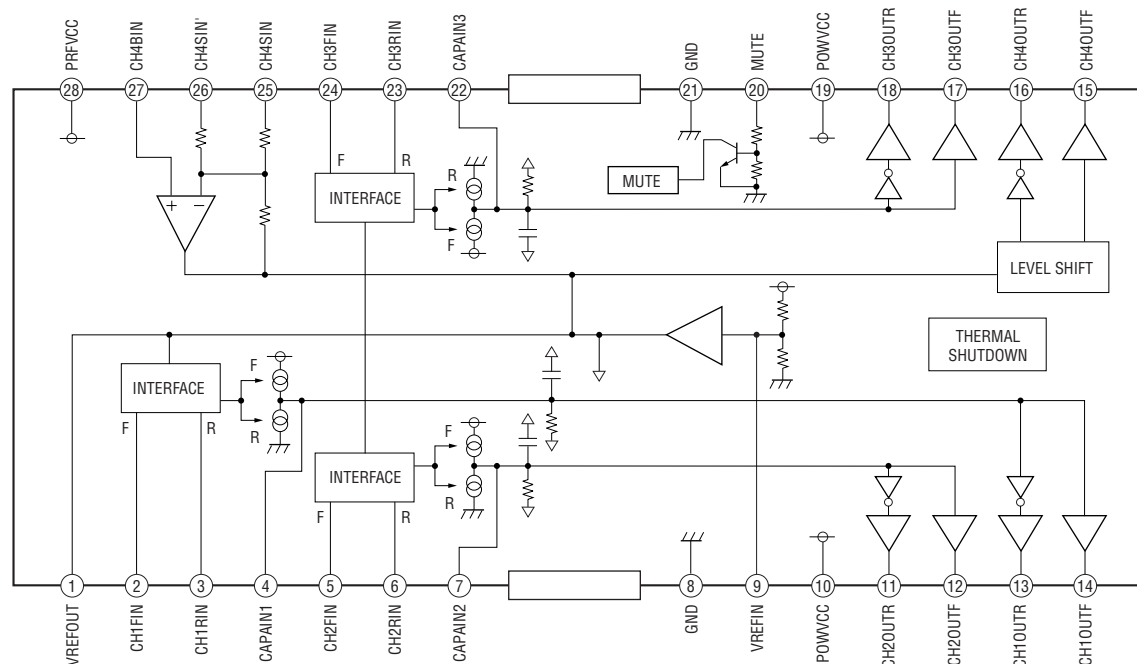

IC103 CXA2568M-T6

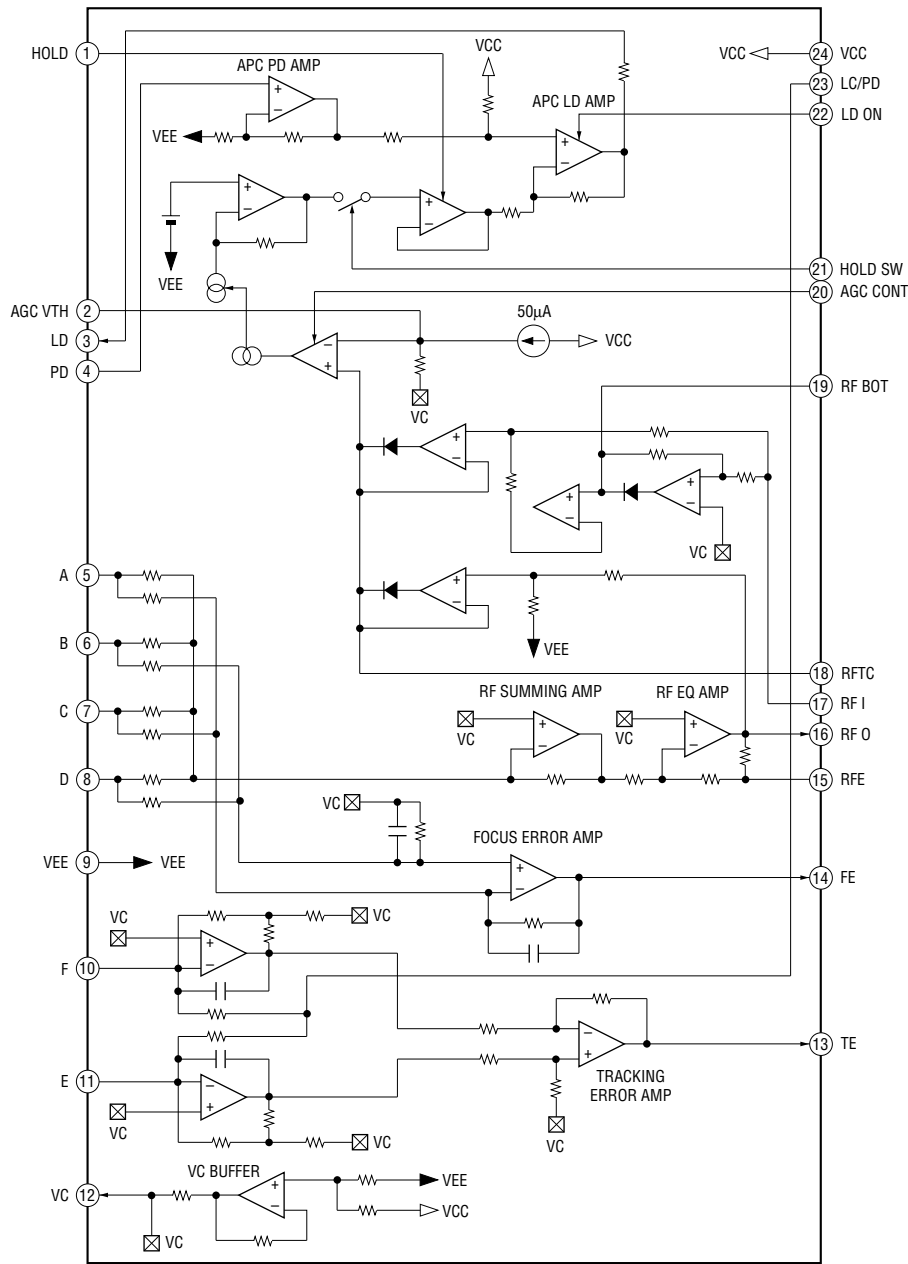

- BD (MD) Board -

IC101 CXA2523AR

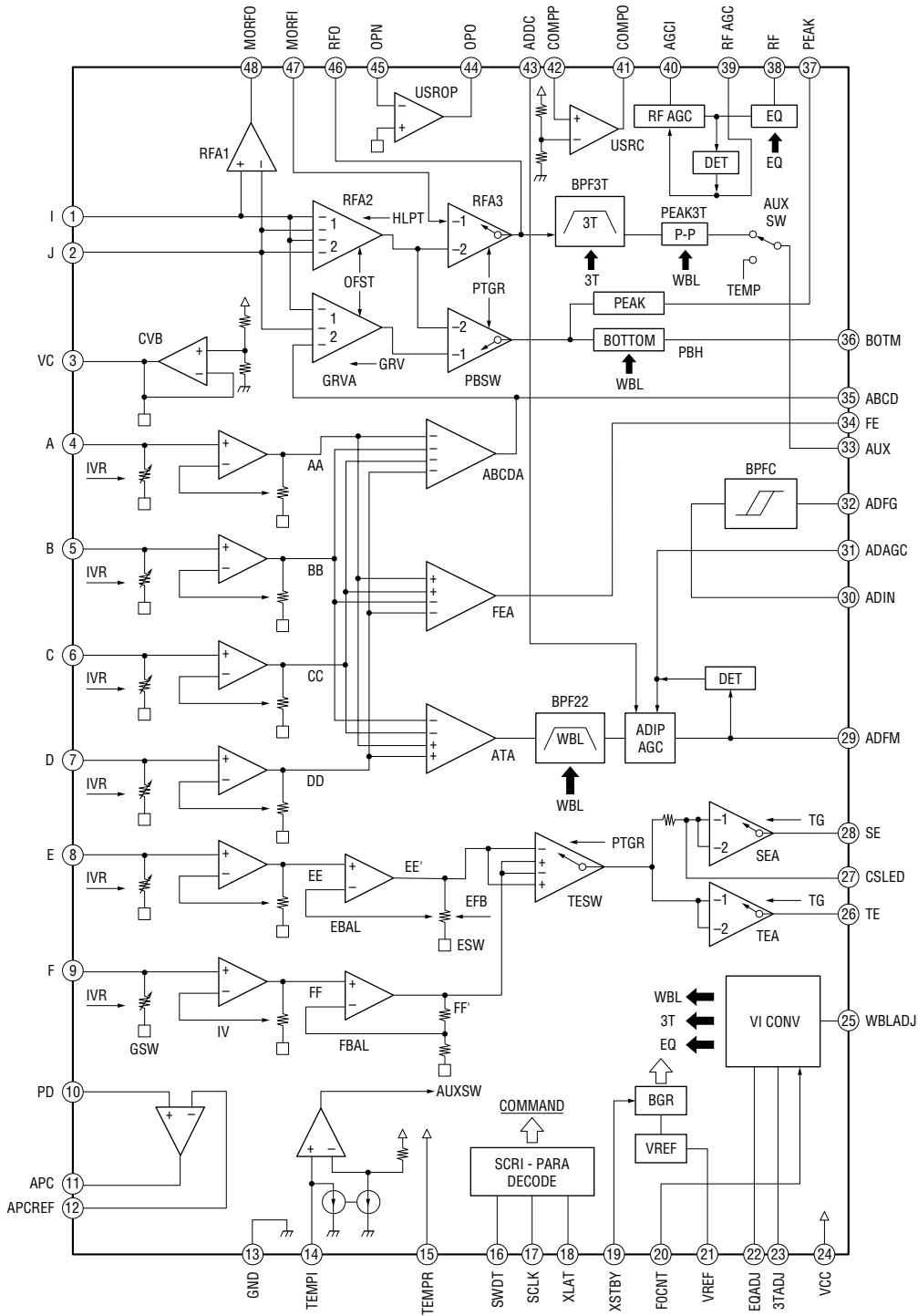

IC121 CXD2654R

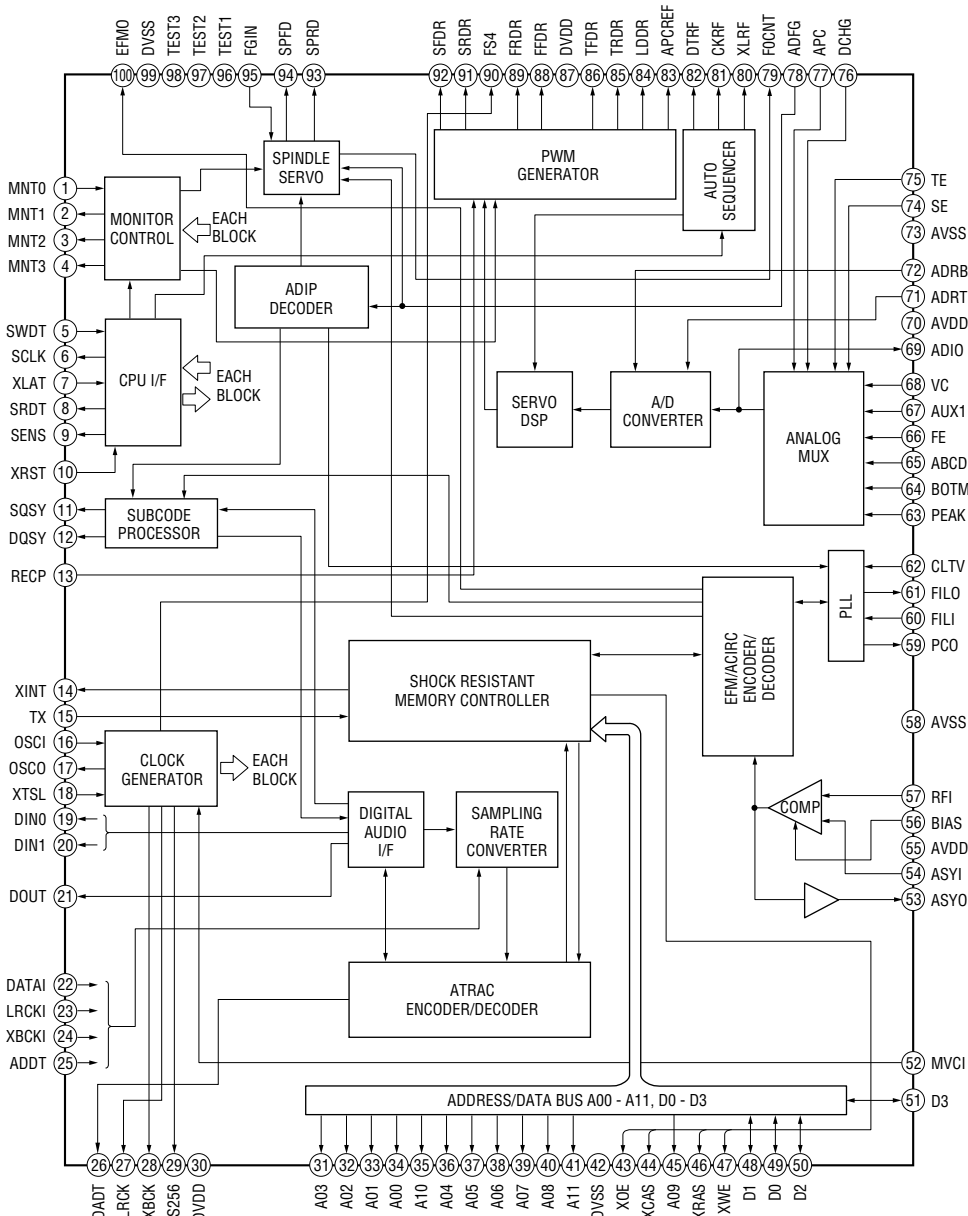

IC152 BH6511FS

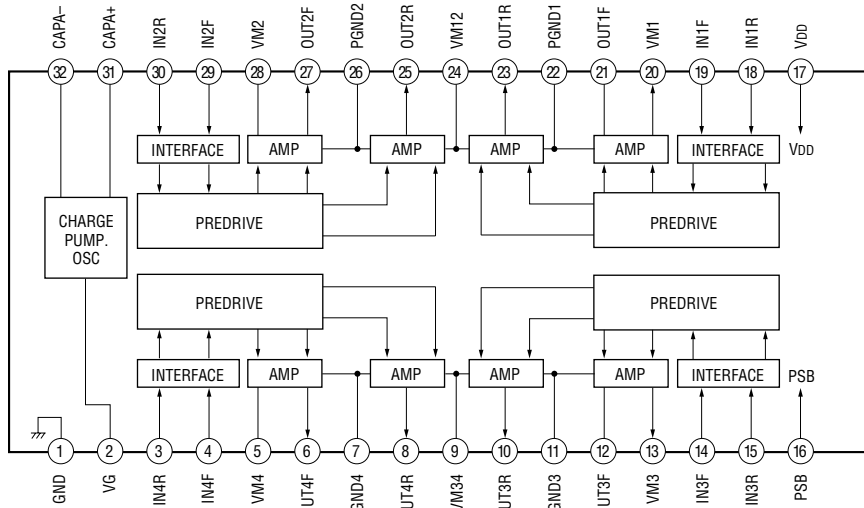

– MD DIGITAL Board –

IC153 LB1830M-S-TE-L

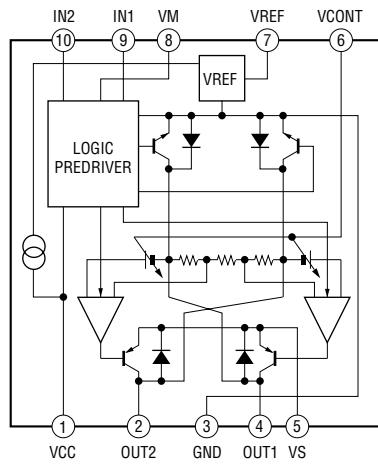

IC201 UDA1341TS

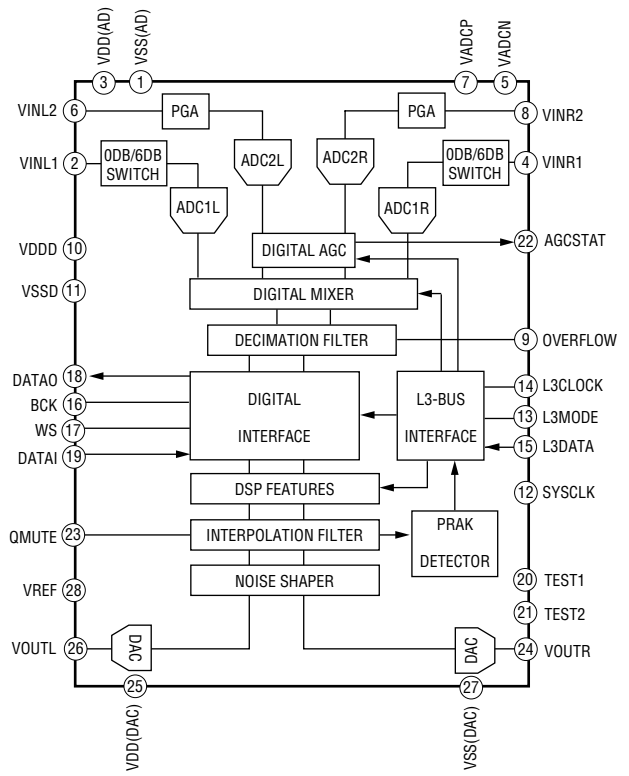

– MAIN Board –

IC301 M62428AFP600C

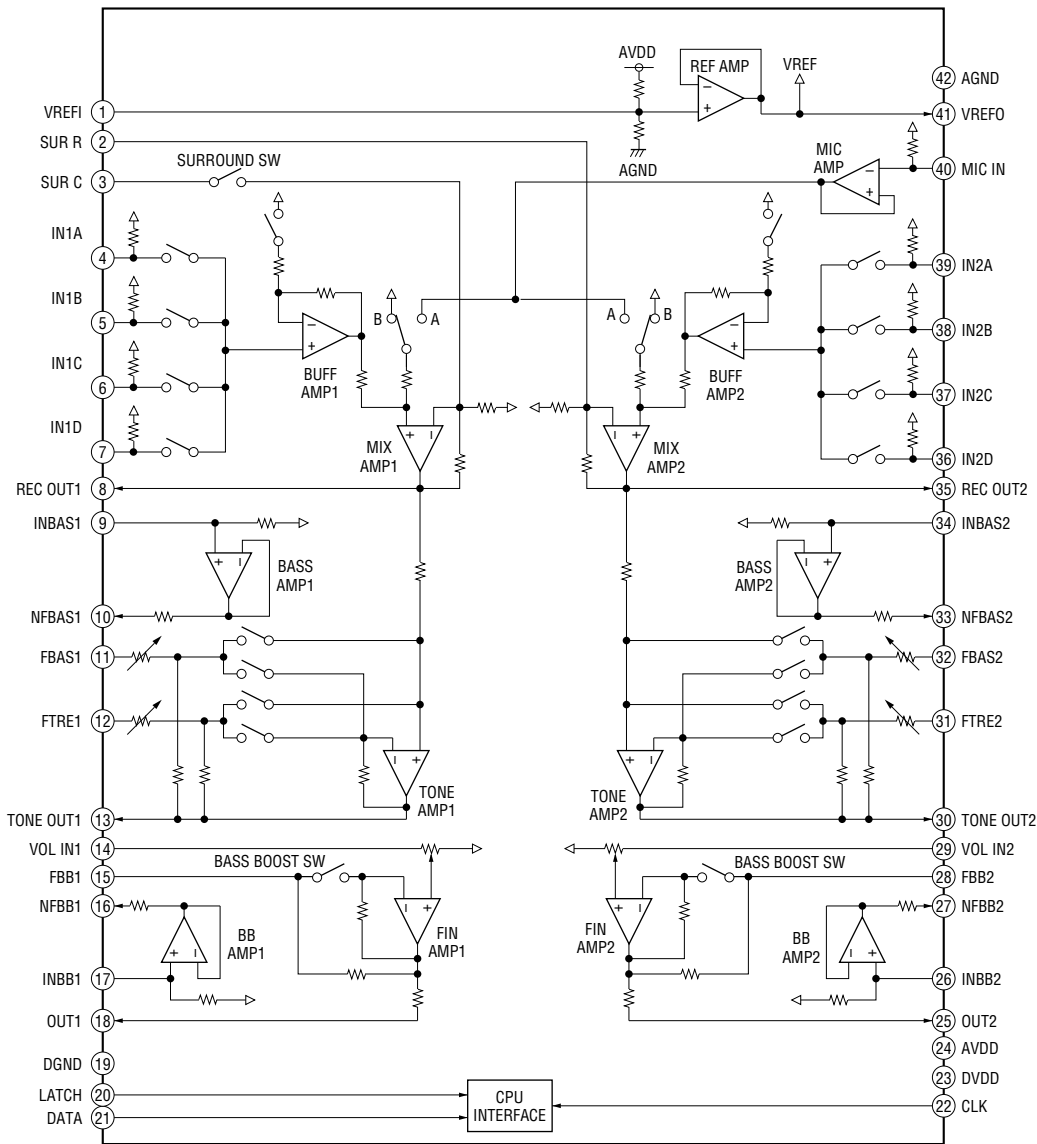

IC171 LB1641

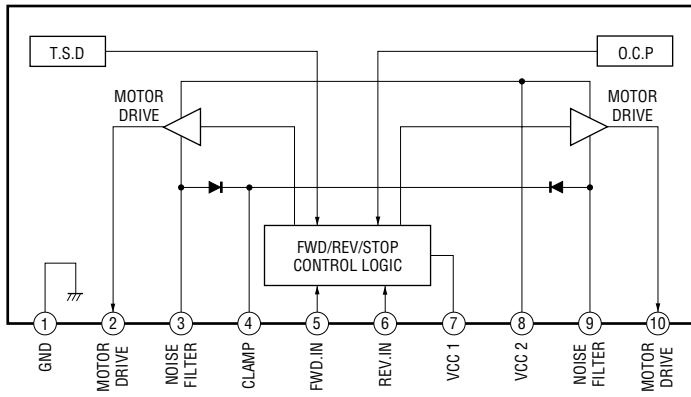

IC931 M62016L

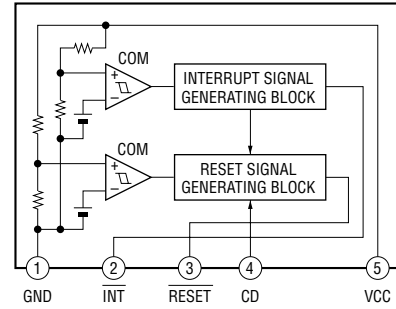

- PANEL Board -

IC601 M66004M8FP

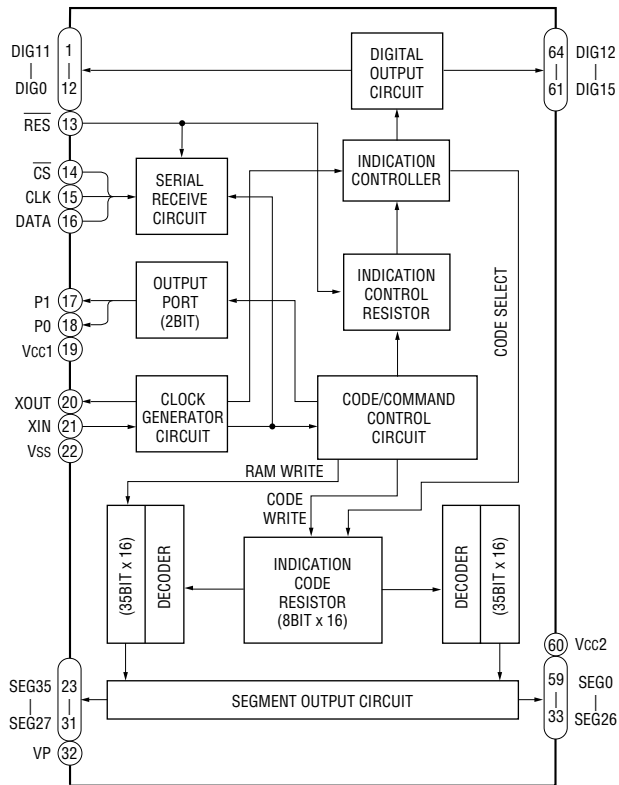

6-27. IC PIN FUNCTION DESCRIPTION

• BD (MD) BOARD IC101 CXA2523AR (RF AMP, FOCUS/TRACKING ERROR AMP)

Pin No.	Pin Name	I/O	Description
1	I	I	I-V converted RF signal I input from the optical pick-up block detector
2	J	I	I-V converted RF signal J input from the optical pick-up block detector
3	VC	O	Middle point voltage (+1.65V) generation output terminal
4 to 9	A to F	I	Signal input from the optical pick-up detector
10	PD	I	Light amount monitor input from the optical pick-up block laser diode
11	APC	O	Laser amplifier output terminal to the automatic power control circuit
12	APCREF	I	Reference voltage input for setting laser power from the CXD2654R (IC121)
13	GND	—	Ground terminal
14	TEMPI	I	Connected to the temperature sensor
15	TEMPR	O	Output terminal for a temperature sensor reference voltage
16	SWDT	I	Writing serial data input from the CXD2654R (IC121)
17	SCLK	I	Serial data transfer clock signal input from the CXD2654R (IC121)
18	XLAT	I	Serial data latch pulse signal input from the CXD2654R (IC121)
19	XSTBY	I	Standby signal input terminal “L”: standby (fixed at “H” in this set)
20	F0CNT	I	Center frequency control voltage input terminal of internal circuit (BPF22, BPF3T, EQ) input from the CXD2654R (IC121)
21	VREF	O	Reference voltage output terminal Not used (open)
22	EQADJ	I	Center frequency setting terminal for the internal circuit (EQ)
23	3TADJ	I	Center frequency setting terminal for the internal circuit (BPF3T)
24	VCC	—	Power supply terminal (+3.3V)
25	WBLADJ	I	Center frequency setting terminal for the internal circuit (BPF22)
26	TE	O	Tracking error signal output to the CXD2654R (IC121)
27	CSLED	I	Connected to the external capacitor for low-pass filter of the sled error signal
28	SE	O	Sled error signal output to the CXD2654R (IC121)
29	ADFM	O	FM signal output of the ADIP
30	ADIN	I	Receives a ADIP FM signal in AC coupling
31	ADAGC	I	Connected to the external capacitor for ADIP AGC
32	ADFG	O	ADIP duplex signal (22.05 kHz ± 1 kHz) output to the CXD2654R (IC121)
33	AUX	O	Auxiliary signal (I ₃ signal/temperature signal) output to the CXD2654R (IC121)
34	FE	O	Focus error signal output to the CXD2654R (IC121)
35	ABCD	O	Light amount signal (ABCD) output to the CXD2654R (IC121)
36	BOTM	O	Light amount signal (RF/ABCD) bottom hold output to the CXD2654R (IC121)
37	PEAK	O	Light amount signal (RF/ABCD) peak hold output to the CXD2654R (IC121)
38	RF	O	Playback EFM RF signal output to the CXD2654R (IC121)
39	RFAGC	I	Connected to the external capacitor for RF auto gain control circuit
40	AGCI	I	Receives a RF signal in AC coupling
41	COMPO	O	User comparator output terminal Not used (open)
42	COMPP	I	User comparator input terminal Not used (fixed at “L”)
43	ADDC	I	Connected to the external capacitor for cutting the low band of the ADIP amplifier
44	OPO	O	User operational amplifier output terminal Not used (open)
45	OPN	I	User operational amplifier inversion input terminal Not used (fixed at “L”)
46	RFO	O	RF signal output terminal
47	MORFI	I	Receives a MO RF signal in AC coupling
48	MORFO	O	MO RF signal output terminal

• **BD (MD) BOARD IC121 CXD2654R**
(DIGITAL SIGNAL PROCESSOR, DIGITAL SERVO PROCESSOR, EFM/ACIRC ENCODER/DECODER, SHOCK PROOF MEMORY CONTROLLER, ATRAC ENCODER/DECODER)

Pin No.	Pin Name	I/O	Description
1	MNT0 (FOK)	O	Focus OK signal output to the MD mechanism controller (IC316) “H” is output when focus is on (“L”: NG)
2	MNT1 (SHOCK)	O	Track jump detection signal output to the MD mechanism controller (IC316)
3	MNT2 (XBUSY)	O	Busy monitor signal output to the MD mechanism controller (IC316)
4	MNT3 (SLOCK)	O	Spindle servo lock status monitor signal output to the MD mechanism controller (IC316)
5	SWDT	I	Writing serial data signal input from the MD mechanism controller (IC316)
6	SCLK	I (S)	Serial data transfer clock signal input from the MD mechanism controller (IC316)
7	XLAT	I (S)	Serial data latch pulse signal input from the MD mechanism controller (IC316)
8	SRDT	O (3)	Reading serial data signal output to the MD mechanism controller (IC316)
9	SENS	O (3)	Internal status (SENSE) output to the MD mechanism controller (IC316)
10	XRST	I (S)	Reset signal input from the MD mechanism controller (IC316) “L”: reset
11	SQSY	O	Subcode Q sync (SCOR) output to the MD mechanism controller (IC316) “L” is output every 13.3 msec Almost all, “H” is output
12	DQSY	O	Digital In U-bit CD format subcode Q sync (SCOR) output to the MD mechanism controller (IC316) “L” is output every 13.3 msec Almost all, “H” is output
13	RECP	I	Laser power selection signal input from the MD mechanism controller (IC316) “L”: playback mode, “H”: recording mode
14	XINT	O	Interrupt status output to the MD mechanism controller (IC316)
15	TX	O	Recording data output enable signal input from the MD mechanism controller (IC316) Writing data transmission timing input (Also serves as the magnetic head on/off output)
16	OSCI	I	System clock signal (512Fs=90.3168 MHz) input terminal
17	OSCO	O	System clock signal (512Fs=90.3168 MHz) output terminal Not used (open)
18	XTSL	I	Input terminal for the system clock frequency setting “L”: 45.1584 MHz, “H”: 22.5792 MHz (fixed at “H” in this set)
19	DIN0	I	Digital audio signal input terminal when recording mode Not used
20	DIN1	I	Digital audio signal input terminal when recording mode
21	DOUT	O	Digital audio signal output terminal when playback mode
22	DATAI	I	Serial data input terminal Not used (fixed at “L”)
23	LRCKI	I	L/R sampling clock signal (44.1 kHz) input terminal Not used (fixed at “L”)
24	XBCKI	I	Bit clock signal (2.8224 MHz) input terminal Not used (fixed at “L”)
25	ADDT	I	Recording data input from the A/D, D/A converter (IC201)
26	DADT	O	Playback data output to the A/D, D/A converter (IC201)
27	LRCK	O	L/R sampling clock signal (44.1 kHz) output to the A/D, D/A converter (IC201)
28	XBCK	O	Bit clock signal (2.8224 MHz) output to the A/D, D/A converter (IC201)
29	FS256	O	Clock signal (11.2896 MHz) output terminal Not used (open)
30	DVDD	—	Power supply terminal (+3.3V) (digital system)
31 to 34	A03 to A00	O	Address signal output to the D-RAM (IC124)
35	A10	O	Address signal output to the external D-RAM Not used (open)
36 to 40	A04 to A08	O	Address signal output to the D-RAM (IC124)
41	A11	O	Address signal output to the external D-RAM Not used (open)
42	DVSS	—	Ground terminal (digital system)
43	XOE	O	Output enable signal output to the D-RAM (IC124) “L” active
44	XCAS	O	Column address strobe signal output to the D-RAM (IC124) “L” active

* I (S) stands for schmitt input, I (A) for analog input, O (3) for 3-state output, and O (A) for analog output in the column I/O.

Pin No.	Pin Name	I/O	Description
45	A09	O	Address signal output to the D-RAM (IC124)
46	XRAS	O	Row address strobe signal output to the D-RAM (IC124) "L" active
47	XWE	O	Write enable signal output to the D-RAM (IC124) "L" active
48	D1	I/O	Two-way data bus with the D-RAM (IC124)
49	D0	I/O	
50	D2	I/O	
51	D3	I/O	
52	MVCI	I (S)	Digital in PLL oscillation input from the external VCO Not used (fixed at "L")
53	ASYO	O	Playback EFM full-swing output terminal
54	ASYI	I (A)	Playback EFM asymmetry comparator voltage input terminal
55	AVDD	—	Power supply terminal (+3.3V) (analog system)
56	BIAS	I (A)	Playback EFM asymmetry circuit constant current input terminal
57	RFI	I (A)	Playback EFM RF signal input from the CXA2523AR (IC101)
58	AVSS	—	Ground terminal (analog system)
59	PCO	O (3)	Phase comparison output for master clock of the recording/playback EFM master PLL
60	FILI	I (A)	Filter input for master clock of the recording/playback master PLL
61	FILO	O (A)	Filter output for master clock of the recording/playback master PLL
62	CLTV	I (A)	Internal VCO control voltage input of the recording/playback master PLL
63	PEAK	I (A)	Light amount signal (RF/ABCD) peak hold input from the CXA2523AR (IC101)
64	BOTM	I (A)	Light amount signal (RF/ABCD) bottom hold input from the CXA2523AR (IC101)
65	ABCD	I (A)	Light amount signal (ABCD) input from the CXA2523AR (IC101)
66	FE	I (A)	Focus error signal input from the CXA2523AR (IC101)
67	AUX1	I (A)	Auxiliary signal (I ₃ signal/temperature signal) input from the CXA2523AR (IC101)
68	VC	I (A)	Middle point voltage (+1.65V) input from the CXA2523AR (IC101)
69	ADIO	O (A)	Monitor output of the A/D converter input signal Not used (open)
70	AVDD	—	Power supply terminal (+3.3V) (analog system)
71	ADRT	I (A)	A/D converter operational range upper limit voltage input terminal (fixed at "H" in this set)
72	ADRB	I (A)	A/D converter operational range lower limit voltage input terminal (fixed at "L" in this set)
73	AVSS	—	Ground terminal (analog system)
74	SE	I (A)	Sled error signal input from the CXA2523AR (IC101)
75	TE	I (A)	Tracking error signal input from the CXA2523AR (IC101)
76	DCHG	I (A)	Connected to the +3.3V power supply
77	TEST4	I	Input terminal for the test Not used (fixed at "H")
78	ADFG	I (S)	ADIP duplex FM signal (22.05 kHz ± 1 kHz) input from the CXA2523AR (IC101)
79	F0CNT	O	Filter f0 control signal output to the CXA2523AR (IC101)
80	XLRF	O	Serial data latch pulse signal output to the CXA2523AR (IC101)
81	CKRF	O	Serial data transfer clock signal output to the CXA2523AR (IC101)
82	DTRF	O	Writing serial data output to the CXA2523AR (IC101)
83	APCREF	O	Control signal output to the reference voltage generator circuit for the laser automatic power control
84	TEST0	O	Input terminal for the test Not used (open)
85	TRDR	O	Tracking servo drive PWM signal (–) output to the BH6511FS (IC152)
86	TFDR	O	Tracking servo drive PWM signal (+) output to the BH6511FS (IC152)
87	DVDD	—	Power supply terminal (+3.3V) (digital system)
88	FFDR	O	Focus servo drive PWM signal (+) output to the BH6511FS (IC152)

* I (S) stands for schmitt input, I (A) for analog input, O (3) for 3-state output, and O (A) for analog output in the column I/O.

Pin No.	Pin Name	I/O	Description
89	FRDR	O	Focus servo drive PWM signal (-) output to the BH6511FS (IC152)
90	FS4	O	Clock signal (176.4 kHz) output terminal (X'tal system) Not used (open)
91	SRDR	O	Sled servo drive PWM signal (-) output to the BH6511FS (IC152)
92	SFDR	O	Sled servo drive PWM signal (+) output to the BH6511FS (IC152)
93	SPRD	O	Spindle servo drive PWM signal (-) output to the BH6511FS (IC152)
94	SPFD	O	Spindle servo drive PWM signal (+) output to the BH6511FS (IC152)
95	FGIN	I (S)	FG signal input terminal Not used (fixed at "L")
96	TEST1	I	Input terminal for the test (fixed at "L")
97	TEST2	I	
98	TEST3	I	
99	DVSS	—	Ground terminal (digital system)
100	EFMO	O	EFM signal output to the overwrite head driver (IC181) when recording mode

* I (S) stands for schmitt input, I (A) for analog input, O (3) for 3-state output, and O (A) for analog output in the column I/O.

• MD DIGITAL BOARD IC316 M30624MG-A16FP (MD MECHANISM CONTROLLER)

Pin No.	Pin Name	I/O	Description
1	WMOUT	O	Serial data output to the equipment connected to other unit Not used (open)
2	WMCLK	I	Serial data transfer clock signal input from the equipment connected to other unit Not used (fixed at "L")
3	LEVEL-L	O	Left channel level output to the master controller (IC501)
4	LEVEL-R	O	Right channel level output to the master controller (IC501)
5	LEDDATA	O	Serial data output terminal for the LED driver Not used (open)
6	—	O	Not used (open)
7	LEDCLK	O	Serial data transfer clock signal output terminal for the LED driver Not used (open)
8	BYTE	I	External data bus line byte selection signal input "L": 16 bit, "H": 8 bit (fixed at "L")
9	CNVSS	—	Ground terminal
10	XIN-T	I	Sub system clock input terminal (32.768 kHz) Not used (fixed at "L")
11	XOUT-T	O	Sub system clock output terminal (32.768 kHz) Not used (open)
12	S.RST	I	System reset signal input from the reset signal generator (IC931) "L": reset For several hundreds msec. after the power supply rises, "L" is input, then it changes to "H"
13	XOUT	O	Main system clock output terminal (10 MHz)
14	GND	—	Ground terminal
15	XIN	I	Main system clock input terminal (10 MHz)
16	3.3V	—	Power supply terminal (+3.3V)
17	NMI	I	Non-maskable interrupt input terminal (fixed at "H" in this set)
18	P.DOWN	I	Power down detection signal input terminal "L": power down, normally: "H"
19	WMSYNC	I	Sync signal input from the equipment connected to other unit Not used (fixed at "L")
20	I2CBUSY	O	Busy signal output for the I2C bus "L" active Not used (pull up)
21	L3CLK	O	L3 bus data transfer clock signal output to the A/D, D/A converter (IC201)
22	L3DATA	O	L3 bus data output to the A/D, D/A converter (IC201)
23	—	O	Not used (open)
24	ELEUP	O	Mini-disc elevator up/down motor control signal output terminal "H" active Not used (open)
25	—	O	Not used (open)
26	ELEDOWN	O	Mini-disc elevator up/down motor control signal output terminal "H" active Not used (open)
27	SQSY	I	Subcode Q sync (SCOR) input from the CXD2654R (IC121) "L" is input every 13.3 msec Almost all, "H" is input
28	RESET SW	I	Reset switch input terminal "L": reset Not used (fixed at "L")
29	I2CCLK	I/O	Shift clock signal input/output terminal for the I2C bus
30	I2CDATA	I/O	Serial data input/output terminal for the I2C bus
31	FLDATA	O	Display serial data output terminal Not used (open)
32	—	O	Not used (open)
33	FLCLK	O	Display serial data transfer clock signal output terminal Not used (open)
34	FLCS	O	Display serial chip select signal output terminal "L" active Not used (open)
35	SWDT	O	Writing data output to the CXD2654R (IC121)
36	SRDT	I	Reading data input from the CXD2654R (IC121)
37	SCLK	O	Serial clock signal output to the CXD2654R (IC121)
38	OPTSEL0	O	Selection signal output for the optical input signal Not used (open)
39	SENSOR	I	Elevator position detect sensor input terminal Not used (fixed at "L")
40	SENSOR2	I	Elevator position detect sensor input terminal Not used (fixed at "L")
41	HEADDOWN	O	Over write head up/down motor control signal output terminal "H" active Not used (open)

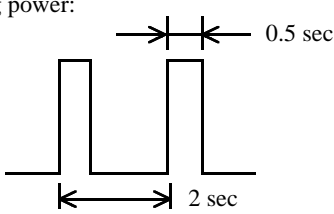
Pin No.	Pin Name	I/O	Description
42	HEADUP	O	Over write head up/down motor control signal output terminal “H” active Not used (open)
43	JOG0	I	Jog dial pulse input terminal (A phase input) Not used (open)
44	JOG1	I	Jog dial pulse input terminal (B phase input) Not used (open)
45	WMINV	O	Clock signal phase inversion control signal output to the equipment connected to other unit Not used (open)
46	LEDLAT	O	Serial data latch pulse output to the LED driver “L” active Not used (pull down)
47	OPTSEL1	O	Selection signal output terminal for digital signal Not used (open)
48	DARST	O	Reset signal output terminal “L”: reset Not used (open)
49	MUTE	O	Audio line muting control signal output terminal “L”: line muting on Not used (open)
50	STB	O	Power control strobe signal output for the external device “L”: standby mode, “H”: power on Not used (open)
51	CHACK-IN	I	Detection input from the disc loading in detect switch (S573) “L”: disc chucking, others: “H” Not used
52	HOME	I	Detection input from the elevator home position detect switch “L”: home position, others: “H” Not used (fixed at “L”)
53	PACK-OUT	I	Detection input from the disc loading out detect switch (S602) “L”: loading out position, others: “H”
54	LDIN	O	Mini-disc loading motor control signal output to the motor driver (IC153) “H” active *1
55	LDOUT	O	Mini-disc loading motor control signal output to the motor driver (IC153) “H” active *1
56	LD-LOW	I	The loading motor drive voltage control signal output to the motor driver (IC153) “H” active Not used (open)
57	LDON	O	Laser diode on/off control signal output to the automatic power control circuit “H”: laser on
58	REFLECT	I	Detection input from the disc reflection rate detect switch (S102-1) “L”: high reflection rate disc, “H”: low reflection rate disc
59	PROTECT	I	Rec-proof claw detect input from the protect detect switch (S102-2) “H”: write protect
60	PB-P	I	Detection input from the playback position detect switch (S604) “L” active
61	REC/PB	O	Not used (open)
62	3.3V	—	Power supply terminal (+3.3V)
63	LIMIT-IN	I	Detection input from the sled limit-in detect switch (S101) The optical pick-up is inner position when “L”
64	GND	—	Ground terminal
65	MOD	O	Laser modulation select signal output to the HF module switch circuit Playback power: “H”, Stop: “L”, Recording power: 

*1 Mini-disc loading motor (M903) control

Terminal \ Mode	Loading	Eject	Stop	Brake
LDIN (pin 54)	“H”	“L”	“L”	“H”
LDOUT (pin 55)	“L”	“H”	“L”	“H”

Pin No.	Pin Name	I/O	Description
66	XLATCH	O	Serial data latch pulse signal output to the CXD2654R (IC121)
67	WRPWR	O	Laser power select signal output to the CXD2654R (IC121) and HF module switch circuit “L”: playback mode, “H”: recording mode
68	LOADING SEL: L	I	Setting terminal for the loading control method “H”: not used IN switch (fixed at “L”)
69	L3MODE	O	L3 bus mode control signal output to the A/D, D/A converter (IC201)
70, 71	—	I	Not used (fixed at “H”)
72	SCTX	O	Recording data output enable signal output to the CXD2654R (IC121) and over write head driver (IC181) Writing data transmission timing output (Also serves as the magnetic head on/off output)
73	XINT	I	Interrupt status input from the CXD2654R (IC121)
74	REC-P	O	Detection input from the recording position detect switch (S601) “L”: recording position
75	DQSY	I	Digital In U-bit CD format subcode Q sync (SCOR) input from the CXD2654R (IC121) “L” is input every 13.3 msec Almost all, “H” is input
76	—	I	Not used (open)
77	DIGRST	O	Reset signal output to the CXD2654R (IC121) and BH6511FS (IC152) “L”: reset
78	SENS	I	Internal status (SENSE) input from the CXD2654R (IC121)
79	MNT3	I	Spindle servo lock status monitor signal input from the CXD2654R (IC121)
80	MNT2	I	Busy signal input from the CXD2654R (IC121)
81	MNT1	I	Track jump detection signal input from the CXD2654R (IC121)
82	MNT0	I	Focus OK signal input from the CXD2654R (IC121) “H” is input when focus is on (“L”: NG)
83	SENSOR SW	O	Control signal output for the sensor gain selection Not used (fixed at “L”)
84	DISK5	I	Detection input from the disc detect switch “L”: disc is set Not used (fixed at “L”)
85	DISK1	I	Detection input from the disc detect switch “L”: disc is set Not used (fixed at “L”)
86	DISK2	I	Detection input from the disc detect switch “L”: disc is set Not used (fixed at “L”)
87	SCL	O	Serial clock signal output to the EEPROM (IC171)
88	SDA	I/O	Two-way data bus with the EEPROM (IC171)
89	DISK4	I	Detection input from the disc detect switch “L”: disc is set Not used (fixed at “L”)
90	DISK3	I	Detection input from the disc detect switch “L”: disc is set Not used (fixed at “L”)
91	HEADSW- DOWN	I	Detection input from the over write head down position detect switch “L”: down position Not used (fixed at “L”)
92	HEADSW-UP	I	Detection input from the over write head up position detect switch “L”: up position Not used (fixed at “L”)
93 to 95	KEY3 to KEY1	I	Key input terminal (A/D input) Not used (fixed at “H”)
96	AVSS	—	Ground terminal (for A/D converter)
97	KEY0	I	Key input terminal (A/D input) Not used (fixed at “H”)
98	VREF	I	Reference voltage (+3.3V) input terminal (for A/D converter)
99	+3.3V	—	Power supply terminal (+3.3V)
100	WMIN	I	Serial data input from the equipment connected to other unit Not used (fixed at “L”)

• MAIN BOARD IC501 M30620MCA-A51FP (MASTER CONTROLLER)

Pin No.	Pin Name	I/O	Description
1	STKPOWER	O	Power amplifier (IC801) on/off selection signal output terminal "H": power amplifier on
2	P	O	Power on/off control signal output terminal Not used (open)
3	F-RY	O	Speakers on/off relay (RY881) drive signal output terminal "H": speakers on
4	R-RY	O	Rear speakers on/off relay drive signal output terminal "H": speakers on Not used (open)
5	CD-POWER	O	Power on/off control signal output for the CD servo section "L": standby, "H": power on
6	TA-MUTE	O	Line muting on/off signal output terminal "L": muting on
7	DBFB-H	O	H/L selection signal output terminal for DBFB Not used (open)
8	BYTE	I	External data bus line byte selection signal input "L": 16 bits, "H": 8 bits Not used (fixed at "L")
9	CNVSS	—	Ground terminal
10	SUBXIN	I	Sub system clock input terminal (32.768 kHz)
11	SUBXOUT	O	Sub system clock output terminal (32.768 kHz)
12	RESET	I	System reset signal input from the reset signal generator (IC941) "L": reset For several hundreds msec. after the power supply rises, "L" is input, then it changes to "H"
13	XOUT	O	Main system clock output terminal (16 MHz)
14	VSS	—	Ground terminal
15	XIN	I	Main system clock input terminal (16 MHz)
16	VCC	—	Power supply terminal (+5V)
17	NMI	I	Non-maskable interrupt input terminal Fixed at "H" in this set
18	WAKE-UP	I	System wake up signal input terminal Not used (fixed at "L")
19	SCOR	I	Subcode sync (S0+S1) detection signal input from the CXD2587Q (IC101)
20	RDS-INT	I	Interrupt status input from the tuner pack Not used (open)
21	RDS-DATA	I	Serial data input from the tuner pack Not used (open)
22	AC-CUT	I	AC off detection signal input from the voltage detector (IC941) "L": AC off
23	PL-CLK	O	Serial data transfer clock signal output to pro-logic circuit Not used (open)
24	PL-DATA	O	Serial data output to pro-logic circuit Not used (open)
25	PL-LAT	O	Serial data latch pulse output to pro-logic circuit Not used (open)
26	TIMER-LED	O	LED drive signal output of the timer indicator Not used (open)
27	PROTECT-IN	I	Over load detection signal input for speaker output "L": over load
28	MD-RESET	O	MD reset signal output terminal Not used (open)
29	IIC-SCL	I/O	Shift clock signal input/output terminal for the IIC bus
30	IIC-DAT	I/O	Data input/output terminal for the IIC bus
31	TXD	—	Not used (fixed at "L")
32	SQ-DATA-IN	I	Subcode Q data input from the CXD2587Q (IC101)
33	SQ-CLK	O	Subcode Q data reading clock signal output to the CXD2587Q (IC101)
34	FL-RESET	O	Reset signal output to the FL driver (IC601) "L": reset
35	FL-DATA	O	Serial data output to the FL driver (IC601)
36	FL-CHIP SELECT	O	Chip select signal output to the FL driver (IC601) "L": active
37	FL-CLK	O	Serial data transfer clock signal output to the FL driver (IC601)
38	62LAT	O	Serial data latch pulse signal output to the M62428AFP (IC301)
39	STBY-LED	O	LED drive signal output of the standby indicator Not used (open)
40, 41	V-CINE	O	Not used (open)
42	FL-ON	O	FL power on/off control signal output terminal Not used (open)
43	POWER-ON	O	Standby relay drive signal output terminal "L": standby, "H": power on
44	B-FREQ	O	Not used (open)
45	FUNC-SEL1	O	Function selection signal output terminal Not used (open)

Pin No.	Pin Name	I/O	Description
46	OPT-SEL	O	Optical signal selection signal output terminal Not used (open)
47	62DATA	O	Serial data output to the M62428AFP (IC301)
48	62CLK	O	Serial data transfer clock signal output to the M62428AFP (IC301)
49	ST-MUTE	O	Tuner muting control signal output to the tuner pack "L": muting on
50	STEREO	I	FM stereo detection signal input from the tuner pack
51	TUNED	I	Tuning detection signal input from the tuner pack
52	ST-CE	O	PLL chip enable signal output to the tuner pack
53	ST-DOUT	O	PLL serial data output to the tuner pack
54	ST-DIN	I	PLL serial data input from the tuner pack
55	ST-CLK	O	PLL serial data transfer clock signal output to the tuner pack
56	SENSE	I	Internal status detection monitor input from the CXD2587Q (IC101)
57	HOLD	O	Automatic power control hold signal output to the CXA2568M (IC103)
58	CD-LAT	O	Serial data latch pulse output to the CXD2587Q (IC101)
59	CD-RESET	O	Reset signal output to the CXD2587Q (IC101) and BA5974FP (IC102)
60	DISC-SENS	I	Detection input from the disc in detect switch Not used (fixed at "H")
61	TABLE-SENS	I	Detection input from the disc tray detect switch Not used (fixed at "H")
62	VCC	—	Power supply terminal (+5V)
63	TABLE-L	O	Disc tray open/close motor drive signal output terminal Not used (open)
64	VSS	—	Ground terminal
65	TABLE-R	O	Disc tray open/close motor drive signal output terminal Not used (open)
66	LOAD-OUT	O	CD loading motor control signal output to the motor driver (IC171)
67	LOAD-IN	O	CD loading motor control signal output to the motor driver (IC171)
68	UP-SW	I	Not used (fixed at "L")
69	DISC-LED	I	Not used (fixed at "L")
70	IN-SW	I	Detection input from the CD disc tray open/close detect switch (S1) "L": CD disc tray close
71	OUT-SW	I	Detection input from the CD disc tray open/close detect switch (S1) "L": CD disc tray open
72	LED	O	LED drive signal output of the CD playback indicator (D665 (green)) "L": LED on
73	LED	O	LED drive signal output of the MD disc in indicator (D664) "H": LED on
74	LED	O	LED drive signal output of the MD playback indicator (D661 (green)) "L": LED on
75	LED	O	LED drive signal output of the MD pause indicator (D661 (amber)) "L": LED on
76	LED	O	LED drive signal output of the CD playback indicator (D665 (amber)) "L": LED on
77	LED	O	LED drive signal output of the CD disc in indicator (D667) "H": LED on
78	LED	O	LED drive signal output of the MD recording indicator (D663) "H": LED on
79	STANDBY	O	LED drive signal output of the standby indicator (D668) "H": LED on
80	LED	O	LED drive signal output terminal Not used (open)
81	CD-DATA	O	Serial data output to the CXD2587Q (IC101)
82	CD-CLK	O	Serial data transfer clock signal output to the CXD2587Q (IC101)
83	REC OUT CONT	O	Muting on/off control signal output of tape output signal "L": muting on
84	JOGA	I	Jog dial pulse input from the rotary encoder A phase input Not used (open)
85	JOGB	I	Jog dial pulse input from the rotary encoder B phase input Not used (open)
86	VOL A	I	Jog dial pulse input from the rotary encoder (S601 VOLUME) A phase input
87	VOL B	I	Jog dial pulse input from the rotary encoder (S601 VOLUME) B phase input
88	SIRCS	I	Remote control signal input from the remote control receiver (IC602)
89	KEY0	I	Key input terminal (A/D input) S602 (I/⏏ key input)

Pin No.	Pin Name	I/O	Description
90	KEY1	I	Key input terminal (A/D input) S603 to 608 (CD□, CD▷□□, CD⊕, MD□, MD▷□□, MD⊕, keys input)
91	KEY2	I	Key input terminal (A/D input) S609 to 616 (FUNCTION, +▶▶▷▷□, TUNER/BAND, -◀◀◀◀◀◀, ● REC, CD-MD SYNC, STEREO/MONO REPEAT, TUNING MODE/PLAY MODE keys input)
92	MD-REC-R	I	R-ch level input from the MD mechanism controller (IC316)
93	HEADPHONE	I	Headphone detection signal input terminal “H”: headphone in
94	MD-REC-L	I	L-ch level input from the MD mechanism controller (IC316)
95	MODEL-IN	I	Model destination setting terminal
96	AG	—	Ground terminal
97	SPEC-IN	I	Model specification setting terminal
98	VREF	I	Reference voltage (+5V) input terminal
99	AVCC	—	Power supply terminal (+5V)
100	TEST	—	Test setting terminal (fixed at “L”)

SECTION 7 EXPLODED VIEWS

NOTE:

- -XX and -X mean standardized parts, so they may have some difference from the original one.

- Color Indication of Appearance Parts

Example:

KNOB, BALANCE (WHITE) . . . (RED)

↑
↑
 Parts Color Cabinet's Color

- Abbreviation

HK : Hong Kong model TW : Taiwan model

KR : Korean model

- Items marked “*” are not stocked since they are seldom required for routine service. Some delay should be anticipated when ordering these items.

- The mechanical parts with no reference number in the exploded views are not supplied.

- Hardware (# mark) list and accessories and packing materials are given in the last of the electrical parts list.

The components identified by mark Δ or dotted line with mark Δ are critical for safety. Replace only with part number specified.

(1) CASE, FRONT PANEL SECTION

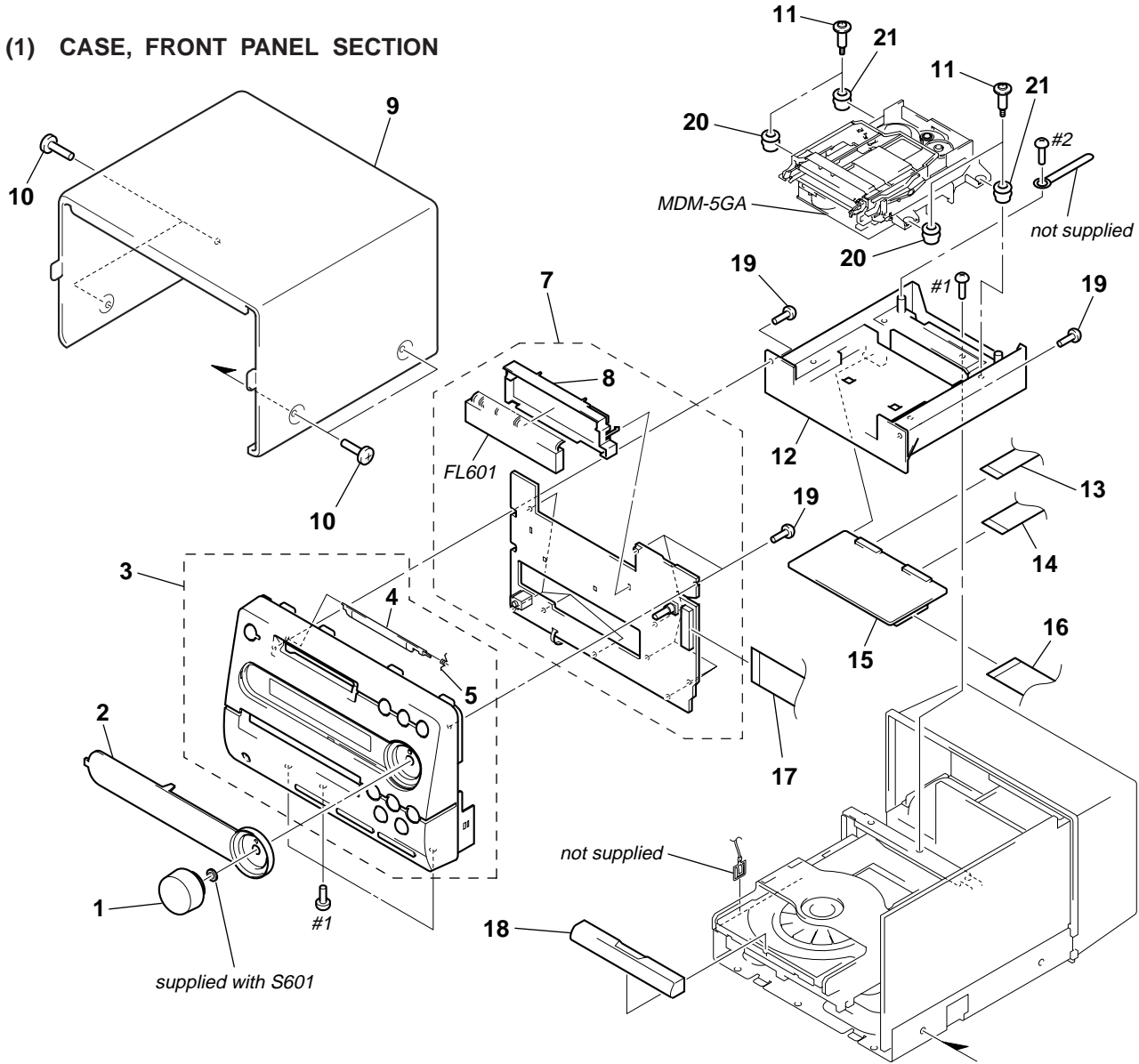

Ref. No.	Part No.	Description	Remark	Ref. No.	Part No.	Description	Remark
1	4-228-468-01	KNOB (VOL)		12	4-221-097-02	BRACKET (MDM)	
2	4-228-471-01	PLATE (FL, INDICATION (SILVER)		13	1-777-240-11	WIRE (FLAT TYPE) (21 CORE)	
2	4-228-471-11	PLATE (FL, INDICATION (WHITE)		14	1-791-211-11	WIRE (FLAT TYPE) (23 CORE)	
3	X-4952-957-4	PANEL ASSY, FRONT (S) (SILVER)		15	A-4475-917-A	MD DIGITAL BOARD, COMPLETE	
3	X-4952-996-4	PANEL ASSY (W), FRONT (WHITE)		16	1-773-212-11	WIRE (FLAT TYPE) (25 CORE)	
4	4-216-729-71	LID (CARTRIDGE)		17	1-792-756-11	WIRE (FLAT TYPE) (29 CORE)	
5	4-223-771-21	SPRING (LID)		18	4-228-469-01	PANEL, LOADING (SILVER)	
7	A-4475-916-A	PANEL BOARD, COMPLETE		18	4-228-469-11	PANEL, LOADING (WHITE)	
8	4-212-590-22	HOLDER (FL)		19	4-951-620-01	SCREW (2.6X8), +BVTP	
* 9	4-228-798-41	CASE (SILVER)		20	4-996-223-01	INSULATOR (F) (BLACK)	
* 9	4-228-798-51	CASE (WHITE)		21	4-999-347-01	INSULATOR (R) (GREEN)	
10	3-363-099-11	SCREW (CASE 3 TP2)		FL601	1-517-985-11	INDICATOR TUBE, FLUORESCENT	
11	4-212-589-01	SCREW (+BVTPWH M3), STEP					

(2) CHASSIS SECTION

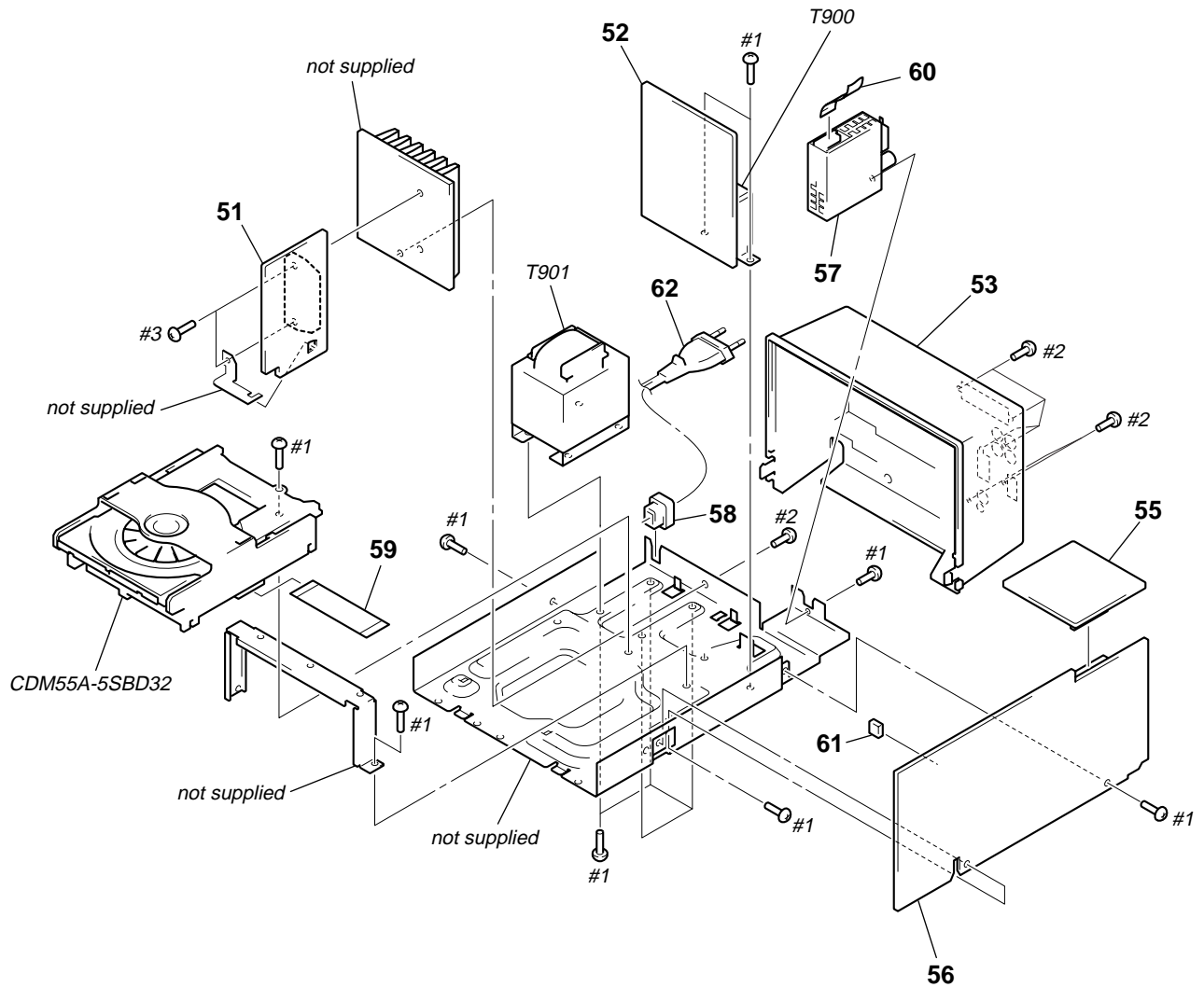

The components identified by mark Δ or dotted line with mark Δ are critical for safety. Replace only with part number specified.

Ref. No.	Part No.	Description	Remark	Ref. No.	Part No.	Description	Remark
51	A-4475-921-A	AMP BOARD, COMPLETE (HK, TW)		57	1-693-473-41	TUNER (FM/AM TUNER UNIT) (HK, KR)	
51	A-4475-925-A	AMP BOARD, COMPLETE (KR)		58	3-703-244-00	BUSHING (2104), CORD	
52	A-4475-920-A	POWER BOARD, COMPLETE (HK, TW)		59	1-773-115-11	WIRE (FLAT TYPE) (19 CORE)	
52	A-4475-924-A	POWER BOARD, COMPLETE (KR)		60	1-773-006-11	WIRE (FLAT TYPE) (15 CORE)	
53	X-4953-470-1	PANEL ASSY, BACK		61	1-569-972-21	SOCKET, SHORT 2P	
55	1-674-628-12	SP BOARD		Δ 62	1-769-079-21	CORD, POWER (KR)	
56	A-4475-919-A	MAIN BOARD, COMPLETE (HK, TW)		Δ 62	1-769-744-11	CORD, POWER (HK, TW)	
56	A-4475-923-A	MAIN BOARD, COMPLETE (KR)		Δ T900	1-433-970-11	TRANSFORMER, POWER	
57	1-693-473-31	TUNER (FM/AM TUNER UNIT) (TW)		Δ T901	1-433-966-11	TRANSFORMER, POWER	

**(3) MD MECHANISM DECK SECTION
(MDM-5GA)**

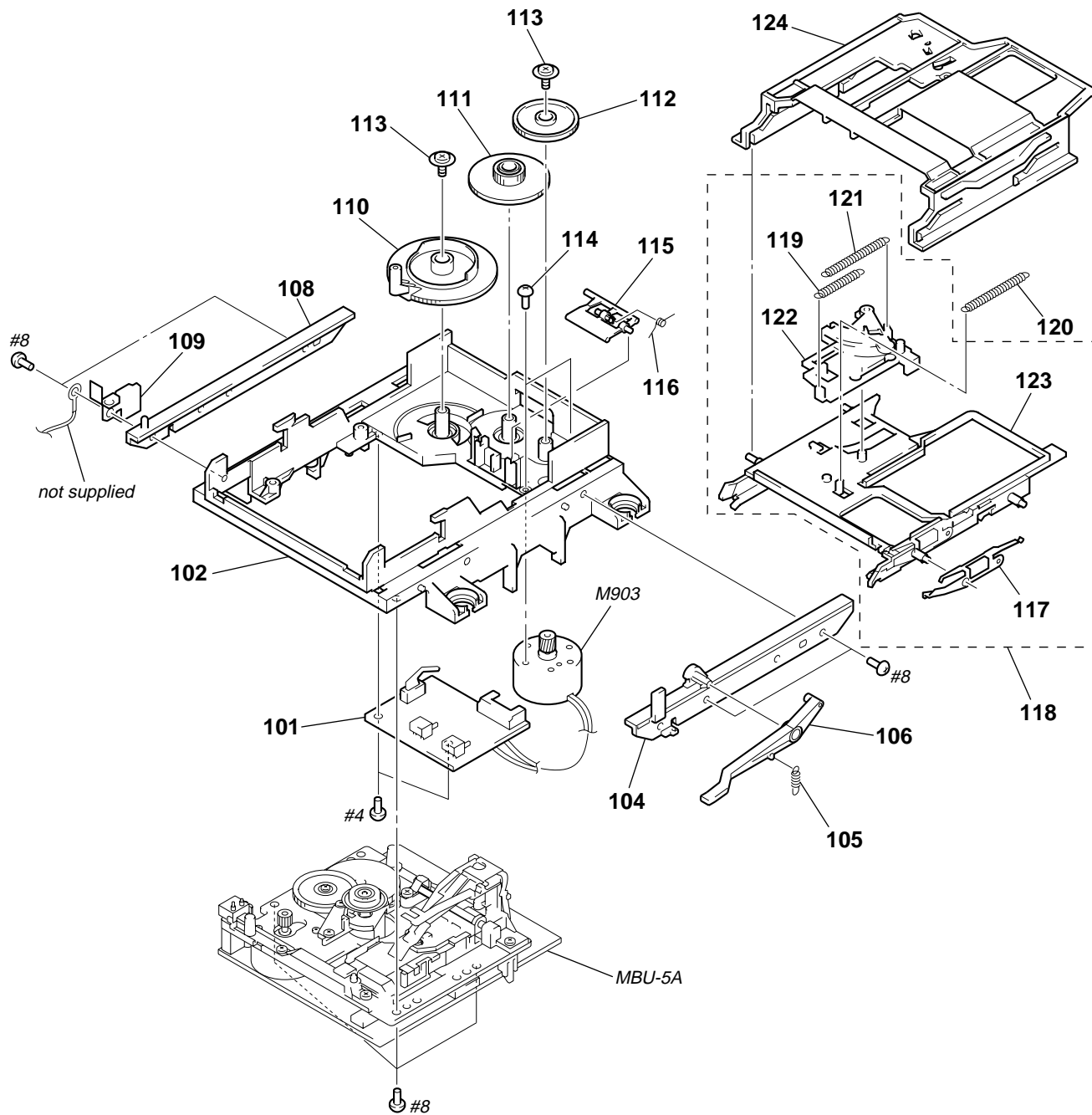

Ref. No.	Part No.	Description	Remark	Ref. No.	Part No.	Description	Remark
* 101	1-671-115-21	SW BOARD		115	4-996-227-14	LEVER (HEAD)	
* 102	4-996-217-01	CHASSIS		116	4-996-229-01	SPRING (HEAD LEVER), TORSION	
* 104	4-996-218-01	BRACKET (GUIDE R)		117	4-998-763-14	SPRING (SHUTTER), LEAF	
105	4-996-277-01	SPRING (O/C), TENSION		118	A-4680-200-G	HOLDER COMPLETE ASSY	
106	4-996-226-01	LEVER (O/C)		119	4-996-214-01	SPRING (SLIDER), TENSION	
* 108	4-996-225-01	BRACKET (GUIDE L)		120	4-996-216-01	SPRING (HOLDER), TENSION	
109	4-988-466-11	SPRING (ELECTROSTATIC), LEAF		121	4-996-215-11	SPRING (LOCK LEVER), TENSION	
110	4-996-219-01	GEAR (CAM GEAR)		122	X-4949-668-3	SLIDER ASSY	
111	4-996-220-01	GEAR (A)		123	X-4949-667-4	HOLDER ASSY	
112	4-996-221-01	GEAR (B)		* 124	4-996-211-11	SLIDER (CAM)	
113	4-933-134-01	SCREW (+PTPWH M2.6X6)		M903	X-4949-264-1	MOTOR ASSY, LOADING (MD)	
114	4-996-224-01	SCREW (1.7X3), +PWH					

**(4) MD BASE UNIT SECTION
(MBU-5A)**

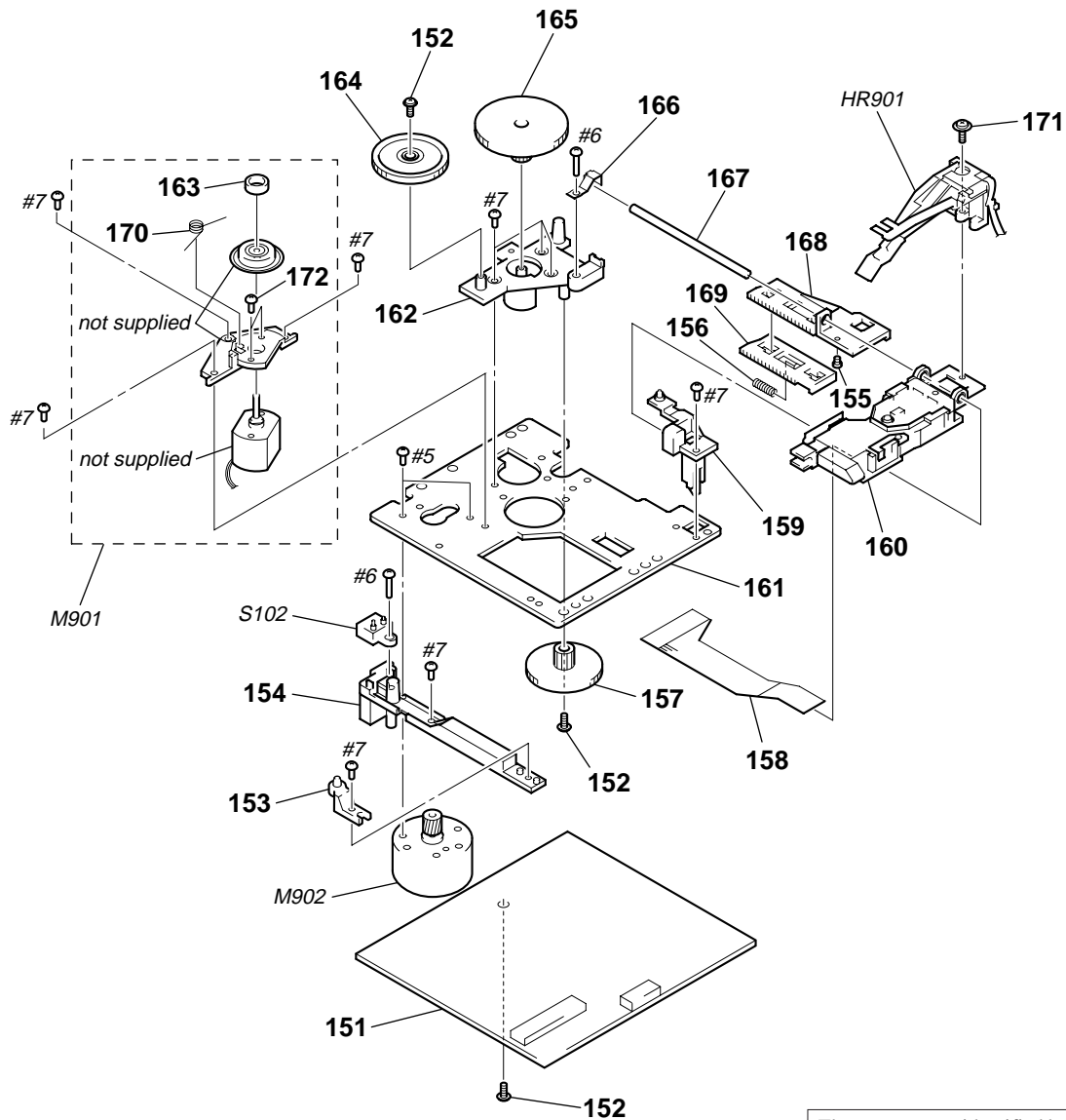

The components identified by mark \triangle or dotted line with mark \triangle are critical for safety. Replace only with part number specified.

Ref. No.	Part No.	Description	Remark	Ref. No.	Part No.	Description	Remark
	151	A-4699-893-A	BD (MD) BOARD, COMPLETE		165	4-996-261-01	GEAR (SL-B)
	152	3-372-761-01	SCREW (M1.7), TAPPING		166	4-996-264-01	SPRING (SHAFT), LEAF
*	153	4-996-267-01	BASE (BU-D)		167	4-996-265-01	SHAFT, MAIN
*	154	4-996-255-01	BASE (BU-C)		168	4-996-256-11	SL (BASE)
	155	4-900-590-01	SCREW, PRECISION SMALL		169	4-996-257-01	RACK (SL)
	156	4-996-258-01	SPRING, COMPRESSION		170	4-996-263-01	SPRING (CLV), TORSION
	157	4-996-262-01	GEAR (SL-C)		171	4-988-560-01	SCREW (+P 1.7X6)
*	158	1-667-954-11	PC BOARD, FLEXIBLE		172	4-211-036-01	SCREW (1.7X2.5), +PWH
*	159	4-210-664-11	BASE (BU-A)		HR901	1-500-502-11	HEAD, OVER WRITE
\triangle	160	A-4672-541-A	OPTICAL PICK-UP KMS-260B/S1NP		M901	A-4672-475-A	MOTOR ASSY, SPINDLE (MD)
*	161	4-996-252-01	CHASSIS, BU		M902	A-4672-474-A	MOTOR ASSY, SLED (MD)
*	162	4-996-254-01	BASE (BU-B)		S102	1-762-148-21	SWITCH, PUSH (2 KEY) (PROTECT/REFLECT RATE DETECT)
	163	4-967-688-11	MAGNET, ABSORPTION				
	164	4-996-260-01	GEAR (SL-A)				

(5) CD MECHANISM DECK SECTION
(CDM55A-5SBD32)

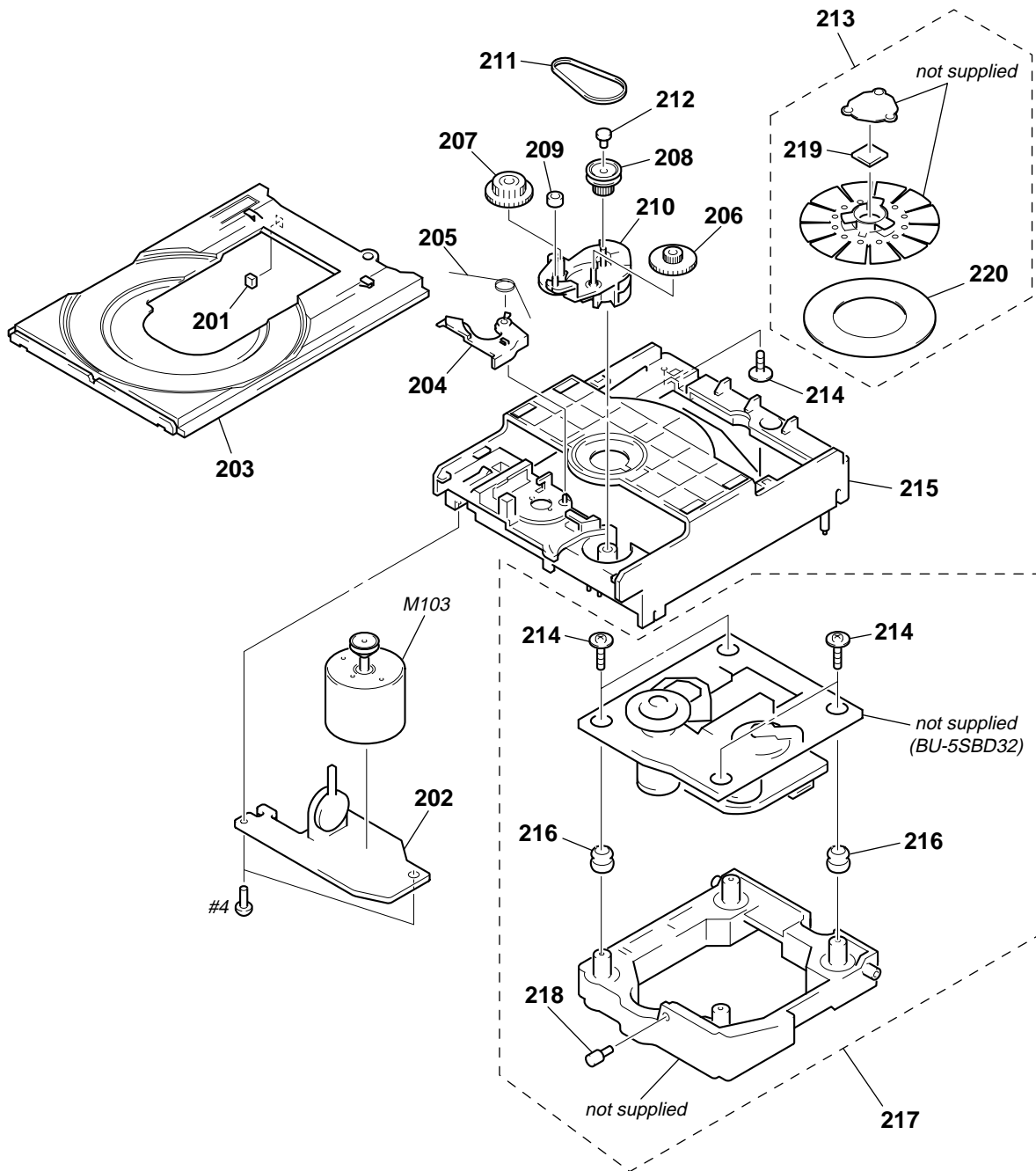

Ref. No.	Part No.	Description	Remark	Ref. No.	Part No.	Description	Remark
201	4-925-315-31	DAMPER		212	4-221-916-01	BUSHING	
202	1-674-336-12	LOADING BOARD		213	A-4672-773-A	PULLEY (AT) ASSY	
203	4-220-231-01	TRAY (CDM)		214	4-985-672-01	SCREW (+PTPWH M2.6), FLOATING	
204	4-220-229-01	LEVER (SW)		215	4-220-230-01	CHASSIS	
205	4-220-239-01	SPRING, TORSION		216	4-959-996-01	SPRING (932), COMPRESSION	
206	4-220-237-01	GEAR (A)		217	A-4672-772-A	HOLDER (BU) ASSY	
207	4-220-238-01	GEAR (B)		218	4-221-817-02	SHAFT (BU)	
208	4-220-234-01	PULLEY (LDG)		219	4-224-629-11	SHEET (AT)	
209	4-221-815-01	ROLLER		220	4-220-951-02	SHEET (KH)	
210	4-220-233-01	CAM (CDM55)		M103	A-4672-771-A	MOTOR (LD) ASSY (LOADING) (CD)	
211	4-221-816-01	BELT (CDM55)					

(6) CD BASE UNIT SECTION
(BU-5SBD32)

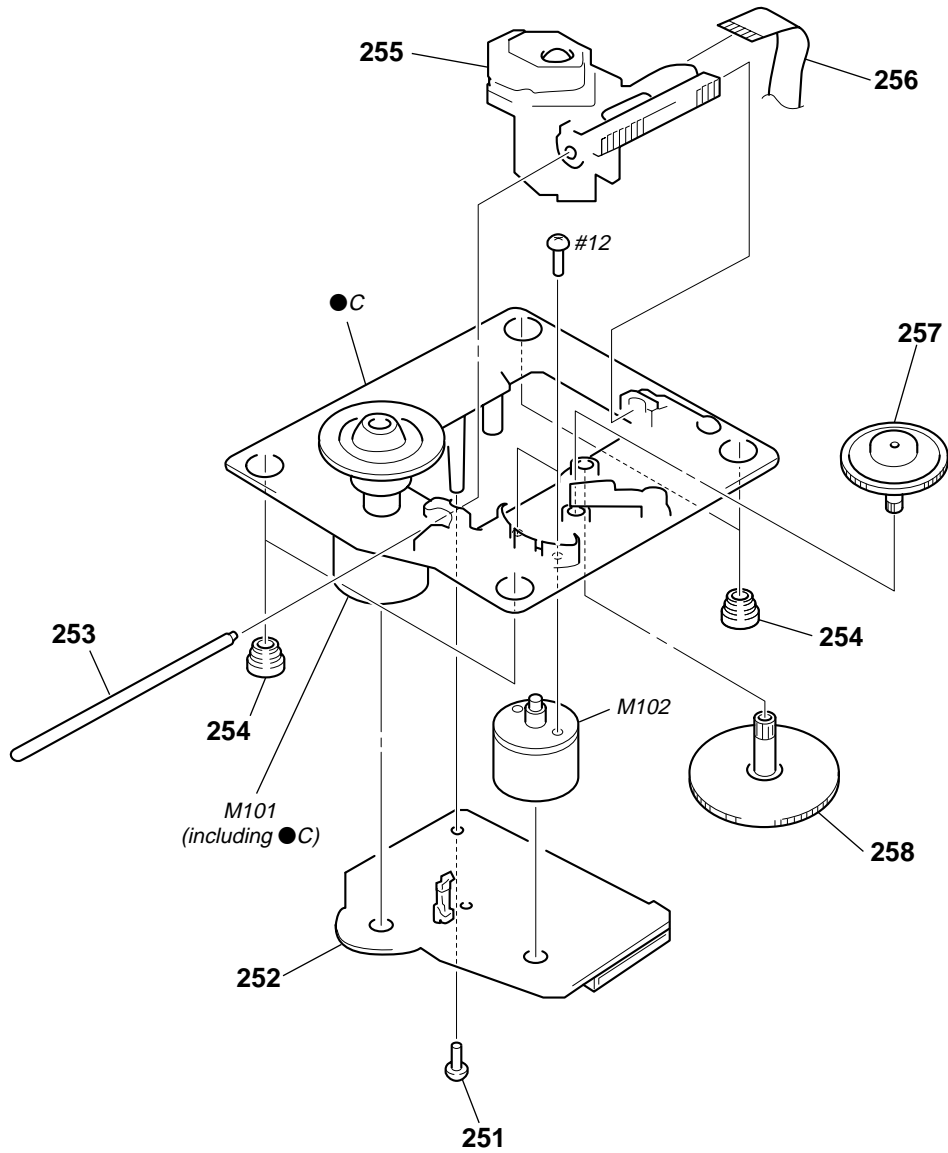

The components identified by mark \triangle or dotted line with mark \triangle are critical for safety. Replace only with part number specified.

Ref. No.	Part No.	Description	Remark	Ref. No.	Part No.	Description	Remark
251	4-951-620-01	SCREW (2.6X8), +BVTP		256	1-782-817-11	WIRE (FLAT TYPE) (16 CORE)	
* 252	A-4724-375-A	BD (CD) BOARD, COMPLETE		257	4-917-567-01	GEAR (M)	
253	4-917-565-01	SHAFT, SLED		258	4-917-564-01	GEAR (P), FLATNESS	
254	4-951-940-01	INSULATOR (BU)		M101	X-4952-989-1	BASE (BU-5S) ASSY (CD)	
\triangle 255	8-820-113-01	OPTICAL PICK-UP KSS-213BH/Z-NP		M102	X-4917-504-1	MOTOR ASSY (SLED) (CD)	

SECTION 8 ELECTRICAL PARTS LIST

NOTE:

- Due to standardization, replacements in the parts list may be different from the parts specified in the diagrams or the components used on the set.
- -XX and -X mean standardized parts, so they may have some difference from the original one.
- RESISTORS
All resistors are in ohms.
METAL: Metal-film resistor.
METAL OXIDE: Metal oxide-film resistor.
F: nonflammable
- Abbreviation
HK : Hong Kong model
KR : Korean model
TW : Taiwan model

- Items marked “*” are not stocked since they are seldom required for routine service. Some delay should be anticipated when ordering these items.
- SEMICONDUCTORS
In each case, u: μ , for example:
uA. . : μ A. . uPA. . : μ PA. .
uPB. . : μ PB. . uPC. . : μ PC. .
uPD. . : μ PD. .
- CAPACITORS
uF: μ F
- COILS
uH: μ H

The components identified by mark Δ or dotted line with mark Δ are critical for safety. Replace only with part number specified.

When indicating parts by reference number, please include the board.

Ref. No.	Part No.	Description	Remark	Ref. No.	Part No.	Description	Remark
	A-4475-921-A	AMP BOARD, COMPLETE (HK, TW)		D851	8-719-911-19	DIODE 1SS119-25	
	A-4475-925-A	AMP BOARD, COMPLETE (KR)		D852	8-719-911-19	DIODE 1SS119-25	

	11-533-293-11	FUSE HOLDER				< FUSE >	
		< CAPACITOR >		Δ F801	1-532-504-31	FUSE (T4AL/250V)	
				Δ F802	1-532-504-31	FUSE (T4AL/250V)	
						< IC >	
C801	1-124-721-11	ELECT	10uF 20% 50V				
C802	1-162-286-31	CERAMIC	220PF 10% 50V				
C803	1-126-964-11	ELECT	10uF 20% 50V	IC801	8-749-920-13	IC STK4132MK2	
C804	1-162-288-31	CERAMIC	330PF 10% 50V			< TRANSISTOR >	
C805	1-126-051-11	ELECT	47uF 20% 50V				
C806	1-126-051-11	ELECT	47uF 20% 50V	Q801	8-729-044-08	TRANSISTOR 2SD1915 (F)-T (TA). SO	
C807	1-136-495-11	FILM	0.068uF 5% 50V	Q802	8-729-620-05	TRANSISTOR 2SC2603-EF	
C808	1-136-495-11	FILM	0.068uF 5% 50V	Q841	8-729-900-80	TRANSISTOR DTC114ES	
C821	1-126-965-11	ELECT	22uF 20% 50V	Q851	8-729-044-08	TRANSISTOR 2SD1915 (F)-T (TA). SO	
C822	1-126-052-11	ELECT	100uF 20% 50V	Q852	8-729-620-05	TRANSISTOR 2SC2603-EF	
C823	1-136-165-00	FILM	0.1uF 5% 50V	Q871	8-729-119-76	TRANSISTOR 2SA1175-HFE	
C824	1-164-159-11	CERAMIC	0.1uF 50V	Q872	8-729-620-05	TRANSISTOR 2SC2603-EF	
C831	1-126-052-11	ELECT	100uF 20% 50V	Q873	8-729-620-05	TRANSISTOR 2SC2603-EF	
C832	1-136-165-00	FILM	0.1uF 5% 50V			< RESISTOR >	
C833	1-126-860-11	ELECT	3300uF 20% 35V				
C834	1-136-165-00	FILM	0.1uF 5% 50V	R801	1-249-421-11	CARBON 2.2K 5% 1/4W	
C835	1-126-860-11	ELECT	3300uF 20% 35V	R802	1-249-429-11	CARBON 10K 5% 1/4W	
C836	1-136-165-00	FILM	0.1uF 5% 50V	R803	1-249-437-11	CARBON 47K 5% 1/4W	
C841	1-126-960-11	ELECT	1uF 20% 50V	R804	1-249-437-11	CARBON 47K 5% 1/4W	
C851	1-124-721-11	ELECT	10uF 20% 50V	R805	1-249-417-11	CARBON 1K 5% 1/4W	
C852	1-162-286-31	CERAMIC	220PF 10% 50V	R806	1-249-437-11	CARBON 47K 5% 1/4W	
C853	1-126-964-11	ELECT	10uF 20% 50V	R807	1-260-103-11	CARBON 2.2K 5% 1/2W	
C854	1-162-288-31	CERAMIC	330PF 10% 50V	R808	1-260-103-11	CARBON 2.2K 5% 1/2W	
C855	1-126-051-11	ELECT	47uF 20% 50V	Δ R809	1-217-151-00	METAL 0.22 10% 2W F	
C856	1-126-051-11	ELECT	47uF 20% 50V	R810	1-249-417-11	CARBON 1K 5% 1/4W	
C857	1-136-495-11	FILM	0.068uF 5% 50V	R811	1-249-431-11	CARBON 15K 5% 1/4W	
C858	1-136-495-11	FILM	0.068uF 5% 50V	R812	1-260-076-11	CARBON 10 5% 1/2W	
C871	1-126-933-11	ELECT	100uF 20% 16V	Δ R821	1-212-881-11	FUSIBLE 100 5% 1/4W F	
		< CONNECTOR >		R822	1-260-328-11	CARBON 1K 5% 1/2W	
				R823	1-260-328-11	CARBON 1K 5% 1/2W	
CN801	1-770-731-11	CONNECTOR, BOARD TO BOARD 12P		R824	1-249-441-11	CARBON 100K 5% 1/4W	
* CN802	1-564-518-11	PLUG, CONNECTOR 3P		R825	1-249-433-11	CARBON 22K 5% 1/4W	
		< DIODE >		Δ R831	1-212-881-11	FUSIBLE 100 5% 1/4W F	
D801	8-719-911-19	DIODE 1SS119-25		R841	1-249-437-11	CARBON 47K 5% 1/4W	
D802	8-719-911-19	DIODE 1SS119-25		R842	1-249-437-11	CARBON 47K 5% 1/4W	
D832	8-719-028-23	DIODE D3SBA20-4101		R843	1-249-441-11	CARBON 100K 5% 1/4W	
				R844	1-247-807-31	CARBON 100 5% 1/4W	

Ref. No.	Part No.	Description	Remark	Ref. No.	Part No.	Description	Remark
R845	1-249-441-11	CARBON	100K 5% 1/4W	C157	1-163-009-11	CERAMIC CHIP 0.001uF 10% 50V	
R851	1-249-421-11	CARBON	2.2K 5% 1/4W	C159	1-163-019-00	CERAMIC CHIP 0.0068uF 10% 50V	
R852	1-249-429-11	CARBON	10K 5% 1/4W	C161	1-126-206-11	ELECT CHIP 100uF 20% 6.3V	
R853	1-249-437-11	CARBON	47K 5% 1/4W	C162	1-126-205-11	ELECT CHIP 47uF 20% 6.3V	
R854	1-249-437-11	CARBON	47K 5% 1/4W	C163	1-126-206-11	ELECT CHIP 100uF 20% 6.3V	
R855	1-249-417-11	CARBON	1K 5% 1/4W	C165	1-163-038-11	CERAMIC CHIP 0.1uF 25V	
R856	1-249-437-11	CARBON	47K 5% 1/4W	C167	1-163-235-11	CERAMIC CHIP 22PF 5% 50V	
R857	1-260-103-11	CARBON	2.2K 5% 1/2W	C168	1-163-235-11	CERAMIC CHIP 22PF 5% 50V	
R858	1-260-103-11	CARBON	2.2K 5% 1/2W	C171	1-163-009-11	CERAMIC CHIP 0.001uF 10% 50V	
△ R859	1-217-151-00	METAL	0.22 10% 2W F	C172	1-163-123-00	CERAMIC CHIP 180PF 5% 50V	
R860	1-249-417-11	CARBON	1K 5% 1/4W	C181	1-163-009-11	CERAMIC CHIP 0.001uF 10% 50V	
R861	1-249-431-11	CARBON	15K 5% 1/4W	C182	1-163-123-00	CERAMIC CHIP 180PF 5% 50V	
R862	1-260-076-11	CARBON	10 5% 1/2W			< CONNECTOR >	
R871	1-249-441-11	CARBON	100K 5% 1/4W	CN101	1-778-874-11	CONNECTOR, FFC (LIF (NON-ZIF)) 19P	
R872	1-249-429-11	CARBON	10K 5% 1/4W	CN102	1-777-937-11	CONNECTOR, FFC/FPC 16P	
R873	1-249-439-11	CARBON	68K 5% 1/4W			< FERRITE BEAD/SHORT >	
R874	1-249-437-11	CARBON	47K 5% 1/4W				

*	A-4724-375-A	BD (CD) BOARD, COMPLETE		FB101	1-500-445-21	FERRITE 0uH	
		*****		FB102	1-216-295-11	SHORT 0	
		< CAPACITOR >		FB103	1-500-445-21	FERRITE 0uH	
C101	1-163-005-11	CERAMIC CHIP	470PF 10% 50V	FB104	1-216-295-11	SHORT 0	
C102	1-164-004-11	CERAMIC CHIP	0.1uF 10% 25V			< IC >	
C103	1-163-005-11	CERAMIC CHIP	470PF 10% 50V	IC101	8-752-386-85	IC CXD2587Q	
C104	1-163-009-11	CERAMIC CHIP	0.001uF 10% 50V	IC102	8-759-549-28	IC BA5974FP-E2	
C108	1-164-004-11	CERAMIC CHIP	0.1uF 10% 25V	IC103	8-752-085-51	IC CXA2568M-T6	
C109	1-163-011-11	CERAMIC CHIP	0.0015uF 10% 50V			< TRANSISTOR >	
C110	1-164-182-11	CERAMIC CHIP	0.0033uF 10% 50V	Q101	8-729-010-08	TRANSISTOR MSB710-R	
C111	1-163-251-11	CERAMIC CHIP	100PF 5% 50V			< RESISTOR >	
C112	1-163-038-11	CERAMIC CHIP	0.1uF 25V	R101	1-216-077-00	RES-CHIP 15K 5% 1/10W	
C113	1-163-038-11	CERAMIC CHIP	0.1uF 25V	R102	1-216-097-11	RES-CHIP 100K 5% 1/10W	
C114	1-163-038-11	CERAMIC CHIP	0.1uF 25V	R103	1-216-077-00	RES-CHIP 15K 5% 1/10W	
C115	1-126-607-11	ELECT CHIP	47uF 20% 4V	R104	1-216-085-00	METAL CHIP 33K 5% 1/10W	
C116	1-126-607-11	ELECT CHIP	47uF 20% 4V	R105	1-216-073-00	METAL CHIP 10K 5% 1/10W	
C117	1-126-209-11	ELECT CHIP	100uF 20% 4V	R106	1-216-049-11	RES-CHIP 1K 5% 1/10W	
C118	1-163-009-11	CERAMIC CHIP	0.001uF 10% 50V	R107	1-216-073-00	METAL CHIP 10K 5% 1/10W	
C119	1-163-235-11	CERAMIC CHIP	22PF 5% 50V	R108	1-216-061-00	METAL CHIP 3.3K 5% 1/10W	
C121	1-163-038-11	CERAMIC CHIP	0.1uF 25V	R109	1-216-121-11	RES-CHIP 1M 5% 1/10W	
C122	1-126-206-11	ELECT CHIP	100uF 20% 6.3V	R110	1-216-025-11	RES-CHIP 100 5% 1/10W	
C123	1-163-021-11	CERAMIC CHIP	0.01uF 10% 50V	R111	1-216-121-11	RES-CHIP 1M 5% 1/10W	
C124	1-107-823-11	CERAMIC CHIP	0.47uF 10% 16V	R113	1-216-121-11	RES-CHIP 1M 5% 1/10W	
C125	1-163-038-11	CERAMIC CHIP	0.1uF 25V	R114	1-216-073-00	METAL CHIP 10K 5% 1/10W	
C126	1-163-038-11	CERAMIC CHIP	0.1uF 25V	R116	1-216-001-00	METAL CHIP 10 5% 1/10W	
C127	1-128-065-11	ELECT CHIP	68uF 20% 10V	R117	1-216-049-11	RES-CHIP 1K 5% 1/10W	
C128	1-163-038-11	CERAMIC CHIP	0.1uF 25V	R119	1-216-041-00	METAL CHIP 470 5% 1/10W	
C129	1-163-031-11	CERAMIC CHIP	0.01uF 50V	R123	1-216-073-00	METAL CHIP 10K 5% 1/10W	
C130	1-164-346-11	CERAMIC CHIP	1uF 16V	R124	1-216-097-11	RES-CHIP 100K 5% 1/10W	
C131	1-124-779-00	ELECT CHIP	10uF 20% 16V	R131	1-216-033-00	METAL CHIP 220 5% 1/10W	
C133	1-125-838-11	CERAMIC CHIP	2.2uF 10% 6.3V	R135	1-216-295-11	SHORT 0	
C140	1-164-346-11	CERAMIC CHIP	1uF 16V	R136	1-216-295-11	SHORT 0	
C141	1-164-346-11	CERAMIC CHIP	1uF 16V	R137	1-216-295-11	SHORT 0	
C143	1-163-038-11	CERAMIC CHIP	0.1uF 25V	R138	1-216-295-11	SHORT 0	
C151	1-163-235-11	CERAMIC CHIP	22PF 5% 50V	R143	1-216-103-00	METAL CHIP 180K 5% 1/10W	
C153	1-163-038-11	CERAMIC CHIP	0.1uF 25V	R144	1-216-103-00	METAL CHIP 180K 5% 1/10W	
C154	1-110-501-11	CERAMIC CHIP	0.33uF 10% 16V				
C156	1-163-235-11	CERAMIC CHIP	22PF 5% 50V				

The components identified by mark △ or dotted line with mark △ are critical for safety. Replace only with part number specified.

BD (CD)

BD (MD)

Ref. No.	Part No.	Description	Remark
R147	1-216-069-00	METAL CHIP 6.8K 5%	1/10W
R148	1-216-001-00	METAL CHIP 10 5%	1/10W
R149	1-216-001-00	METAL CHIP 10 5%	1/10W
R158	1-216-111-00	METAL CHIP 390K 5%	1/10W
R159	1-216-101-00	METAL CHIP 150K 5%	1/10W
R161	1-216-308-00	METAL CHIP 4.7 5%	1/10W
R162	1-216-101-00	METAL CHIP 150K 5%	1/10W
R171	1-216-078-00	RES-CHIP 16K 5%	1/10W
R172	1-216-073-00	METAL CHIP 10K 5%	1/10W
R173	1-216-077-00	RES-CHIP 15K 5%	1/10W
R181	1-216-078-00	RES-CHIP 16K 5%	1/10W
R182	1-216-073-00	METAL CHIP 10K 5%	1/10W
R183	1-216-077-00	RES-CHIP 15K 5%	1/10W
< NETWORK RESISTOR >			
RN101	1-233-576-11	RES, CHIP NETWORK 100	
RN102	1-233-576-11	RES, CHIP NETWORK 100	
< SWITCH >			
S101	1-572-085-11	SWITCH, LEAF (LIMIT)	
< VIBRATOR >			
X101	1-767-408-21	VIBRATOR, CRYSTAL (16.9344MHz)	

A-4699-893-A BD (MD) BOARD, COMPLETE			

< CAPACITOR >			
C101	1-125-822-11	TANTALUM 10uF 20%	10V
C102	1-163-038-11	CERAMIC CHIP 0.1uF	25V
C103	1-125-822-11	TANTALUM 10uF 20%	10V
C104	1-125-822-11	TANTALUM 10uF 20%	10V
C105	1-163-021-11	CERAMIC CHIP 0.01uF 10%	50V
C106	1-163-275-11	CERAMIC CHIP 0.001uF 5%	50V
C107	1-163-038-11	CERAMIC CHIP 0.1uF	25V
C108	1-163-038-11	CERAMIC CHIP 0.1uF	25V
C109	1-163-037-11	CERAMIC CHIP 0.022uF 10%	25V
C111	1-164-344-11	CERAMIC CHIP 0.068uF 10%	25V
C112	1-163-017-00	CERAMIC CHIP 0.0047uF 5%	50V
C113	1-109-982-11	CERAMIC CHIP 1uF 10%	10V
C115	1-164-489-11	CERAMIC CHIP 0.22uF 10%	16V
C116	1-163-037-11	CERAMIC CHIP 0.022uF 10%	25V
C117	1-163-809-11	CERAMIC CHIP 0.047uF 10%	25V
C118	1-163-038-11	CERAMIC CHIP 0.1uF	25V
C119	1-125-822-11	TANTALUM 10uF 20%	10V
C121	1-125-822-11	TANTALUM 10uF 20%	10V
C122	1-163-021-11	CERAMIC CHIP 0.01uF 10%	50V
C123	1-163-038-11	CERAMIC CHIP 0.1uF	25V
C124	1-163-038-11	CERAMIC CHIP 0.1uF	25V
C127	1-163-038-11	CERAMIC CHIP 0.1uF	25V
C128	1-163-021-11	CERAMIC CHIP 0.01uF 10%	50V
C129	1-107-823-11	CERAMIC CHIP 0.47uF 10%	16V
C130	1-163-251-11	CERAMIC CHIP 100PF 5%	50V
C131	1-163-023-00	CERAMIC CHIP 0.015uF 5%	50V
C132	1-107-823-11	CERAMIC CHIP 0.47uF 10%	16V
C133	1-163-017-00	CERAMIC CHIP 0.0047uF 5%	50V
C134	1-163-038-11	CERAMIC CHIP 0.1uF	25V

Ref. No.	Part No.	Description	Remark
C135	1-163-038-11	CERAMIC CHIP 0.1uF	25V
C136	1-126-206-11	ELECT CHIP 100uF 20%	6.3V
C142	1-163-251-11	CERAMIC CHIP 100PF 5%	50V
C143	1-163-251-11	CERAMIC CHIP 100PF 5%	50V
C144	1-163-251-11	CERAMIC CHIP 100PF 5%	50V
C146	1-163-038-11	CERAMIC CHIP 0.1uF	25V
C151	1-126-206-11	ELECT CHIP 100uF 20%	6.3V
C152	1-163-038-11	CERAMIC CHIP 0.1uF	25V
C153	1-163-021-11	CERAMIC CHIP 0.01uF 10%	50V
C156	1-163-038-11	CERAMIC CHIP 0.1uF	25V
C158	1-163-019-00	CERAMIC CHIP 0.0068uF 10%	50V
C160	1-104-601-11	ELECT CHIP 10uF 20%	10V
C161	1-104-601-11	ELECT CHIP 10uF 20%	10V
C163	1-163-021-11	CERAMIC CHIP 0.01uF 10%	50V
C164	1-163-021-11	CERAMIC CHIP 0.01uF 10%	50V
C167	1-163-038-11	CERAMIC CHIP 0.1uF	25V
C168	1-163-038-11	CERAMIC CHIP 0.1uF	25V
C169	1-125-822-11	TANTALUM 10uF 20%	10V
C171	1-163-038-11	CERAMIC CHIP 0.1uF	25V
C181	1-104-913-11	TANTALUM CHIP 10uF 20%	16V
C183	1-163-038-11	CERAMIC CHIP 0.1uF	25V
C184	1-117-970-11	ELECT CHIP 22uF 20%	10V
C185	1-164-611-11	CERAMIC CHIP 0.001uF 10%	500V
C187	1-104-913-11	TANTALUM CHIP 10uF 20%	16V
C188	1-163-021-11	CERAMIC CHIP 0.01uF 10%	50V
C189	1-163-989-11	CERAMIC CHIP 0.033uF 10%	25V
C190	1-126-206-11	ELECT CHIP 100uF 20%	6.3V
C191	1-163-038-11	CERAMIC CHIP 0.1uF	25V
C196	1-163-038-11	CERAMIC CHIP 0.1uF	25V
C197	1-163-038-11	CERAMIC CHIP 0.1uF	25V
< CONNECTOR >			
CN101	1-569-479-51	CONNECTOR, FPC 21P	
CN102	1-784-833-21	CONNECTOR, FFC (LIF (NON-ZIF)) 21P	
CN103	1-784-834-21	CONNECTOR, FFC (LIF (NON-ZIF)) 23P	
CN104	1-770-687-11	CONNECTOR, FFC/FPC 4P	
CN110	1-695-440-21	PIN, CONNECTOR (PC BOARD) 6P	
< DIODE >			
D101	8-719-988-61	DIODE 1SS355TE-17	
D181	8-719-046-86	DIODE F1J6TP	
D183	8-719-046-86	DIODE F1J6TP	
< IC/TRANSISTOR >			
IC101	8-752-080-95	IC CXA2523AR	
IC103	8-729-903-10	TRANSISTOR FMW1-T-148	
IC121	8-752-389-44	IC CXD2654R	
IC123	8-759-096-87	IC TC7WU04FU (TE12R)	
IC124	8-759-334-38	IC MSM51V4400-70TS-K	
IC152	8-759-430-25	IC BH6511FS	
IC171	8-759-640-39	IC BR24C02F-WE2	
IC181	8-759-481-17	IC MC74ACT08DTR2	
IC192	8-759-460-72	IC BA033FP-E2	
< COIL/SHORT >			
L101	1-414-813-11	FERRITE 0uH	
L102	1-414-813-11	FERRITE 0uH	
L103	1-414-813-11	FERRITE 0uH	

Ref. No.	Part No.	Description	Remark
L105	1-414-813-11	FERRITE	0uH
L106	1-414-813-11	FERRITE	0uH
L121	1-414-813-11	FERRITE	0uH
L122	1-414-813-11	FERRITE	0uH
L151	1-412-029-11	INDUCTOR CHIP	10uH
L152	1-412-029-11	INDUCTOR CHIP	10uH
L153	1-412-032-11	INDUCTOR CHIP	100uH
L154	1-412-032-11	INDUCTOR CHIP	100uH
L161	1-414-813-11	FERRITE	0uH
L162	1-414-813-11	FERRITE	0uH
L181	1-216-295-11	SHORT	0
< TRANSISTOR >			
Q101	8-729-028-91	TRANSISTOR	RT1P441M-TP-1
Q102	8-729-026-53	TRANSISTOR	2SA1576A-T106-QR
Q103	8-729-028-99	TRANSISTOR	RT1N144M-TP-1
Q104	8-729-028-99	TRANSISTOR	RT1N144M-TP-1
Q162	8-729-101-07	TRANSISTOR	2SB798-T1DK
Q163	8-729-028-91	TRANSISTOR	RT1P441M-TP-1
Q181	8-729-018-75	FET	2SJ278MYTR
Q182	8-729-017-65	FET	2SK1764KYTR
< RESISTOR >			
R103	1-216-049-11	RES-CHIP	1K 5% 1/10W
R104	1-216-073-00	METAL CHIP	10K 5% 1/10W
R105	1-216-065-00	RES-CHIP	4.7K 5% 1/10W
R106	1-216-133-00	METAL CHIP	3.3M 5% 1/10W
R107	1-216-113-00	METAL CHIP	470K 5% 1/10W
R109	1-216-295-11	SHORT	0
R110	1-216-073-00	METAL CHIP	10K 5% 1/10W
R111	1-216-295-11	SHORT	0
R112	1-216-089-11	RES-CHIP	47K 5% 1/10W
R113	1-216-049-11	RES-CHIP	1K 5% 1/10W
R115	1-216-049-11	RES-CHIP	1K 5% 1/10W
R117	1-216-113-00	METAL CHIP	470K 5% 1/10W
R120	1-216-025-11	RES-CHIP	100 5% 1/10W
R121	1-216-097-11	RES-CHIP	100K 5% 1/10W
R123	1-216-295-11	SHORT	0
R124	1-216-025-11	RES-CHIP	100 5% 1/10W
R125	1-216-025-11	RES-CHIP	100 5% 1/10W
R127	1-216-025-11	RES-CHIP	100 5% 1/10W
R129	1-216-295-11	SHORT	0
R130	1-216-295-11	SHORT	0
R131	1-216-073-00	METAL CHIP	10K 5% 1/10W
R132	1-216-097-11	RES-CHIP	100K 5% 1/10W
R133	1-216-117-00	METAL CHIP	680K 5% 1/10W
R134	1-216-049-11	RES-CHIP	1K 5% 1/10W
R135	1-216-061-00	METAL CHIP	3.3K 5% 1/10W
R136	1-216-049-11	RES-CHIP	1K 5% 1/10W
R137	1-216-295-11	SHORT	0
R140	1-216-029-00	METAL CHIP	150 5% 1/10W
R142	1-216-073-00	METAL CHIP	10K 5% 1/10W
R143	1-216-073-00	METAL CHIP	10K 5% 1/10W
R144	1-216-025-11	RES-CHIP	100 5% 1/10W
R145	1-216-073-00	METAL CHIP	10K 5% 1/10W
R146	1-216-037-00	METAL CHIP	330 5% 1/10W
R147	1-216-025-11	RES-CHIP	100 5% 1/10W
R148	1-216-045-00	METAL CHIP	680 5% 1/10W

Ref. No.	Part No.	Description	Remark
R149	1-216-073-00	METAL CHIP	10K 5% 1/10W
R150	1-216-295-11	SHORT	0
R151	1-216-073-00	METAL CHIP	10K 5% 1/10W
R152	1-216-073-00	METAL CHIP	10K 5% 1/10W
R158	1-216-097-11	RES-CHIP	100K 5% 1/10W
R159	1-216-097-11	RES-CHIP	100K 5% 1/10W
R160	1-216-295-11	SHORT	0
R161	1-216-057-00	METAL CHIP	2.2K 5% 1/10W
R162	1-216-057-00	METAL CHIP	2.2K 5% 1/10W
R163	1-216-057-00	METAL CHIP	2.2K 5% 1/10W
R164	1-216-045-00	METAL CHIP	680 5% 1/10W
R165	1-216-097-11	RES-CHIP	100K 5% 1/10W
R166	1-216-298-00	METAL CHIP	2.2 5% 1/10W
R167	1-216-065-00	RES-CHIP	4.7K 5% 1/10W
R169	1-219-724-11	METAL CHIP	1 1% 1/4W
R170	1-216-073-00	METAL CHIP	10K 5% 1/10W
R171	1-216-073-00	METAL CHIP	10K 5% 1/10W
R173	1-216-121-11	RES-CHIP	1M 5% 1/10W
R175	1-216-065-00	RES-CHIP	4.7K 5% 1/10W
R177	1-216-061-00	METAL CHIP	3.3K 5% 1/10W
R179	1-216-085-00	METAL CHIP	33K 5% 1/10W
R180	1-216-073-00	METAL CHIP	10K 5% 1/10W
R182	1-216-089-11	RES-CHIP	47K 5% 1/10W
R183	1-216-089-11	RES-CHIP	47K 5% 1/10W
R184	1-216-073-00	METAL CHIP	10K 5% 1/10W
R185	1-216-081-00	METAL CHIP	22K 5% 1/10W
R186	1-216-089-11	RES-CHIP	47K 5% 1/10W
R188	1-216-073-00	METAL CHIP	10K 5% 1/10W
R189	1-216-073-00	METAL CHIP	10K 5% 1/10W
R190	1-216-073-00	METAL CHIP	10K 5% 1/10W
R195	1-216-073-00	METAL CHIP	10K 5% 1/10W
R196	1-216-295-11	SHORT	0
R197	1-216-295-11	SHORT	0
R198	1-216-296-00	SHORT	0
< SWITCH >			
S101	1-762-596-21	SWITCH, PUSH (1 KEY) (LIMIT)	
S102	1-762-148-21	SWITCH, PUSH (2 KEY)	(PROTECT/REFLECT RATE DETECT)

	1-674-336-12	LOADING BOARD	*****
< CONNECTOR >			
* CN151	1-568-943-11	PIN, CONNECTOR 5P	
< SWITCH >			
S1	1-771-799-11	SWITCH, LEVER (SLIDE)	(CD TRAY OPEN/CLOSE DETECT)

MAIN

Ref. No.	Part No.	Description	Remark	Ref. No.	Part No.	Description	Remark
	A-4475-919-A	MAIN BOARD, COMPLETE (HK, TW)		C363	1-126-957-11	ELECT	0.22uF 20% 50V
	A-4475-923-A	MAIN BOARD, COMPLETE (KR)		C364	1-130-473-00	MYLAR	0.0015uF 5% 50V
		*****		C365	1-124-721-11	ELECT	10uF 20% 50V
				C366	1-136-165-00	FILM	0.1uF 5% 50V
	7-685-646-79	SCREW +BVTP 3X8 TYPE2 N-S		C367	1-136-165-00	FILM	0.1uF 5% 50V
		< CAPACITOR >		C501	1-164-025-51	CERAMIC	18PF 5% 50V
BT922	1-125-623-11	DOUBLE LAYER	0.22F 5.5V	C502	1-164-025-51	CERAMIC	18PF 5% 50V
C101	1-162-282-31	CERAMIC	100PF 10% 50V	C503	1-162-306-11	CERAMIC	0.01uF 30% 16V
C102	1-162-294-31	CERAMIC	0.001uF 10% 50V	C504	1-162-306-11	CERAMIC	0.01uF 30% 16V
C103	1-126-964-11	ELECT	10uF 20% 50V	C505	1-164-159-11	CERAMIC	0.1uF 50V
C141	1-126-933-11	ELECT	100uF 20% 16V	C506	1-162-306-11	CERAMIC	0.01uF 30% 16V
C142	1-126-933-11	ELECT	100uF 20% 16V	C507	1-126-933-11	ELECT	100uF 20% 16V
C143	1-126-933-11	ELECT	100uF 20% 16V	C508	1-162-282-31	CERAMIC	100PF 10% 50V
C144	1-126-964-11	ELECT	10uF 20% 50V	C521	1-164-159-11	CERAMIC	0.1uF 50V
C145	1-126-964-11	ELECT	10uF 20% 50V	C901	1-124-721-11	ELECT	10uF 20% 50V
C151	1-162-282-31	CERAMIC	100PF 10% 50V	C902	1-124-721-11	ELECT	10uF 20% 50V
C152	1-162-294-31	CERAMIC	0.001uF 10% 50V	C903	1-124-721-11	ELECT	10uF 20% 50V
C153	1-126-964-11	ELECT	10uF 20% 50V	C904	1-126-964-11	ELECT	10uF 20% 50V
C161	1-126-933-11	ELECT	100uF 20% 16V	C905	1-126-926-11	ELECT	1000uF 20% 10V
C166	1-162-290-31	CERAMIC	470PF 10% 50V	C906	1-124-721-11	ELECT	10uF 20% 50V
C167	1-162-294-31	CERAMIC	0.001uF 10% 50V	C911	1-126-052-11	ELECT	100uF 20% 50V
C168	1-162-282-31	CERAMIC	100PF 10% 50V	C912	1-124-721-11	ELECT	10uF 20% 50V
C169	1-162-282-31	CERAMIC	100PF 10% 50V	C913	1-126-964-11	ELECT	10uF 20% 50V
C171	1-164-159-11	CERAMIC	0.1uF 50V	C914	1-126-926-11	ELECT	1000uF 20% 10V
C172	1-162-306-11	CERAMIC	0.01uF 30% 16V	C915	1-126-964-11	ELECT	10uF 20% 50V
C173	1-126-933-11	ELECT	100uF 20% 16V	C916	1-126-926-11	ELECT	1000uF 20% 10V
C174	1-164-159-11	CERAMIC	0.1uF 50V	C917	1-126-933-11	ELECT	100uF 20% 16V
C175	1-164-159-11	CERAMIC	0.1uF 50V	C921	1-126-964-11	ELECT	10uF 20% 50V
C301	1-126-964-11	ELECT	10uF 20% 50V	C922	1-126-926-11	ELECT	1000uF 20% 10V
C302	1-162-302-11	CERAMIC	0.0022uF 30% 16V	C923	1-126-933-11	ELECT	100uF 20% 16V
C303	1-126-964-11	ELECT	10uF 20% 50V	C931	1-126-933-11	ELECT	100uF 20% 16V
C304	1-130-475-00	MYLAR	0.0022uF 5% 50V	C932	1-126-960-11	ELECT	1uF 20% 50V
C305	1-124-721-11	ELECT	10uF 20% 50V	C933	1-164-159-11	CERAMIC	0.1uF 50V
C306	1-162-302-11	CERAMIC	0.0022uF 30% 16V	C934	1-162-306-11	CERAMIC	0.01uF 30% 16V
C307	1-126-964-11	ELECT	10uF 20% 50V	C935	1-164-159-11	CERAMIC	0.1uF 50V
C310	1-162-294-31	CERAMIC	0.001uF 10% 50V	C941	1-126-947-11	ELECT	47uF 20% 35V
C311	1-124-721-11	ELECT	10uF 20% 50V	C942	1-164-159-11	CERAMIC	0.1uF 50V
C312	1-136-165-00	FILM	0.1uF 5% 50V	C943	1-164-159-11	CERAMIC	0.1uF 50V
C313	1-126-957-11	ELECT	0.22uF 20% 50V	C945	1-164-159-11	CERAMIC	0.1uF 50V
C314	1-130-473-00	MYLAR	0.0015uF 5% 50V			< CONNECTOR >	
C315	1-124-721-11	ELECT	10uF 20% 50V	* CN101	1-766-955-11	CONNECTOR, BOARD TO BOARD 11P	
C316	1-136-165-00	FILM	0.1uF 5% 50V	* CN102	1-566-856-11	SOCKET, CONNECTOR 5P (TAPE CONTROL)	
C317	1-136-165-00	FILM	0.1uF 5% 50V	CN103	1-770-731-11	CONNECTOR, BOARD TO BOARD 12P	
C323	1-124-721-11	ELECT	10uF 20% 50V	CN105	1-784-776-11	CONNECTOR, FFC 15P	
C324	1-124-724-11	ELECT	47uF 20% 50V	CN106	1-568-683-11	PIN, CONNECTOR (PC BAORD) 2P	
C325	1-130-477-00	MYLAR	0.0033uF 5% 50V	CN107	1-784-786-11	CONNECTOR, FFC 25P	
C326	1-162-286-31	CERAMIC	220PF 10% 50V	CN109	1-784-780-11	CONNECTOR, FFC 19P	
C351	1-126-964-11	ELECT	10uF 20% 50V	* CN110	1-568-954-11	PIN, CONNECTOR 5P	
C352	1-162-302-11	CERAMIC	0.0022uF 30% 16V	CN111	1-568-844-11	CONNECTOR, FFC 29P	
C353	1-126-964-11	ELECT	10uF 20% 50V			< DIODE >	
C354	1-130-475-00	MYLAR	0.0022uF 5% 50V	D171	8-719-947-13	DIODE MTZJ-T-72-4.7B	
C355	1-124-721-11	ELECT	10uF 20% 50V	D901	8-719-024-99	DIODE 11ES2-NTA2B	
C356	1-162-302-11	CERAMIC	0.0022uF 30% 16V	D911	8-719-024-99	DIODE 11ES2-NTA2B	
C357	1-126-964-11	ELECT	10uF 20% 50V	D912	8-719-911-19	DIODE 1SS119-25	
C360	1-162-294-31	CERAMIC	0.001uF 10% 50V	D913	8-719-911-19	DIODE 1SS119-25	
C361	1-124-721-11	ELECT	10uF 20% 50V	D914	8-719-911-19	DIODE 1SS119-25	
C362	1-136-165-00	FILM	0.1uF 5% 50V				

Ref. No.	Part No.	Description	Remark	Ref. No.	Part No.	Description	Remark
D921	8-719-024-99	DIODE 11ES2-NTA2B		R132	1-247-807-31	CARBON 100 5%	1/4W
D922	8-719-911-19	DIODE 1SS119-25		R141	1-249-417-11	CARBON 1K 5%	1/4W
D923	8-719-911-19	DIODE 1SS119-25		R151	1-249-441-11	CARBON 100K 5%	1/4W
D924	8-719-911-19	DIODE 1SS119-25		R152	1-249-417-11	CARBON 1K 5%	1/4W
D941	8-719-911-19	DIODE 1SS119-25		R153	1-249-429-11	CARBON 10K 5%	1/4W
D942	8-719-911-19	DIODE 1SS119-25		R154	1-249-417-11	CARBON 1K 5%	1/4W
D943	8-719-911-19	DIODE 1SS119-25		R155	1-249-441-11	CARBON 100K 5%	1/4W
D946	8-719-911-19	DIODE 1SS119-25		R156	1-249-441-11	CARBON 100K 5%	1/4W
< GROUND TERMINAL >				R171	1-249-409-11	CARBON 220 5%	1/4W
EP1	1-537-770-21	TERMINAL BOARD, GROUND		R172	1-249-414-11	CARBON 560 5%	1/4W
EP2	1-537-770-21	TERMINAL BOARD, GROUND		R302	1-247-843-11	CARBON 3.3K 5%	1/4W
< IC >				R303	1-249-441-11	CARBON 100K 5%	1/4W
IC171	8-759-822-09	IC LB1641		R304	1-249-417-11	CARBON 1K 5%	1/4W
IC301	8-759-494-40	IC M62428AFP600C		R306	1-249-417-11	CARBON 1K 5%	1/4W
IC501	8-759-675-41	IC M30620MCA-A51FP		R309	1-249-437-11	CARBON 47K 5%	1/4W
IC901	8-759-394-35	IC BA12T		R312	1-249-424-11	CARBON 3.9K 5%	1/4W
IC902	8-759-604-86	IC M5F7807L		R313	1-247-885-00	CARBON 180K 5%	1/4W
IC903	8-759-450-49	IC BA07T		R314	1-249-433-11	CARBON 22K 5%	1/4W
IC911	8-759-647-11	IC uPC2905HF		R315	1-247-903-00	CARBON 1M 5%	1/4W
IC912	8-759-445-59	IC BA033T		R316	1-249-441-11	CARBON 100K 5%	1/4W
IC913	8-759-647-11	IC uPC2905HF		R321	1-249-435-11	CARBON 33K 5%	1/4W
IC921	8-759-647-11	IC uPC2905HF		R322	1-247-903-00	CARBON 1M 5%	1/4W
IC931	8-759-481-02	IC M62016L		R323	1-249-417-11	CARBON 1K 5%	1/4W
IC941	8-759-637-58	IC PST592C-T		R324	1-249-417-11	CARBON 1K 5%	1/4W
< JACK >				R325	1-249-417-11	CARBON 1K 5%	1/4W
J101	1-779-653-12	JACK, PIN (TAPE IN/OUT)		R326	1-249-413-11	CARBON 470 5%	1/4W
< TRANSISTOR >				R352	1-247-843-11	CARBON 3.3K 5%	1/4W
Q101	8-729-620-05	TRANSISTOR 2SC2603-EF		R353	1-249-441-11	CARBON 100K 5%	1/4W
Q102	8-729-900-63	TRANSISTOR DTA124ES		R354	1-249-417-11	CARBON 1K 5%	1/4W
Q111	8-729-048-96	FET 2SK1825		R356	1-249-417-11	CARBON 1K 5%	1/4W
Q112	8-729-048-96	FET 2SK1825		R359	1-249-437-11	CARBON 47K 5%	1/4W
Q151	8-729-620-05	TRANSISTOR 2SC2603-EF		R362	1-249-424-11	CARBON 3.9K 5%	1/4W
Q301	8-729-620-05	TRANSISTOR 2SC2603-EF		R363	1-247-885-00	CARBON 180K 5%	1/4W
Q351	8-729-620-05	TRANSISTOR 2SC2603-EF		R364	1-249-433-11	CARBON 22K 5%	1/4W
Q501	8-729-422-73	TRANSISTOR UN4212		R365	1-247-903-00	CARBON 1M 5%	1/4W
Q551	8-729-422-73	TRANSISTOR UN4212		R366	1-249-441-11	CARBON 100K 5%	1/4W
Q552	8-729-900-63	TRANSISTOR DTA124ES		R391	1-247-830-11	CARBON 910 5%	1/4W
Q911	8-729-118-01	TRANSISTOR 2SB1116-K		R501	1-247-807-31	CARBON 100 5%	1/4W
Q912	8-729-422-73	TRANSISTOR UN4212		R502	1-249-417-11	CARBON 1K 5%	1/4W
Q921	8-729-620-05	TRANSISTOR 2SC2603-EF		R505	1-249-437-11	CARBON 47K 5%	1/4W
Q931	8-729-620-05	TRANSISTOR 2SC2603-EF		R506	1-249-417-11	CARBON 1K 5%	1/4W
Q941	8-729-620-05	TRANSISTOR 2SC2603-EF		R507	1-247-807-31	CARBON 100 5%	1/4W
< RESISTOR >				R508	1-247-807-31	CARBON 100 5%	1/4W
R101	1-249-441-11	CARBON 100K 5%	1/4W	R509	1-247-807-31	CARBON 100 5%	1/4W
R102	1-249-417-11	CARBON 1K 5%	1/4W	R510	1-249-417-11	CARBON 1K 5%	1/4W
R103	1-249-429-11	CARBON 10K 5%	1/4W	R511	1-247-807-31	CARBON 100 5%	1/4W
R104	1-249-417-11	CARBON 1K 5%	1/4W	R512	1-247-807-31	CARBON 100 5%	1/4W
R105	1-249-441-11	CARBON 100K 5%	1/4W	R513	1-247-807-31	CARBON 100 5%	1/4W
R106	1-249-441-11	CARBON 100K 5%	1/4W	R514	1-247-807-31	CARBON 100 5%	1/4W
R111	1-249-393-11	CARBON 10 5%	1/4W	R515	1-247-807-31	CARBON 100 5%	1/4W
R112	1-249-393-11	CARBON 10 5%	1/4W	R516	1-247-807-31	CARBON 100 5%	1/4W
R113	1-249-437-11	CARBON 47K 5%	1/4W	R517	1-247-807-31	CARBON 100 5%	1/4W
R114	1-249-441-11	CARBON 100K 5%	1/4W	R518	1-247-807-31	CARBON 100 5%	1/4W
				R519	1-249-417-11	CARBON 1K 5%	1/4W
				R520	1-249-417-11	CARBON 1K 5%	1/4W
				R521	1-247-807-31	CARBON 100 5%	1/4W
				R522	1-247-807-31	CARBON 100 5%	1/4W

MAIN

MD DIGITAL

Ref. No.	Part No.	Description	Remark
R523	1-249-417-11	CARBON	1K 5% 1/4W
R524	1-247-807-31	CARBON	100 5% 1/4W
R525	1-249-417-11	CARBON	1K 5% 1/4W
R526	1-247-807-31	CARBON	100 5% 1/4W
R527	1-247-807-31	CARBON	100 5% 1/4W
R528	1-247-807-31	CARBON	100 5% 1/4W
R529	1-247-807-31	CARBON	100 5% 1/4W
R530	1-247-807-31	CARBON	100 5% 1/4W
R531	1-249-417-11	CARBON	1K 5% 1/4W
R532	1-249-417-11	CARBON	1K 5% 1/4W
R533	1-249-417-11	CARBON	1K 5% 1/4W
R534	1-249-417-11	CARBON	1K 5% 1/4W
R535	1-249-417-11	CARBON	1K 5% 1/4W
R536	1-249-417-11	CARBON	1K 5% 1/4W
R537	1-249-417-11	CARBON	1K 5% 1/4W
R538	1-249-417-11	CARBON	1K 5% 1/4W
R539	1-249-417-11	CARBON	1K 5% 1/4W
R540	1-249-417-11	CARBON	1K 5% 1/4W
R541	1-249-417-11	CARBON	1K 5% 1/4W
R542	1-249-417-11	CARBON	1K 5% 1/4W
R543	1-249-417-11	CARBON	1K 5% 1/4W
R544	1-249-417-11	CARBON	1K 5% 1/4W
R545	1-249-417-11	CARBON	1K 5% 1/4W
R547	1-247-807-31	CARBON	100 5% 1/4W
R548	1-247-807-31	CARBON	100 5% 1/4W
R549	1-247-807-31	CARBON	100 5% 1/4W
R550	1-247-807-31	CARBON	100 5% 1/4W
R551	1-249-437-11	CARBON	47K 5% 1/4W
R552	1-249-429-11	CARBON	10K 5% 1/4W
R553	1-249-417-11	CARBON	1K 5% 1/4W
R554	1-249-417-11	CARBON	1K 5% 1/4W
R555	1-249-429-11	CARBON	10K 5% 1/4W
R556	1-249-429-11	CARBON	10K 5% 1/4W
R557	1-249-429-11	CARBON	10K 5% 1/4W
R558	1-249-429-11	CARBON	10K 5% 1/4W
R559	1-249-429-11	CARBON	10K 5% 1/4W
R560	1-249-427-11	CARBON	6.8K 5% 1/4W
R561	1-249-427-11	CARBON	6.8K 5% 1/4W
R562	1-249-427-11	CARBON	6.8K 5% 1/4W
R563	1-249-417-11	CARBON	1K 5% 1/4W
R564	1-249-417-11	CARBON	1K 5% 1/4W
R565	1-249-412-11	CARBON	390 5% 1/4W
R566	1-249-426-11	CARBON	5.6K 5% 1/4W
R567	1-247-843-11	CARBON	3.3K 5% 1/4W
R568	1-249-429-11	CARBON	10K 5% 1/4W
R569	1-249-429-11	CARBON	10K 5% 1/4W
R570	1-249-429-11	CARBON	10K 5% 1/4W
R573	1-247-807-31	CARBON	100 5% 1/4W
R591	1-249-425-11	CARBON	4.7K 5% 1/4W
R592	1-249-425-11	CARBON	4.7K 5% 1/4W
R911	1-249-409-11	CARBON	220 5% 1/4W
R921	1-247-807-31	CARBON	100 5% 1/4W
R922	1-249-429-11	CARBON	10K 5% 1/4W
R923	1-249-433-11	CARBON	22K 5% 1/4W
R925	1-249-411-11	CARBON	330 5% 1/4W
R926	1-249-385-11	CARBON	2.2 5% 1/6W
R931	1-247-887-00	CARBON	220K 5% 1/4W
R932	1-249-441-11	CARBON	100K 5% 1/4W

Ref. No.	Part No.	Description	Remark
R933	1-249-433-11	CARBON	22K 5% 1/4W
R941	1-249-413-11	CARBON	470 5% 1/4W
R942	1-249-429-11	CARBON	10K 5% 1/4W
R943	1-249-437-11	CARBON	47K 5% 1/4W
R946	1-249-433-11	CARBON	22K 5% 1/4W
R947	1-249-437-11	CARBON	47K 5% 1/4W
R949	1-249-429-11	CARBON	10K 5% 1/4W
< VIBRATOR >			
X501	1-781-107-21	VIBRATOR, SERAMIC (16MHz)	
X502	1-567-098-41	VIBRATOR, CRYSTAL (32.768kHz)	

A-4475-917-A		MD DIGITAL BOARD, COMPLETE	

< CAPACITOR >			
C171	1-163-038-11	CERAMIC CHIP	0.1uF 25V
C172	1-126-206-11	ELECT CHIP	100uF 20% 6.3V
C201	1-163-234-11	CERAMIC CHIP	20PF 5% 50V
C202	1-163-229-11	CERAMIC CHIP	12PF 5% 50V
C203	1-163-021-11	CERAMIC CHIP	0.01uF 10% 50V
C216	1-126-205-11	ELECT CHIP	47uF 20% 6.3V
C341	1-126-205-11	ELECT CHIP	47uF 20% 6.3V
C342	1-126-206-11	ELECT CHIP	100uF 20% 6.3V
C343	1-126-205-11	ELECT CHIP	47uF 20% 6.3V
C350	1-163-038-11	CERAMIC CHIP	0.1uF 25V
C351	1-163-038-11	CERAMIC CHIP	0.1uF 25V
C352	1-126-205-11	ELECT CHIP	47uF 20% 6.3V
C353	1-163-038-11	CERAMIC CHIP	0.1uF 25V
C355	1-163-251-11	CERAMIC CHIP	100PF 5% 50V
C357	1-163-021-11	CERAMIC CHIP	0.01uF 10% 50V
C358	1-163-251-11	CERAMIC CHIP	100PF 5% 50V
C359	1-163-251-11	CERAMIC CHIP	100PF 5% 50V
C360	1-163-251-11	CERAMIC CHIP	100PF 5% 50V
C362	1-163-038-11	CERAMIC CHIP	0.1uF 25V
C363	1-163-251-11	CERAMIC CHIP	100PF 5% 50V
C503	1-126-206-11	ELECT CHIP	100uF 20% 6.3V
C509	1-126-206-11	ELECT CHIP	100uF 20% 6.3V
C510	1-126-206-11	ELECT CHIP	100uF 20% 6.3V
C522	1-163-038-11	CERAMIC CHIP	0.1uF 25V
C527	1-163-038-11	CERAMIC CHIP	0.1uF 25V
C528	1-163-038-11	CERAMIC CHIP	0.1uF 25V
C529	1-163-038-11	CERAMIC CHIP	0.1uF 25V
C2001	1-163-125-00	CERAMIC CHIP	220PF 5% 50V
< CONNECTOR >			
CN101	1-793-311-11	CONNECTOR, FFC (LIF (NON-ZIF)) 25P	
CN102	1-784-687-41	PIN, CONNECTOR (PC BOARD) 7P	
CN103	1-784-834-21	CONNECTOR, FFC (LIF (NON-ZIF)) 23P	
CN104	1-784-833-21	CONNECTOR, FFC (LIF (NON-ZIF)) 21P	
< IC >			
IC153	8-759-481-19	IC LB1830M-S-TE-L	
IC201	8-759-553-65	IC UDA1341TS	
IC202	8-759-564-53	IC MC74HC04ADTR2	
IC316	8-759-657-09	IC M30624MG-A16FP	

Ref. No.	Part No.	Description	Remark
< COIL >			
L181	1-424-675-11	INDUCTOR 33uH	
L201	1-500-445-21	FERRITE 0uH	
L202	1-500-445-21	FERRITE 0uH	
< TRANSISTOR >			
Q350	8-729-028-99	TRANSISTOR RT1N144M-TP-1	
< RESISTOR >			
R201	1-216-121-11	RES-CHIP 1M 5% 1/10W	
R202	1-216-041-00	METAL CHIP 470 5% 1/10W	
R203	1-216-049-11	RES-CHIP 1K 5% 1/10W	
R204	1-216-089-11	RES-CHIP 47K 5% 1/10W	
R205	1-216-113-00	METAL CHIP 470K 5% 1/10W	
R207	1-216-025-11	RES-CHIP 100 5% 1/10W	
R210	1-216-041-00	METAL CHIP 470 5% 1/10W	
R330	1-216-073-00	METAL CHIP 10K 5% 1/10W	
R331	1-216-097-11	RES-CHIP 100K 5% 1/10W	
R333	1-216-073-00	METAL CHIP 10K 5% 1/10W	
R349	1-216-073-00	METAL CHIP 10K 5% 1/10W	
R351	1-216-057-00	METAL CHIP 2.2K 5% 1/10W	
R352	1-216-053-00	METAL CHIP 1.5K 5% 1/10W	
R353	1-216-053-00	METAL CHIP 1.5K 5% 1/10W	
R358	1-216-073-00	METAL CHIP 10K 5% 1/10W	
R361	1-216-073-00	METAL CHIP 10K 5% 1/10W	
R363	1-216-073-00	METAL CHIP 10K 5% 1/10W	
R366	1-216-097-11	RES-CHIP 100K 5% 1/10W	
R367	1-216-097-11	RES-CHIP 100K 5% 1/10W	
R370	1-216-073-00	METAL CHIP 10K 5% 1/10W	
R383	1-216-073-00	METAL CHIP 10K 5% 1/10W	
R384	1-216-073-00	METAL CHIP 10K 5% 1/10W	
R385	1-216-073-00	METAL CHIP 10K 5% 1/10W	
R386	1-216-073-00	METAL CHIP 10K 5% 1/10W	
R391	1-216-073-00	METAL CHIP 10K 5% 1/10W	
R395	1-216-073-00	METAL CHIP 10K 5% 1/10W	
R400	1-216-073-00	METAL CHIP 10K 5% 1/10W	
R816	1-216-174-00	RES-CHIP 100 5% 1/8W	
R817	1-216-174-00	RES-CHIP 100 5% 1/8W	
R818	1-216-174-00	RES-CHIP 100 5% 1/8W	
R819	1-216-174-00	RES-CHIP 100 5% 1/8W	
R2002	1-216-073-00	METAL CHIP 10K 5% 1/10W	
R2004	1-216-041-00	METAL CHIP 470 5% 1/10W	
R2005	1-216-025-11	RES-CHIP 100 5% 1/10W	
R2006	1-216-025-11	RES-CHIP 100 5% 1/10W	
R2007	1-216-025-11	RES-CHIP 100 5% 1/10W	
R2008	1-216-073-00	METAL CHIP 10K 5% 1/10W	
R2009	1-216-073-00	METAL CHIP 10K 5% 1/10W	
< VIBRATOR >			
X201	1-767-286-11	VIBRATOR, CRYSTAL (22MHz)	
X302	1-781-155-21	VIBRATOR, CERAMIC (10MHz)	

A-4475-916-A PANEL BOARD, COMPLETE

4-212-590-22 HOLDER (FL)

Ref. No.	Part No.	Description	Remark
< CAPACITOR >			
C601	1-162-306-11	CERAMIC 0.01uF 30% 16V	
C602	1-162-306-11	CERAMIC 0.01uF 30% 16V	
C603	1-124-261-00	ELECT 10uF 20% 50V	
C604	1-162-306-11	CERAMIC 0.01uF 30% 16V	
C605	1-162-306-11	CERAMIC 0.01uF 30% 16V	
C606	1-162-306-11	CERAMIC 0.01uF 30% 16V	
C623	1-162-306-11	CERAMIC 0.01uF 30% 16V	
C635	1-126-964-11	ELECT 10uF 20% 50V	
C636	1-128-551-11	ELECT 22uF 20% 25V	
C640	1-162-282-31	CERAMIC 100PF 10% 50V	
C648	1-162-286-21	CERAMIC 220PF 10% 50V	
C649	1-162-286-21	CERAMIC 220PF 10% 50V	
C650	1-162-286-21	CERAMIC 220PF 10% 50V	
C651	1-162-286-21	CERAMIC 220PF 10% 50V	
C652	1-162-286-21	CERAMIC 220PF 10% 50V	
C653	1-162-286-21	CERAMIC 220PF 10% 50V	
C654	1-162-286-21	CERAMIC 220PF 10% 50V	
C655	1-162-286-21	CERAMIC 220PF 10% 50V	
C656	1-162-286-21	CERAMIC 220PF 10% 50V	
C657	1-162-286-21	CERAMIC 220PF 10% 50V	
C658	1-162-286-21	CERAMIC 220PF 10% 50V	
C659	1-162-286-21	CERAMIC 220PF 10% 50V	
C660	1-162-286-21	CERAMIC 220PF 10% 50V	
C661	1-162-286-21	CERAMIC 220PF 10% 50V	
C662	1-162-286-21	CERAMIC 220PF 10% 50V	
C664	1-124-261-00	ELECT 10uF 20% 50V	
C665	1-104-664-11	ELECT 47uF 20% 16V	
C671	1-162-294-31	CERAMIC 0.001uF 10% 50V	
C672	1-162-294-31	CERAMIC 0.001uF 10% 50V	
C673	1-164-159-21	CERAMIC 0.1uF 50V	
C674	1-162-294-31	CERAMIC 0.001uF 10% 50V	
< CONNECTOR >			
CN601	1-779-757-11	SOCKET, CONNECTOR (L TYPE) 29P	
< LED >			
D661	8-719-056-13	LED SML79423C-TP15 (MD PLAY/PAUSE)	
D663	8-719-812-44	LED TLO124 (● REC)	
D664	8-719-032-86	LED SEL5420E (MD)	
D665	8-719-056-13	LED SML79423C-TP15 (CD PLAY/PAUSE)	
D667	8-719-032-86	LED SEL5420E (CD)	
D668	8-719-812-44	LED TLO124 (I/⏻)	
< FLUORESCENT INDICATOR TUBE >			
FL601	1-517-985-11	INDICATOR TUBE, FLUORESCENT	
< IC >			
IC601	8-759-297-23	IC M66004M8FP	
IC602	8-759-459-85	IC NJL63H400A	
< JACK >			
J601	1-764-106-21	JACK (PHONES)	

PANEL

POWER

Ref. No.	Part No.	Description	Remark
< TRANSISTOR >			
Q601	8-729-620-05	TRANSISTOR 2SC2603-EF	
Q661	8-729-900-63	TRANSISTOR DTA124ES	
Q662	8-729-900-63	TRANSISTOR DTA124ES	
Q663	8-729-900-80	TRANSISTOR DTC114ES	
Q664	8-729-900-80	TRANSISTOR DTC114ES	
Q665	8-729-900-63	TRANSISTOR DTA124ES	
Q666	8-729-900-63	TRANSISTOR DTA124ES	
Q667	8-729-900-80	TRANSISTOR DTC114ES	
< RESISTOR >			
R601	1-249-441-11	CARBON 100K 5%	1/4W
R603	1-249-417-11	CARBON 1K 5%	1/4W
R607	1-249-441-11	CARBON 100K 5%	1/4W
R608	1-249-434-11	CARBON 27K 5%	1/4W
R609	1-249-417-11	CARBON 1K 5%	1/4W
R610	1-249-417-11	CARBON 1K 5%	1/4W
R611	1-249-417-11	CARBON 1K 5%	1/4W
R612	1-249-417-11	CARBON 1K 5%	1/4W
R615	1-247-807-31	CARBON 100 5%	1/4W
R616	1-247-807-31	CARBON 100 5%	1/4W
R617	1-247-807-31	CARBON 100 5%	1/4W
R618	1-247-807-31	CARBON 100 5%	1/4W
R619	1-247-807-31	CARBON 100 5%	1/4W
R620	1-247-807-31	CARBON 100 5%	1/4W
R621	1-247-807-31	CARBON 100 5%	1/4W
R639	1-249-393-11	CARBON 10 5%	1/4W
R641	1-249-415-11	CARBON 680 5%	1/4W
R642	1-249-417-11	CARBON 1K 5%	1/4W
R643	1-249-419-11	CARBON 1.5K 5%	1/4W
R644	1-247-843-11	CARBON 3.3K 5%	1/4W
R645	1-249-425-11	CARBON 4.7K 5%	1/4W
R646	1-249-415-11	CARBON 680 5%	1/4W
R647	1-249-417-11	CARBON 1K 5%	1/4W
R648	1-249-419-11	CARBON 1.5K 5%	1/4W
R649	1-247-843-11	CARBON 3.3K 5%	1/4W
R650	1-249-425-11	CARBON 4.7K 5%	1/4W
R651	1-249-429-11	CARBON 10K 5%	1/4W
R652	1-249-435-11	CARBON 33K 5%	1/4W
R661	1-249-409-11	CARBON 220 5%	1/4W
R662	1-249-407-11	CARBON 150 5%	1/4W
R663	1-249-415-11	CARBON 680 5%	1/4W
R664	1-249-410-11	CARBON 270 5%	1/4W
R665	1-249-409-11	CARBON 220 5%	1/4W
R666	1-249-407-11	CARBON 150 5%	1/4W
R667	1-249-410-11	CARBON 270 5%	1/4W
R668	1-249-413-11	CARBON 470 5%	1/4W
< SWITCH >			
S601	1-418-632-11	ENCODER, ROTARY (VOLUME)	
S602	1-762-875-21	SWITCH, KEYBOARD (I/⌂)	
S603	1-762-875-21	SWITCH, KEYBOARD (□ (CD))	
S604	1-762-875-21	SWITCH, KEYBOARD (▷▶▶ (CD))	
S605	1-762-875-21	SWITCH, KEYBOARD (≡ (CD))	
S606	1-762-875-21	SWITCH, KEYBOARD (□ (MD))	
S607	1-762-875-21	SWITCH, KEYBOARD (▷▶▶ (MD))	
S608	1-762-875-21	SWITCH, KEYBOARD (≡ (MD))	

Ref. No.	Part No.	Description	Remark
S609	1-762-875-21	SWITCH, KEYBOARD (FUNCTION)	
S610	1-762-875-21	SWITCH, KEYBOARD (TUNING +, MD/CD ▶▶ ▶▶)	
S611	1-762-875-21	SWITCH, KEYBOARD (TUNER/BAND)	
S612	1-762-875-21	SWITCH, KEYBOARD (TUNING -, MD/CD ◀◀ ◀◀)	
S613	1-762-875-21	SWITCH, KEYBOARD (● REC)	
S614	1-762-875-21	SWITCH, KEYBOARD (CD-MD SYNC)	
S615	1-762-875-21	SWITCH, KEYBOARD (STEREO/MONO, REPEAT)	
S616	1-762-875-21	SWITCH, KEYBOARD (TUNING MODE, PLAY MODE)	

A-4475-920-A	POWER BOARD, COMPLETE (HK, TW)		
A-4475-924-A	POWER BOARD, COMPLETE (KR)		

11-533-293-11	FUSE HOLDER (HK, TW)		
< CAPACITOR >			
C971	1-136-165-00	FILM 0.1uF 5%	50V
C972	1-126-936-11	ELECT 3300uF 20%	16V
C973	1-136-165-00	FILM 0.1uF 5%	50V
C974	1-128-576-11	ELECT 100uF 20%	63V
C975	1-126-964-11	ELECT 10uF 20%	50V
C976	1-126-964-11	ELECT 10uF 20%	50V
C981	1-136-165-00	FILM 0.1uF 5%	50V
C982	1-135-933-11	ELECT 22000uF 20%	16V
C983	1-136-165-00	FILM 0.1uF 5%	50V
C984	1-126-943-11	ELECT 2200uF 20%	25V
△C991	1-113-925-11	CERAMIC 0.01uF 20%	250V
C992	1-126-961-11	ELECT 2.2uF 20%	50V
< CONNECTOR >			
CN991	1-564-321-00	PIN, CONNECTOR 2P	
* CN992	1-564-687-11	PIN, CONNECTOR 3P	
* CN993	1-564-519-11	PLUG, CONNECTOR 4P	
* CN994	1-770-730-11	CONNECTOR, BOARD TO BOARD 11P	
< DIODE >			
D971	8-719-024-99	DIODE 11ES2-NTA2B	
D972	8-719-024-99	DIODE 11ES2-NTA2B	
D973	8-719-024-99	DIODE 11ES2-NTA2B	
D974	8-719-024-99	DIODE 11ES2-NTA2B	
D975	8-719-024-99	DIODE 11ES2-NTA2B	
D976	8-719-024-99	DIODE 11ES2-NTA2B	
D977	8-719-024-99	DIODE 11ES2-NTA2B	
D978	8-719-024-99	DIODE 11ES2-NTA2B	
D979	8-719-983-86	DIODE MTZJ-T-72-33A	
D980	8-719-947-12	DIODE MTZJ-T-72-4.7A	
D981	8-719-028-23	DIODE D3SBA20-4101	
D982	8-719-024-99	DIODE 11ES2-NTA2B	
D983	8-719-024-99	DIODE 11ES2-NTA2B	
D984	8-719-024-99	DIODE 11ES2-NTA2B	
D985	8-719-024-99	DIODE 11ES2-NTA2B	
D986	8-719-911-19	DIODE 1SS119-25	
D987	8-719-911-19	DIODE 1SS119-25	
D991	8-719-911-19	DIODE 1SS119-25	

The components identified by mark △ or dotted line with mark △ are critical for safety. Replace only with part number specified.

Ref. No.	Part No.	Description	Remark
D992	8-719-911-19	DIODE 1SS119-25	
D993	8-719-911-19	DIODE 1SS119-25	
		< FUSE >	
△ F991	1-532-388-31	FUSE (T2AL/250V) (HK, TW)	
		< TRANSISTOR >	
Q971	8-729-018-59	TRANSISTOR 2SB1375 (LB-SONY)	
Q972	8-729-922-37	TRANSISTOR 2SD2144S-UVW	
Q973	8-729-922-37	TRANSISTOR 2SD2144S-UVW	
Q974	8-729-900-63	TRANSISTOR DTA124ES	
Q975	8-729-620-05	TRANSISTOR 2SC2603-EF	
Q991	8-729-620-05	TRANSISTOR 2SC2603-EF	
		< RESISTOR >	
△ R971	1-219-153-11	FUSIBLE 10 5% 1/4W F	
R972	1-249-421-11	CARBON 2.2K 5% 1/4W	
R973	1-249-425-11	CARBON 4.7K 5% 1/4W	
R974	1-249-413-11	CARBON 470 5% 1/4W	
R975	1-249-413-11	CARBON 470 5% 1/4W	
R976	1-249-429-11	CARBON 10K 5% 1/4W	
R977	1-249-429-11	CARBON 10K 5% 1/4W	
R978	1-249-441-11	CARBON 100K 5% 1/4W	
R979	1-249-417-11	CARBON 1K 5% 1/4W	
R980	1-249-417-11	CARBON 1K 5% 1/4W	
△ R981	1-219-121-11	FUSIBLE 0.22 5% 1/4W F	
△ R982	1-219-124-11	FUSIBLE 0.68 5% 1/4W F	
R991	1-249-429-11	CARBON 10K 5% 1/4W	
R992	1-249-429-11	CARBON 10K 5% 1/4W	
R993	1-249-417-11	CARBON 1K 5% 1/4W	
R994	1-249-417-11	CARBON 1K 5% 1/4W	
R995	1-247-843-11	CARBON 3.3K 5% 1/4W	
		< RELAY >	
△ RY991	1-755-276-11	RELAY, POWER	
		< SWITCH >	
△ S991	1-571-309-11	SWITCH (VOLTAGE SELECTOR) (HK, TW)	
		< TRANSFORMER >	
△ T900	1-433-970-11	TRANSFORMER, POWER	
△ T992	1-424-485-11	FILTER, LINE	

	1-674-628-12	SP BOARD	

		< CAPACITOR >	
C881	1-126-959-11	ELECT 0.47uF 20% 50V	
C882	1-136-495-11	FILM 0.068uF 5% 50V	
C883	1-136-495-11	FILM 0.068uF 5% 50V	
C884	1-136-495-11	FILM 0.068uF 5% 50V	
C885	1-136-495-11	FILM 0.068uF 5% 50V	
		< CONNECTOR >	
* CN881	1-770-747-11	CONNECTOR, BOARD TO BOARD 12P	
* CN882	1-770-747-11	CONNECTOR, BOARD TO BOARD 12P	

Ref. No.	Part No.	Description	Remark
		< DIODE >	
D881	8-719-911-19	DIODE 1SS119-25	
D882	8-719-911-19	DIODE 1SS119-25	
		< COIL >	
L881	1-420-872-00	COIL, AIR-CORE	
L882	1-420-872-00	COIL, AIR-CORE	
		< TRANSISTOR >	
Q881	8-729-111-29	TRANSISTOR 2SD1616A-K	
		< RESISTOR >	
△ R881	1-215-864-00	METAL OXIDE 150 5% 1W F	
△ R882	1-215-864-00	METAL OXIDE 150 5% 1W F	
△ R883	1-215-864-00	METAL OXIDE 150 5% 1W F	
△ R884	1-215-864-00	METAL OXIDE 150 5% 1W F	
R885	1-247-903-00	CARBON 1M 5% 1/4W	
R886	1-249-431-11	CARBON 15K 5% 1/4W	
R887	1-249-431-11	CARBON 15K 5% 1/4W	
R888	1-249-421-11	CARBON 2.2K 5% 1/4W	
R889	1-247-843-11	CARBON 3.3K 5% 1/4W	
R890	1-249-429-11	CARBON 10K 5% 1/4W	
△ R891	1-216-454-11	METAL OXIDE 390 5% 2W F	
R892	1-260-076-11	CARBON 10 5% 1/2W	
R893	1-260-076-11	CARBON 10 5% 1/2W	
R894	1-260-076-11	CARBON 10 5% 1/2W	
R895	1-260-076-11	CARBON 10 5% 1/2W	
△ R896	1-216-454-11	METAL OXIDE 390 5% 2W F	
		< RELAY >	
RY881	1-755-170-11	RELAY (12V)	
		< TERMINAL >	
TM881	1-537-238-31	TERMINAL BOARD (SPEAKER IMPEDANCE 6-16Ω)	

*	1-671-115-21	SW BOARD	

		< CONNECTOR >	
* CN601	1-506-486-11	PIN, CONNECTOR 7P	
		< SWITCH >	
S601	1-572-126-21	SWITCH, PUSH (1 KEY) (REC POSITION)	
S602	1-572-126-21	SWITCH, PUSH (1 KEY) (PACK OUT)	
S604	1-771-264-11	SWITCH, PUSH (DETECTION) (1 KEY) (PB POSITION)	

The components identified by mark △ or dotted line with mark △ are critical for safety. Replace only with part number specified.

HCD-F3MD

Ref. No.	Part No.	Description	Remark
		MISCELLANEOUS *****	
13	1-777-240-11	WIRE (FLAT TYPE) (21 CORE)	
14	1-791-211-11	WIRE (FLAT TYPE) (23 CORE)	
16	1-773-212-11	WIRE (FLAT TYPE) (25 CORE)	
17	1-792-756-11	WIRE (FLAT TYPE) (29 CORE)	
57	1-693-473-31	TUNER (FM/AM TUNER UNIT) (TW)	
57	1-693-473-41	TUNER (FM/AM TUNER UNIT) (HK, KR)	
59	1-773-115-11	WIRE (FLAT TYPE) (19 CORE)	
60	1-773-006-11	WIRE (FLAT TYPE) (15 CORE)	
61	1-569-972-21	SOCKET, SHORT 2P	
△62	1-769-079-21	CORD, POWER (KR)	
△62	1-769-744-11	CORD, POWER (HK, TW)	
* 158	1-667-954-11	PC BOARD, FLEXIBLE	
△160	A-4672-541-A	OPTICAL PICK-UP KMS-260B/S1NP	
△255	8-820-113-01	OPTICAL PICK-UP KSS-213BH/Z-NP	
256	1-782-817-11	WIRE (FLAT TYPE) (16 CORE)	
HR901	1-500-502-11	HEAD, OVER WRITE	
M101	X-4952-989-1	BASE (BU-5S) ASSY (CD)	
M102	X-4917-504-1	MOTOR ASSY (SLED) (CD)	
M103	A-4672-771-A	MOTOR (LD) ASSY (LOADING) (CD)	
M901	A-4672-475-A	MOTOR ASSY, SPINDLE (MD)	
M902	A-4672-474-A	MOTOR ASSY, SLED (MD)	
M903	X-4949-264-1	MOTOR ASSY, LOADING (MD)	
S102	1-762-148-21	SWITCH, PUSH (2 KEY) (PROTECT/REFLECT RATE DETECT)	
△T901	1-433-966-11	TRANSFORMER, POWER	

HARDWARE LIST			

#1	7-685-871-01	SCREW +BVTT 3X6 (S)	
#2	7-685-647-79	SCREW +BVTP 3X10 TYPE2 TT (B)	
#3	7-685-650-91	SCREW +BVTP 3X16 TYPE2 TT (B)	
#4	7-685-533-19	SCREW +BTP 2.6X6 TYPE2 N-S	
#5	7-627-852-08	SCREW, PRECISION +P 1.7X2.5	
#6	7-621-772-40	SCREW +B 2X8	
#7	7-621-772-20	SCREW +B 2X5	
#8	7-685-133-19	SCREW (DIA. 2.6) (IT3B)	
#12	7-621-772-10	SCREW +B 2X4	

ACCESSORIES & PACKING MATERIALS			

△	1-569-008-21	ADAPTOR, CONVERSION 2P (TW)	
△	1-770-019-11	ADAPTOR, CONVERSION PLUG 3P (HK)	

The components identified by mark △ or dotted line with mark △ are critical for safety. Replace only with part number specified.